



Manual transmission catalog
Catálogo de transmisiones manual
Catalogue de transmissions manuelle



Pro King Manual Transmissions

YEAR	ENGINE	APPLICATION	PART NO.	YEAR	ENGINE	APPLICATION	PART NO.
ACURA				BUICK (cont.)			
INTEGRA				SOMERSET			
4 CYL				4 CYL			
1996-01	1.8L	5 Spd, S80 Trans, REBUILDABLE CORE REQUIRED, REBUILD AND RETURN ONLY, Use 10W30	S80	1986-87	2.5L	5 Spd, MR8 Isuzu Style Trans, Aluminum Rear Cover Over 5th Gears, CORE REQUIRED, REBUILD AND RETURN ONLY, Use GM# 12345349 Fluid	MR8
BUICK				CADILLAC			
CENTURY				CIMARRON			
4 CYL				4 CYL			
1988	2.5L	5 Spd, MR10 Muncie Style Trans, Flat Metal Cover Over 5th Gears, CORE REQUIRED, REBUILD AND RETURN ONLY, Use GM# 12345349 Fluid	MR10	1983-86	2.0L	5 Spd, MR8 Isuzu Style Trans, Aluminum Rear Cover Over 5th Gears, CORE REQUIRED, REBUILD AND RETURN ONLY, Use GM# 12345349 Fluid	MR8
6 CYL				CHEVROLET			
1988	2.8L, 3.8L	5 Spd, MR10 Muncie Style Trans, Flat Metal Cover Over 5th Gears, CORE REQUIRED, REBUILD AND RETURN ONLY, Use GM# 12345349 Fluid	MR10	"C10, C1500 PICKUP & SUBURBAN"			
SKYHAWK				6 CYL			
4 CYL				1975-80	4.1L	4x2, 4 Spd, SM465 Trans, With Tail Housing Mount, Use 80W90	SM465-B
1983-89	1.8L, 2.0L	5 Spd, MR8 Isuzu Style Trans, Aluminum Rear Cover Over 5th Gears, CORE REQUIRED, REBUILD AND RETURN ONLY, Use GM# 12345349 Fluid	MR8	"C20, C2500 PICKUP & SUBURBAN"			
SKYLARK				6 CYL			
4 CYL				1981-82	4.8L	4 Spd, NP833 Trans (3 Spd w/OD), Iron Case Or Aluminum Case, 10 Bolt Side Cover, CORE REQUIRED, REBUILD AND RETURN ONLY, Use ATF	NP833O/D
1992-94	2.3L	5 Spd, MR8 Isuzu Style Trans, Aluminum Rear Cover Over 5th Gears, CORE REQUIRED, REBUILD AND RETURN ONLY, Use GM# 12345349 Fluid	MR8	1975-82	4.8L	4x2, 4 Spd, SM465 Trans, With Tail Housing Mount, Use 80W90	SM465-B
1986-89	2.3L, 2.5L	5 Spd, MR8 Isuzu Style Trans, Aluminum Rear Cover Over 5th Gears, CORE REQUIRED, REBUILD AND RETURN ONLY, Use GM# 12345349 Fluid	MR8	8 CYL			
6 CYL				1981-84	5.0L, 5.7L, 6.2L, 7.4L	4 Spd, NP833 Trans (3 Spd w/OD), Iron Case Or Aluminum Case, 10 Bolt Side Cover, CORE REQUIRED, REBUILD AND RETURN ONLY, Use ATF	NP833O/D
1992-94	3.1L, 3.3L	5 Spd, MR8 Isuzu Style Trans, Aluminum Rear Cover Over 5th Gears, CORE REQUIRED, REBUILD AND RETURN ONLY, Use GM# 12345349 Fluid	MR8	1975-84	5.0L, 5.7L, 6.2L, 6.6L, 7.4L	4x2, 4 Spd, SM465 Trans, With Tail Housing Mount, Use 80W90	SM465-B
1986-89	3.0L, 3.3L	5 Spd, MR8 Isuzu Style Trans, Aluminum Rear Cover Over 5th Gears, CORE REQUIRED, REBUILD AND RETURN ONLY, Use GM# 12345349 Fluid	MR8				

Pro King Manual Transmissions

YEAR	ENGINE	APPLICATION	PART NO.	YEAR	ENGINE	APPLICATION	PART NO.
CHEVROLET (cont.)				CHEVROLET (cont.)			
"K10, K1500 PICKUP & SUBURBAN"				"S10 BLAZER, PICKUP" (cont.)			
6 CYL				6 CYL (cont.)			
1975-80	4.1L	4x2, 4 Spd, SM465 Trans, 10 Spine Output Shaft, No Threaded Holes In Case, Use 80W90	SM465-E	1999-00	4.3L	4x2, 5 Spd, Getrag NV3500 Trans, Press in Speedo, GM# 1234539 Fluid Used, 15" Tail Housing, Alum. Case, Code GADT	290-E
8 CYL				1999-00	4.3L	4x4, 5 Spd, Getrag NV3500 Trans, CORE REQUIRED, REBUILD AND RETURN ONLY, No Speedo, GM# 1234539 Fluid Used, 14" Tail Housing, Code GADU	290-D
1981-84	5.0L, 5.7L, 6.2L	4 Spd, NP833 Trans (3 Spd w/OD), Iron Case Or Aluminum Case, 10 Bolt Side Cover, CORE REQUIRED, REBUILD AND RETURN ONLY, Use ATF	NP833O/D	1990-94	4.3L	4x2, 5 Spd, Getrag NV3500 Trans, Press in Electric Speedo, GM# 1234539 Fluid Used, 18.5" Tail Housing, Code GWF	290-G
1981-84	5.0L, 5.7L, 6.2L	4x4, 4 Spd, SM465 Trans, 32 Spine Output Shaft, , Use 80W90	SM465-F	1990-94	4.3L	4x4, 5 Spd, Getrag NV3500 Trans, No Speedo, GM# 1234539 Fluid Used, 13" Tail Housing, Code GWH	290-F
1975-84	5.0L, 5.7L, 6.2L, 6.6L	4x2, 4 Spd, SM465 Trans, 10 Spine Output Shaft, No Threaded Holes In Case, Use 80W90	SM465-E	1986-89	2.8L	4x4, 5 Spd, Borg Warner T5 Non WC, No Speedo, ATF Used	T5-CF
"K20, K2500 PICKUP & SUBURBAN"				1986-88	2.8L	4x2, 5 Spd, Borg Warner T5 Speedo- Red, ATF Used	T5-CG
6 CYL				1983-84	2.8L	4x2, 5 Spd, Borg Warner T5 Speedo- Red, ATF Used	T5-CG
1981-82	4.8L	4 Spd, NP833 Trans (3 Spd w/OD), Iron Case Or Aluminum Case, 10 Bolt Side Cover, CORE REQUIRED, REBUILD AND RETURN ONLY, Use ATF	NP833O/D	1983-84	2.8L	4x4, 5 Spd, Borg Warner T5 Non WC, No Speedo, ATF Used	T5-CF
1981-82	4.8L	4x4, 4 Spd, SM465 Trans, 32 Spine Output Shaft, , Use 80W90	SM465-F	BERETTA			
1975-82	4.8L	4x2, 4 Spd, SM465 Trans, 10 Spine Output Shaft, No Threaded Holes In Case, Use 80W90	SM465-E	4 CYL			
8 CYL				1987-96	2.0L, 2.2L, 2.3L	5 Spd, MR8 Isuzu Style Trans, Aluminum Rear Cover Over 5th Gears, CORE REQUIRED, REBUILD AND RETURN ONLY, Use GM# 12345349 Fluid	MR8
1981-84	5.7L, 6.2L	4 Spd, NP833 Trans (3 Spd w/OD), Iron Case Or Aluminum Case, 10 Bolt Side Cover, CORE REQUIRED, REBUILD AND RETURN ONLY, Use ATF	NP833O/D	1987-94	2.0L, 2.2L, 2.3L	5 Spd, MR10 Muncie Style Trans, Flat Metal Cover Over 5th Gears, CORE REQUIRED, REBUILD AND RETURN ONLY, Use GM# 12345349 Fluid	MR10
1981-84	5.7L, 6.2L	4x4, 4 Spd, SM465 Trans, 32 Spine Output Shaft, , Use 80W90	SM465-F	6 CYL			
1975-84	5.0L, 5.7L, 6.2L, 6.6L	4x2, 4 Spd, SM465 Trans, 10 Spine Output Shaft, No Threaded Holes In Case, Use 80W90	SM465-E	1987-96	2.8L, 3.1L	5 Spd, MR8 Isuzu Style Trans, Aluminum Rear Cover Over 5th Gears, CORE REQUIRED, REBUILD AND RETURN ONLY, Use GM# 12345349 Fluid	MR8
"S10 BLAZER, PICKUP"				1987-94	2.8L, 3.1L	5 Spd, MR10 Muncie Style Trans, Flat Metal Cover Over 5th Gears, CORE REQUIRED, REBUILD AND RETURN ONLY, Use GM# 12345349 Fluid	MR10
4 CYL				BLAZER			
1986-88	2.5L	4x2, 5 Spd, Borg Warner T5 Speedo- Red, ATF Used	T5-CG	6 CYL			
1986-88	2.5L	4x4, 5 Spd, Borg Warner T5 Non WC, No Speedo, ATF Used	T5-CF	2001-03	4.3L	4x2, 5 Spd, Getrag NV3500 Trans, Electric Speedo Screw in, GM# 1234539 Fluid Used, 18.5" Tail Housing, Alum. Case, Code GBDX	290-J
1983-84	1.9L, 2.0L	4x4, 5 Spd, Borg Warner T5 Non WC, No Speedo, ATF Used	T5-CF	BLAZER			
1983-84	1.9L, 2.0L, 2.2L	4x2, 5 Spd, Borg Warner T5 Speedo- Red, ATF Used	T5-CG	6 CYL			
6 CYL				2001	4.3L	4x2, 5 Spd, Getrag NV3500 Trans, Electric Speedo Screw in, GM# 1234539 Fluid Used, 18.5" Tail Housing, Alum. Case, Code GBDX	290-J

Pro King Manual Transmissions

YEAR	ENGINE	APPLICATION	PART NO.
CHEVROLET (cont.)			
BLAZER (cont.)			
6 CYL (cont.)			
1996-00	4.3L	4x2, 5 Spd, Getrag NV3500 Trans, Press in Speedo, GM# 1234539 Fluid Used, 15" Tail Housing, Alum. Case, Code GADT	290-E
1996-00	4.3L	4x4, 5 Spd, Getrag NV3500 Trans, CORE REQUIRED, REBUILD AND RETURN ONLY, No Speedo, GM# 1234539 Fluid Used, 14" Tail Housing, Code GADU	290-D
1995	4.3L	4x2, 5 Spd, Getrag NV3500 Trans, GM# 1234539 Fluid Used, REBUILDABLE CORE REQUIRED, REBUILD AND RETURN ONLY, FRONT CASE MUST BE IN GOOD CONDITION	290-C
1995	4.3L	4x4, 5 Spd, Getrag NV3500 Trans, No Speedo, GM# 1234539 Fluid Used, 14" Tail Housing Code GZA, REBUILDABLE CORE REQUIRED, REBUILD AND RETURN ONLY, FRONT CASE MUST BE IN GOOD CONDITION	290-AB
8 CYL			
1993-94	5.7L, 6.5L	4x2, 5 Spd, Getrag NV3500 Trans, GM# 1234539 Fluid Used, REBUILDABLE CORE REQUIRED, REBUILD AND RETURN ONLY, FRONT CASE MUST BE IN GOOD CONDITION	290-C
1993-94	5.7L, 6.5L	4x4, 5 Spd, Getrag NV3500 Trans, No Speedo, GM# 1234539 Fluid Used, 14" Tail Housing Code GZA, REBUILDABLE CORE REQUIRED, REBUILD AND RETURN ONLY, FRONT CASE MUST BE IN GOOD CONDITION	290-AB
1988-92	5.7L, 6.2L	4x2, 5 Spd, Getrag NV3500 Trans, GM# 1234539 Fluid Used	290-B
1988-92	5.7L, 6.2L	4x4, 5 Spd, Getrag NV3500 Trans, No Speedo, GM# 1234539 Fluid Used, 14" Tail Housing	290-A
1988-91	5.7L, 6.2L	4x2, 4 Spd, SM465 Trans, Aluminum Top Cover With Electric Speedo, Use GM# 12345577 Fluid	SM465-H
1988-91	5.7L, 6.2L	4x2, 4 Spd, SM465 Trans, Aluminum Top Cover With Mechanical Speedo, Use GM# 12345577 Fluid	SM465-G
1988-91	5.7L, 6.2L	4x4, 4 Spd, SM465 Trans, 32 Spine Output Shaft, Use GM# 12345577 Fluid	SM465-F
1988-91	5.7L, 6.2L	4x4, 4 Spd, SM465 Trans, Aluminum Top Cover, Use GM# 12345577 Fluid	SM465-I
1987-88	5.0L, 5.7L, 6.2L	4 Spd, NP833 Trans (3 Spd w/OD), Iron Case Or Aluminum Case, 10 Bolt Side Cover, CORE REQUIRED, REBUILD AND RETURN ONLY, Use ATF	NP833O/D

YEAR	ENGINE	APPLICATION	PART NO.
CHEVROLET (cont.)			
BLAZER (cont.)			
8 CYL (cont.)			
1987	5.0L, 5.7L, 6.2L	4x2, 4 Spd, SM465 Trans, 10 Spine Output Shaft, No Threaded Holes In Case, Use 80W90	SM465-E
1987	5.0L, 5.7L, 6.2L	4x2, 4 Spd, SM465 Trans, With Tail Housing Mount, Use 80W90	SM465-B
1987	5.0L, 5.7L, 6.2L	4x4, 4 Spd, SM465 Trans, 32 Spine Output Shaft, Use 80W90	SM465-F
C10			
6 CYL			
1986	4.3L	4 Spd, NP833 Trans (3 Spd w/OD), Iron Case Or Aluminum Case, 10 Bolt Side Cover, CORE REQUIRED, REBUILD AND RETURN ONLY, Use ATF	NP833O/D
1981-84	4.1L	4 Spd, NP833 Trans (3 Spd w/OD), Iron Case Or Aluminum Case, 10 Bolt Side Cover, CORE REQUIRED, REBUILD AND RETURN ONLY, Use ATF	NP833O/D
1975-86	4.1L, 4.3L, 4.8L	4x2, 4 Spd, SM465 Trans, With Tail Housing Mount, Use 80W90	SM465-B
8 CYL			
1986	5.0L, 5.7L, 6.2L	4 Spd, NP833 Trans (3 Spd w/OD), Iron Case Or Aluminum Case, 10 Bolt Side Cover, CORE REQUIRED, REBUILD AND RETURN ONLY, Use ATF	NP833O/D
1981-84	5.0L, 5.7L, 6.2L	4 Spd, NP833 Trans (3 Spd w/OD), Iron Case Or Aluminum Case, 10 Bolt Side Cover, CORE REQUIRED, REBUILD AND RETURN ONLY, Use ATF	NP833O/D
1975-86	5.0L, 5.7L, 6.2L, 6.6L, 7.4L	4x2, 4 Spd, SM465 Trans, With Tail Housing Mount, Use 80W90	SM465-B
C10 BIG TEN			
6 CYL			
1978-80	4.1L, 4.8L	4x2, 4 Spd, SM465 Trans, With Tail Housing Mount, Use 80W90	SM465-B
8 CYL			
1978-80	5.0L, 5.7L, 6.6L, 7.4L	4x2, 4 Spd, SM465 Trans, With Tail Housing Mount, Use 80W90	SM465-B
C1500			
6 CYL			
1997-98	4.3L	4x2, 5 Spd, NV4500 Trans, W/Speedo, Cast Iron Case, 6" Tail Housing, Flat Aluminum Front Retainer, Code GAMN, Use GM# 12346190 Fluid	NV4500-G
1997-98	4.3L	4x2, 5 Spd, NV4500 Trans, W/Speedo, Cast Iron Case, Flat Aluminum Front Retainer, 6" Tail Housing, Code GBBN, Use GM# 12346190 Fluid	NV4500-J

Pro King Manual Transmissions

YEAR	ENGINE	APPLICATION	PART NO.	YEAR	ENGINE	APPLICATION	PART NO.
CHEVROLET (cont.)				CHEVROLET (cont.)			
C1500 (cont.)				C1500 (cont.)			
6 CYL (cont.)				8 CYL (cont.)			
1996-98	4.3L	4x2, 5 Spd, Getrag NV3500 Trans, Press in Speedo, GM# 1234539 Fluid Used, 15" Tail Housing, Alum. Case, Code GADT	290-E	1993-95	6.2L, 6.5L	4x2, 5 Spd, NV4500 Trans, W/Speedo, Without Parking Brake, Code GAKH, Use GM# 12346190 Fluid	NV4500-D
1993-95	4.3L	4x2, 5 Spd, Getrag NV3500 Trans, GM# 1234539 Fluid Used, REBUILDABLE CORE REQUIRED, REBUILD AND RETURN ONLY, FRONT CASE MUST BE IN GOOD CONDITION	290-C	1988-92	5.0L, 5.7L, 6.2L, 7.4L	4x2, 5 Spd, Getrag NV3500 Trans, GM# 1234539 Fluid Used	290-B
1993-95	4.3L	4x2, 5 Spd, NV4500 Trans, W/Speedo, 6" Tail Housing, Cast Iron Case, Cast Iron Front Retainer, Code GAKF, Use GM# 12346190 Fluid	NV4500-C	1988-91	5.0L, 5.7L, 6.2L, 7.4L	4x2, 4 Spd, SM465 Trans, Aluminum Top Cover With Electric Speedo, Use GM# 12345577 Fluid	SM465-H
1993-95	4.3L	4x2, 5 Spd, NV4500 Trans, W/Speedo, With Parking Brake, Code GXW, Use GM# 12346190 Fluid	NV4500-I	1988-91	5.0L, 5.7L, 6.2L, 7.4L	4x2, 4 Spd, SM465 Trans, Aluminum Top Cover With Mechanical Speedo, Use GM# 12345577 Fluid	SM465-G
1988-92	4.3L	4x2, 5 Spd, Getrag NV3500 Trans, GM# 1234539 Fluid Used	290-B	1988-89	5.0L, 5.7L, 6.2L	4 Spd, NP833 Trans (3 Spd w/OD), Iron Case Or Aluminum Case, 10 Bolt Side Cover, CORE REQUIRED, REBUILD AND RETURN ONLY, Use ATF	NP833O/D
1988-91	4.3L	4x2, 4 Spd, SM465 Trans, Aluminum Top Cover With Electric Speedo, Use GM# 12345577 Fluid	SM465-H	C20			
1988-91	4.3L	4x2, 4 Spd, SM465 Trans, Aluminum Top Cover With Mechanical Speedo, Use GM# 12345577 Fluid	SM465-G	6 CYL			
1988-89	4.3L	4 Spd, NP833 Trans (3 Spd w/OD), Iron Case Or Aluminum Case, 10 Bolt Side Cover, CORE REQUIRED, REBUILD AND RETURN ONLY, Use ATF	NP833O/D	1986	4.3L, 4.8L	4 Spd, NP833 Trans (3 Spd w/OD), Iron Case Or Aluminum Case, 10 Bolt Side Cover, CORE REQUIRED, REBUILD AND RETURN ONLY, Use ATF	NP833O/D
8 CYL				1981-84	4.1L, 4.8L	4 Spd, NP833 Trans (3 Spd w/OD), Iron Case Or Aluminum Case, 10 Bolt Side Cover, CORE REQUIRED, REBUILD AND RETURN ONLY, Use ATF	NP833O/D
1997-98	5.0L, 5.7L	4x2, 5 Spd, NV4500 Trans, W/Speedo, Cast Iron Case, 6" Tail Housing, Flat Aluminum Front Retainer, Code GAMN, Use GM# 12346190 Fluid	NV4500-G	1975-86	4.1L, 4.3L, 4.8L	4x2, 4 Spd, SM465 Trans, With Tail Housing Mount, Use 80W90	SM465-B
1997-98	5.0L, 5.7L, 6.5L	4x2, 5 Spd, NV4500 Trans, W/Speedo, Cast Iron Case, Flat Aluminum Front Retainer, 6" Tail Housing, Code GBBN, Use GM# 12346190 Fluid	NV4500-J	8 CYL			
1996-98	5.0L, 5.7L, 6.5L	4x2, 5 Spd, Getrag NV3500 Trans, Press in Speedo, GM# 1234539 Fluid Used, 15" Tail Housing, Alum. Case, Code GADT	290-E	1986	5.0L, 5.7L, 6.2L, 7.4L	4 Spd, NP833 Trans (3 Spd w/OD), Iron Case Or Aluminum Case, 10 Bolt Side Cover, CORE REQUIRED, REBUILD AND RETURN ONLY, Use ATF	NP833O/D
1993-95	5.0L, 5.7L, 6.2L, 6.5L, 7.4L	4x2, 5 Spd, Getrag NV3500 Trans, GM# 1234539 Fluid Used, REBUILDABLE CORE REQUIRED, REBUILD AND RETURN ONLY, FRONT CASE MUST BE IN GOOD CONDITION	290-C	1981-84	5.0L, 5.7L, 6.2L, 7.4L	4 Spd, NP833 Trans (3 Spd w/OD), Iron Case Or Aluminum Case, 10 Bolt Side Cover, CORE REQUIRED, REBUILD AND RETURN ONLY, Use ATF	NP833O/D
1993-95	5.0L, 5.7L, 6.2L, 6.5L, 7.4L	4x2, 5 Spd, NV4500 Trans, W/Speedo, With Parking Brake, Code GXW, Use GM# 12346190 Fluid	NV4500-I	1975-86	5.0L, 5.7L, 6.2L, 6.6L, 7.4L	4x2, 4 Spd, SM465 Trans, With Tail Housing Mount, Use 80W90	SM465-B
1993-95	5.0L, 5.7L, 7.4L	4x2, 5 Spd, NV4500 Trans, W/Speedo, 6" Tail Housing, Cast Iron Case, Cast Iron Front Retainer, Code GAKF, Use GM# 12346190 Fluid	NV4500-C	C2500			
8 CYL				6 CYL			
1993-95	5.0L, 5.7L, 6.2L, 6.5L, 7.4L	4x2, 5 Spd, Getrag NV3500 Trans, GM# 1234539 Fluid Used, REBUILDABLE CORE REQUIRED, REBUILD AND RETURN ONLY, FRONT CASE MUST BE IN GOOD CONDITION	290-C	1993-95	4.3L	4x2, 5 Spd, Getrag NV3500 Trans, GM# 1234539 Fluid Used, REBUILDABLE CORE REQUIRED, REBUILD AND RETURN ONLY, FRONT CASE MUST BE IN GOOD CONDITION	290-C
1993-95	5.0L, 5.7L, 6.2L, 6.5L, 7.4L	4x2, 5 Spd, NV4500 Trans, W/Speedo, With Parking Brake, Code GXW, Use GM# 12346190 Fluid	NV4500-I	1993-95	4.3L	4x2, 5 Spd, NV4500 Trans, W/Speedo, 6" Tail Housing, Cast Iron Case, Cast Iron Front Retainer, Code GAKF, Use GM# 12346190 Fluid	NV4500-C
1993-95	5.0L, 5.7L, 7.4L	4x2, 5 Spd, NV4500 Trans, W/Speedo, 6" Tail Housing, Cast Iron Case, Cast Iron Front Retainer, Code GAKF, Use GM# 12346190 Fluid	NV4500-C				

Pro King Manual Transmissions

YEAR	ENGINE	APPLICATION	PART NO.	YEAR	ENGINE	APPLICATION	PART NO.
CHEVROLET (cont.)				CHEVROLET (cont.)			
C2500 (cont.)				C2500 (cont.)			
6 CYL (cont.)				8 CYL (cont.)			
1993-95	4.3L	4x2, 5 Spd, NV4500 Trans, W/Speedo, With Parking Brake, Code GXW, Use GM# 12346190 Fluid	NV4500-I	1988-89	5.0L, 5.7L, 6.2L	4 Spd, NP833 Trans (3 Spd w/OD), Iron Case Or Aluminum Case, 10 Bolt Side Cover, CORE REQUIRED, REBUILD AND RETURN ONLY, Use ATF	NP833O/D
1988-92	4.3L	4x2, 5 Spd, Getrag NV3500 Trans, GM# 1234539 Fluid Used	290-B	C30			
1988-91	4.3L	4x2, 4 Spd, SM465 Trans, Aluminum Top Cover With Electric Speedo, Use GM# 12345577 Fluid	SM465-H	6 CYL			
1988-91	4.3L	4x2, 4 Spd, SM465 Trans, Aluminum Top Cover With Mechanical Speedo, Use GM# 12345577 Fluid	SM465-G	1986	4.8L	4 Spd, NP833 Trans (3 Spd w/OD), Iron Case Or Aluminum Case, 10 Bolt Side Cover, CORE REQUIRED, REBUILD AND RETURN ONLY, Use ATF	NP833O/D
1988-89	4.3L	4 Spd, NP833 Trans (3 Spd w/OD), Iron Case Or Aluminum Case, 10 Bolt Side Cover, CORE REQUIRED, REBUILD AND RETURN ONLY, Use ATF	NP833O/D	1982-84	4.8L	4 Spd, NP833 Trans (3 Spd w/OD), Iron Case Or Aluminum Case, 10 Bolt Side Cover, CORE REQUIRED, REBUILD AND RETURN ONLY, Use ATF	NP833O/D
8 CYL				1975-86	4.1L, 4.8L	4x2, 4 Spd, SM465 Trans, With Tail Housing Mount, Use 80W90	SM465-B
1997-00	5.0L, 5.7L, 6.5L, 7.4L	4x2, 5 Spd, NV4500 Trans, W/Speedo, Cast Iron Case, Flat Aluminum Front Retainer, 6" Tail Housing, Code GBBN, Use GM# 12346190 Fluid	NV4500-J	8 CYL			
1997-00	5.0L, 5.7L, 7.4L	4x2, 5 Spd, NV4500 Trans, W/Speedo, Cast Iron Case, 6" Tail Housing, Flat Aluminum Front Retainer, Code GAMN, Use GM# 12346190 Fluid	NV4500-G	1986	5.0L, 5.7L, 6.2L, 7.4L	4 Spd, NP833 Trans (3 Spd w/OD), Iron Case Or Aluminum Case, 10 Bolt Side Cover, CORE REQUIRED, REBUILD AND RETURN ONLY, Use ATF	NP833O/D
1996-98	5.7L	4x2, 5 Spd, Getrag NV3500 Trans, Press in Speedo, GM# 1234539 Fluid Used, 15" Tail Housing, Alum. Case, Code GADT	290-E	1982-84	5.7L, 6.2L, 7.4L	4 Spd, NP833 Trans (3 Spd w/OD), Iron Case Or Aluminum Case, 10 Bolt Side Cover, CORE REQUIRED, REBUILD AND RETURN ONLY, Use ATF	NP833O/D
1993-95	5.0L, 5.7L, 6.2L, 6.5L, 7.4L	4x2, 5 Spd, Getrag NV3500 Trans, GM# 1234539 Fluid Used, REBUILDABLE CORE REQUIRED, REBUILD AND RETURN ONLY, FRONT CASE MUST BE IN GOOD CONDITION	290-C	1975-86	5.0L, 5.7L, 6.2L, 6.6L, 7.4L	4x2, 4 Spd, SM465 Trans, With Tail Housing Mount, Use 80W90	SM465-B
1993-95	5.0L, 5.7L, 6.2L, 6.5L, 7.4L	4x2, 5 Spd, NV4500 Trans, W/Speedo, With Parking Brake, Code GXW, Use GM# 12346190 Fluid	NV4500-I	C3500			
1993-95	5.0L, 5.7L, 7.4L	4x2, 5 Spd, NV4500 Trans, W/Speedo, 6" Tail Housing, Cast Iron Case, Cast Iron Front Retainer, Code GAKF, Use GM# 12346190 Fluid	NV4500-C	8 CYL			
1993-95	6.2L, 6.5L	4x2, 5 Spd, NV4500 Trans, W/Speedo, Without Parking Brake, Code GAKH, Use GM# 12346190 Fluid	NV4500-D	1996-00	5.7L, 6.5L, 7.4L	4x2, 5 Spd, NV4500 Trans, W/Speedo, Cast Iron Case, Flat Aluminum Front Retainer, 6" Tail Housing, Code GBBN, Use GM# 12346190 Fluid	NV4500-J
1988-92	5.0L, 5.7L, 6.2L, 6.5L, 7.4L	4x2, 5 Spd, Getrag NV3500 Trans, GM# 1234539 Fluid Used	290-B	1996-00	5.7L, 7.4L	4x2, 5 Spd, NV4500 Trans, W/Speedo, Cast Iron Case, 6" Tail Housing, Flat Aluminum Front Retainer, Code GAMN, Use GM# 12346190 Fluid	NV4500-G
1988-91	5.0L, 5.7L, 6.2L, 7.4L	4x2, 4 Spd, SM465 Trans, Aluminum Top Cover With Electric Speedo, Use GM# 12345577 Fluid	SM465-H	1992-95	5.7L, 6.2L, 6.5L, 7.4L	4x2, 5 Spd, NV4500 Trans, W/Speedo, With Parking Brake, Code GXW, Use GM# 12346190 Fluid	NV4500-I
1988-91	5.0L, 5.7L, 6.2L, 7.4L	4x2, 4 Spd, SM465 Trans, Aluminum Top Cover With Mechanical Speedo, Use GM# 12345577 Fluid	SM465-G	1992-95	5.7L, 7.4L	4x2, 5 Spd, NV4500 Trans, W/Speedo, 6" Tail Housing, Cast Iron Case, Cast Iron Front Retainer, Code GAKF, Use GM# 12346190 Fluid	NV4500-C
				1992-95	6.2L, 6.5L	4x2, 5 Spd, NV4500 Trans, W/Speedo, Without Parking Brake, Code GAKH, Use GM# 12346190 Fluid	NV4500-D
				1988-91	5.7L, 6.2L, 7.4L	4x2, 4 Spd, SM465 Trans, Aluminum Top Cover With Electric Speedo, Use GM# 12345577 Fluid	SM465-H

Pro King Manual Transmissions

YEAR	ENGINE	APPLICATION	PART NO.	YEAR	ENGINE	APPLICATION	PART NO.
CHEVROLET (cont.)				CHEVROLET (cont.)			
C3500 (cont.)				CAMARO (cont.)			
8 CYL (cont.)				6 CYL (cont.)			
1988-91	5.7L, 6.2L, 7.4L	4x2, 4 Spd, SM465 Trans, Aluminum Top Cover With Mechanical Speedo, Use GM# 12345577 Fluid	SM465-G	1976-80	3.8L, 4.1L	4 Spd, M21 Trans, CORE REQUIRED, REBUILD AND RETURN ONLY, 27 Spline Output Shaft, Close Ratio	M21-A
1988-91	5.7L, 6.2L, 7.4L	4x2, 5 Spd, Getrag NV3500 Trans, GM# 1234539 Fluid Used	290-B	1976-80	3.8L, 4.1L	4 Spd, M21 Trans, CORE REQUIRED, REBUILD AND RETURN ONLY, 32 Spline Output Shaft, Close Ratio	M21-B
1988-89	5.7L, 6.2L, 7.4L	4 Spd, NP833 Trans (3 Spd w/OD), Iron Case Or Aluminum Case, 10 Bolt Side Cover, CORE REQUIRED, REBUILD AND RETURN ONLY, Use ATF	NP833O/D	1975	4.1L	4 Spd, T10 Trans, 9 Bolt Side Cover, Super T10 Only, CORE REQUIRED, REBUILD AND RETURN ONLY, Use 80W90	T10W
C3500 HD				8 CYL			
8 CYL				6 CYL (cont.)			
2001	6.5L	4x2, 5 Spd, NV4500 Trans, CORE REQUIRED, REBUILD AND RETURN ONLY, Use GM# 12346190 Fluid	NV4500-HA	1997-02	5.7L	6 Spd, T56 Trans, CORE REQUIRED, REBUILD AND RETURN ONLY, Use ATF	T56-B
2001	6.5L, 8.1L	4x2, 5 Spd, NV4500 Trans, W/Speedo, Cast Iron Case, Flat Aluminum Front Retainer, 6" Tail Housing, Code GBBN, Use GM# 12346190 Fluid	NV4500-J	1993-96	5.7L	6 Spd, T56 Trans, CORE REQUIRED, REBUILD AND RETURN ONLY, Use ATF	T56-A
2001	8.1L	4x2, 5 Spd, NV4500 Trans, CORE REQUIRED, REBUILD AND RETURN ONLY, Use GM# 12346190 Fluid	NV4500-GA	1983-87	5.0L, 5.7L	5 Spd, Borg Warner T5, Speedo- Purple, ATF Used	T5-CC
C3500 HD CHASSIS CAB				6 CYL (cont.)			
8 CYL				8 CYL			
2002	6.5L	4x2, 5 Spd, NV4500 Trans, CORE REQUIRED, REBUILD AND RETURN ONLY, Use GM# 12346190 Fluid	NV4500-HA	1981-84	4.4L, 5.0L, 5.7L	4 Spd, T10 Trans, 9 Bolt Side Cover, Super T10 Only, CORE REQUIRED, REBUILD AND RETURN ONLY, Use 80W90	T10W
2002	6.5L, 8.1L	4x2, 5 Spd, NV4500 Trans, W/Speedo, Cast Iron Case, Flat Aluminum Front Retainer, 6" Tail Housing, Code GBBN, Use GM# 12346190 Fluid	NV4500-J	1976-80	4.4L, 5.0L, 5.7L	4 Spd, M21 Trans, CORE REQUIRED, REBUILD AND RETURN ONLY, 27 Spline Output Shaft, Close Ratio	M21-A
2002	8.1L	4x2, 5 Spd, NV4500 Trans, CORE REQUIRED, REBUILD AND RETURN ONLY, Use GM# 12346190 Fluid	NV4500-GA	1976-80	4.4L, 5.0L, 5.7L	4 Spd, M21 Trans, CORE REQUIRED, REBUILD AND RETURN ONLY, 32 Spline Output Shaft, Close Ratio	M21-B
CAMARO				CAVALIER			
4 CYL				4 CYL			
1982-84	2.5L	4 Spd, T10 Trans, 9 Bolt Side Cover, Super T10 Only, CORE REQUIRED, REBUILD AND RETURN ONLY, Use 80W90	T10W	1987-94	2.0L, 2.2L	5 Spd, MR10 Muncie Style Trans, Flat Metal Cover Over 5th Gears, CORE REQUIRED, REBUILD AND RETURN ONLY, Use GM# 12345349 Fluid	MR10
6 CYL				6 CYL			
1996-02	3.8L	5 Spd, T5 Trans, World Class, ATF Used	T5-CM	1983-02	2.0L, 2.2L, 2.3L, 2.4L	5 Spd, MR8 Isuzu Style Trans, Aluminum Rear Cover Over 5th Gears, CORE REQUIRED, REBUILD AND RETURN ONLY, Use GM# 12345349 Fluid	MR8
1993-96	3.4L, 3.8L	6 Spd, T56 Trans, CORE REQUIRED, REBUILD AND RETURN ONLY, Use ATF	T56-A	1987-94	2.8L, 3.1L	5 Spd, MR10 Muncie Style Trans, Flat Metal Cover Over 5th Gears, CORE REQUIRED, REBUILD AND RETURN ONLY, Use GM# 12345349 Fluid	MR10
1993-95	3.4L, 3.8L	5 Spd, Borg Warner T5, Speedo- Beige, ATF Used	T5-CL	1985-94	2.8L, 3.1L	5 Spd, MR8 Isuzu Style Trans, Aluminum Rear Cover Over 5th Gears, CORE REQUIRED, REBUILD AND RETURN ONLY, Use GM# 12345349 Fluid	MR8
1981-84	2.8L, 3.8L	4 Spd, T10 Trans, 9 Bolt Side Cover, Super T10 Only, CORE REQUIRED, REBUILD AND RETURN ONLY, Use 80W90	T10W				

Pro King Manual Transmissions

YEAR	ENGINE	APPLICATION	PART NO.	YEAR	ENGINE	APPLICATION	PART NO.
CHEVROLET (cont.)				CHEVROLET (cont.)			
CELEBRITY				CORSICA (cont.)			
4 CYL				6 CYL (cont.)			
1988-89	2.5L	5 Spd, MR10 Muncie Style Trans, Flat Metal Cover Over 5th Gears, CORE REQUIRED, REBUILD AND RETURN ONLY, Use GM# 12345349 Fluid	MR10	1987-94	2.8L, 3.1L	5 Spd, MR10 Muncie Style Trans, Flat Metal Cover Over 5th Gears, CORE REQUIRED, REBUILD AND RETURN ONLY, Use GM# 12345349 Fluid	MR10
6 CYL				CORVETTE			
1988-89	2.8L	5 Spd, MR10 Muncie Style Trans, Flat Metal Cover Over 5th Gears, CORE REQUIRED, REBUILD AND RETURN ONLY, Use GM# 12345349 Fluid	MR10	8 CYL			
CHEVETTE				1997-06	5.7L, 6.0L, 7.0L	6 Spd, T56 Trans, Rear Transaxle Type, Rear Differential NOT Included, REBUILDABLE CORE REQUIRED, REBUILD AND RETURN ONLY, Use ATF	T56-C
4 CYL				1990-95	5.7L	6 Spd, S6-40 Trans, LT5 And ZR1, CORE REQUIRED, REBUILD AND RETURN ONLY	S640-A
1982-87	1.6L, 1.8L	5 Spd, Borg Warner T5, CORE REQUIRED, REBUILD AND RETURN ONLY, Speedo- Natural, ATF Used	T5-CK	1989-96	5.7L	6 Spd, S6-40 Trans, L98, LT1 And LT4, CORE REQUIRED, REBUILD AND RETURN ONLY	S640
CITATION				1984-88	5.7L	4 Spd, T10 Trans, Used with Doug Nash Overdrive, REBUILDABLE CORE REQUIRED, REBUILD AND RETURN ONLY, Use 80W90	T10N
4 CYL				1981	5.7L	4 Spd, T10 Trans, Used with Doug Nash Overdrive, REBUILDABLE CORE REQUIRED, REBUILD AND RETURN ONLY, Use 80W90	T10N
1983	2.5L	4x4, 4 Spd, SM465 Trans, 32 Spine Output Shaft, , Use 80W90	SM465-F	EL CAMINO			
6 CYL				6 CYL			
1983	2.8L	4x4, 4 Spd, SM465 Trans, 32 Spine Output Shaft, , Use 80W90	SM465-F	1975	4.1L	4 Spd, T10 Trans, 9 Bolt Side Cover, Super T10 Only, CORE REQUIRED, REBUILD AND RETURN ONLY, Use 80W90	T10W
CITATION II				8 CYL			
4 CYL				1975	5.7L, 6.6L	4 Spd, T10 Trans, 9 Bolt Side Cover, Super T10 Only, CORE REQUIRED, REBUILD AND RETURN ONLY, Use 80W90	T10W
1984-85	2.5L	4x4, 4 Spd, SM465 Trans, 32 Spine Output Shaft, , Use 80W90	SM465-F	G10			
6 CYL				6 CYL			
1984-85	2.8L	4x4, 4 Spd, SM465 Trans, 32 Spine Output Shaft, , Use 80W90	SM465-F	1988-90	4.3L	4x2, 5 Spd, Getrag NV3500 Trans, GM# 1234539 Fluid Used	290-B
CORSICA				1988-90	4.3L	4x4, 5 Spd, Getrag NV3500 Trans, No Speedo, GM# 1234539 Fluid Used, 14" Tail Housing	290-A
4 CYL				1988-89	4.3L	4x2, 4 Spd, SM465 Trans, Aluminum Top Cover With Electric Speedo, Use GM# 12345577 Fluid	SM465-H
1987-96	2.0L, 2.2L	5 Spd, MR8 Isuzu Style Trans, Aluminum Rear Cover Over 5th Gears, CORE REQUIRED, REBUILD AND RETURN ONLY, Use GM# 12345349 Fluid	MR8	1988-89	4.3L	4x2, 4 Spd, SM465 Trans, Aluminum Top Cover With Mechanical Speedo, Use GM# 12345577 Fluid	SM465-G
1987-94	2.0L, 2.2L	5 Spd, MR10 Muncie Style Trans, Flat Metal Cover Over 5th Gears, CORE REQUIRED, REBUILD AND RETURN ONLY, Use GM# 12345349 Fluid	MR10	1988-89	4.3L	4x4, 4 Spd, SM465 Trans, 32 Spine Output Shaft, Use GM# 12345577 Fluid	SM465-F
6 CYL							
1987-96	2.8L, 3.1L	5 Spd, MR8 Isuzu Style Trans, Aluminum Rear Cover Over 5th Gears, CORE REQUIRED, REBUILD AND RETURN ONLY, Use GM# 12345349 Fluid	MR8				

Pro King Manual Transmissions

YEAR	ENGINE	APPLICATION	PART NO.	YEAR	ENGINE	APPLICATION	PART NO.
CHEVROLET (cont.)				CHEVROLET (cont.)			
G10 (cont.)				G10 (cont.)			
6 CYL (cont.)				8 CYL (cont.)			
1988-89	4.3L	4x4, 4 Spd, SM465 Trans, Aluminum Top Cover, Use GM# 12345577 Fluid	SM465-I	1985-87	5.0L	4x4, 4 Spd, SM465 Trans, 32 Spine Output Shaft, , Use 80W90	SM465-F
1986-89	4.3L	4 Spd, NP833 Trans (3 Spd w/OD), Iron Case Or Aluminum Case, 10 Bolt Side Cover, CORE REQUIRED, REBUILD AND RETURN ONLY, Use ATF	NP833O/D	1981-84	5.0L	4 Spd, NP833 Trans (3 Spd w/OD), Iron Case Or Aluminum Case, 10 Bolt Side Cover, CORE REQUIRED, REBUILD AND RETURN ONLY, Use ATF	NP833O/D
1985-87	4.3L	4x2, 4 Spd, SM465 Trans, 10 Spine Output Shaft, No Threaded Holes In Case, Use 80W90	SM465-E	1981-82	5.0L	4x4, 4 Spd, SM465 Trans, 32 Spine Output Shaft, , Use 80W90	SM465-F
1985-87	4.3L	4x2, 4 Spd, SM465 Trans, With Tail Housing Mount, Use 80W90	SM465-B	1975-82	5.0L, 5.7L	4x2, 4 Spd, SM465 Trans, 10 Spine Output Shaft, No Threaded Holes In Case, Use 80W90	SM465-E
1985-87	4.3L	4x4, 4 Spd, SM465 Trans, 32 Spine Output Shaft, , Use 80W90	SM465-F	1975-82	5.0L, 5.7L	4x2, 4 Spd, SM465 Trans, With Tail Housing Mount, Use 80W90	SM465-B
1981-84	4.1L	4 Spd, NP833 Trans (3 Spd w/OD), Iron Case Or Aluminum Case, 10 Bolt Side Cover, CORE REQUIRED, REBUILD AND RETURN ONLY, Use ATF	NP833O/D	G10 SPORTVAN			
1981-82	4.1L	4x4, 4 Spd, SM465 Trans, 32 Spine Output Shaft, , Use 80W90	SM465-F	6 CYL			
1975-82	4.1L	4x2, 4 Spd, SM465 Trans, 10 Spine Output Shaft, No Threaded Holes In Case, Use 80W90	SM465-E	1988-90	4.3L	4x2, 5 Spd, Getrag NV3500 Trans, GM# 1234539 Fluid Used	290-B
1975-82	4.1L	4x2, 4 Spd, SM465 Trans, With Tail Housing Mount, Use 80W90	SM465-B	1988-90	4.3L	4x4, 5 Spd, Getrag NV3500 Trans, No Speedo, GM# 1234539 Fluid Used, 14" Tail Housing	290-A
8 CYL				1988-89	4.3L	4x2, 4 Spd, SM465 Trans, Aluminum Top Cover With Electric Speedo, Use GM# 12345577 Fluid	SM465-H
1988-90	5.0L	4x2, 5 Spd, Getrag NV3500 Trans, GM# 1234539 Fluid Used	290-B	1988-89	4.3L	4x2, 4 Spd, SM465 Trans, Aluminum Top Cover With Mechanical Speedo, Use GM# 12345577 Fluid	SM465-G
1988-90	5.0L	4x4, 5 Spd, Getrag NV3500 Trans, No Speedo, GM# 1234539 Fluid Used, 14" Tail Housing	290-A	1988-89	4.3L	4x4, 4 Spd, SM465 Trans, Aluminum Top Cover, Use GM# 12345577 Fluid	SM465-F
1988-89	5.0L	4x2, 4 Spd, SM465 Trans, Aluminum Top Cover With Electric Speedo, Use GM# 12345577 Fluid	SM465-H	1986-89	4.3L	4 Spd, NP833 Trans (3 Spd w/OD), Iron Case Or Aluminum Case, 10 Bolt Side Cover, CORE REQUIRED, REBUILD AND RETURN ONLY, Use ATF	NP833O/D
1988-89	5.0L	4x2, 4 Spd, SM465 Trans, Aluminum Top Cover With Mechanical Speedo, Use GM# 12345577 Fluid	SM465-G	1985-87	4.3L	4x2, 4 Spd, SM465 Trans, 10 Spine Output Shaft, No Threaded Holes In Case, Use 80W90	SM465-E
1988-89	5.0L	4x4, 4 Spd, SM465 Trans, 32 Spine Output Shaft, Use GM# 12345577 Fluid	SM465-F	1985-87	4.3L	4x2, 4 Spd, SM465 Trans, With Tail Housing Mount, Use 80W90	SM465-B
1988-89	5.0L	4x4, 4 Spd, SM465 Trans, Aluminum Top Cover, Use GM# 12345577 Fluid	SM465-I	1985-87	4.3L	4x4, 4 Spd, SM465 Trans, 32 Spine Output Shaft, , Use 80W90	SM465-F
1986-89	5.0L	4 Spd, NP833 Trans (3 Spd w/OD), Iron Case Or Aluminum Case, 10 Bolt Side Cover, CORE REQUIRED, REBUILD AND RETURN ONLY, Use ATF	NP833O/D	1981-84	4.1L	4 Spd, NP833 Trans (3 Spd w/OD), Iron Case Or Aluminum Case, 10 Bolt Side Cover, CORE REQUIRED, REBUILD AND RETURN ONLY, Use ATF	NP833O/D
1985-87	5.0L	4x2, 4 Spd, SM465 Trans, 10 Spine Output Shaft, No Threaded Holes In Case, Use 80W90	SM465-E	1981-82	4.1L	4x4, 4 Spd, SM465 Trans, 32 Spine Output Shaft, , Use 80W90	SM465-F
1985-87	5.0L	4x2, 4 Spd, SM465 Trans, With Tail Housing Mount, Use 80W90	SM465-B	1975-82	4.1L	4x2, 4 Spd, SM465 Trans, 10 Spine Output Shaft, No Threaded Holes In Case, Use 80W90	SM465-E

Pro King Manual Transmissions

YEAR	ENGINE	APPLICATION	PART NO.	YEAR	ENGINE	APPLICATION	PART NO.
CHEVROLET (cont.)				CHEVROLET (cont.)			
G10 SPORTVAN (cont.)				G20 (cont.)			
6 CYL (cont.)				6 CYL (cont.)			
1975-82	4.1L	4x2, 4 Spd, SM465 Trans, With Tail Housing Mount, Use 80W90	SM465-B	1988-89	4.3L	4x2, 4 Spd, SM465 Trans, Aluminum Top Cover With Mechanical Speedo, Use GM# 12345577 Fluid	SM465-G
8 CYL				8 CYL			
1988-90	5.0L, 5.7L	4x2, 5 Spd, Getrag NV3500 Trans, GM# 1234539 Fluid Used	290-B	1988-89	4.3L	4x4, 4 Spd, SM465 Trans, 32 Spine Output Shaft, Use GM# 12345577 Fluid	SM465-F
1988-90	5.0L, 5.7L	4x4, 5 Spd, Getrag NV3500 Trans, No Speedo, GM# 1234539 Fluid Used, 14" Tail Housing	290-A	1988-89	4.3L	4x4, 4 Spd, SM465 Trans, Aluminum Top Cover, Use GM# 12345577 Fluid	SM465-I
1988-89	5.0L, 5.7L	4x2, 4 Spd, SM465 Trans, Aluminum Top Cover With Electric Speedo, Use GM# 12345577 Fluid	SM465-H	1986-89	4.3L	4 Spd, NP833 Trans (3 Spd w/OD), Iron Case Or Aluminum Case, 10 Bolt Side Cover, CORE REQUIRED, REBUILD AND RETURN ONLY, Use ATF	NP833O/D
1988-89	5.0L, 5.7L	4x2, 4 Spd, SM465 Trans, Aluminum Top Cover With Mechanical Speedo, Use GM# 12345577 Fluid	SM465-G	1985-87	4.3L	4x2, 4 Spd, SM465 Trans, 10 Spine Output Shaft, No Threaded Holes In Case, Use 80W90	SM465-E
1988-89	5.0L, 5.7L	4x4, 4 Spd, SM465 Trans, 32 Spine Output Shaft, Use GM# 12345577 Fluid	SM465-F	1985-87	4.3L	4x2, 4 Spd, SM465 Trans, With Tail Housing Mount, Use 80W90	SM465-B
1988-89	5.0L, 5.7L	4x4, 4 Spd, SM465 Trans, Aluminum Top Cover, Use GM# 12345577 Fluid	SM465-I	1985-87	4.3L	4x4, 4 Spd, SM465 Trans, 32 Spine Output Shaft, , Use 80W90	SM465-F
1986-89	5.0L, 5.7L	4 Spd, NP833 Trans (3 Spd w/OD), Iron Case Or Aluminum Case, 10 Bolt Side Cover, CORE REQUIRED, REBUILD AND RETURN ONLY, Use ATF	NP833O/D	1981-84	4.1L	4 Spd, NP833 Trans (3 Spd w/OD), Iron Case Or Aluminum Case, 10 Bolt Side Cover, CORE REQUIRED, REBUILD AND RETURN ONLY, Use ATF	NP833O/D
1985-87	5.0L, 5.7L	4x2, 4 Spd, SM465 Trans, 10 Spine Output Shaft, No Threaded Holes In Case, Use 80W90	SM465-E	1981-82	4.1L	4x4, 4 Spd, SM465 Trans, 32 Spine Output Shaft, , Use 80W90	SM465-F
1985-87	5.0L, 5.7L	4x2, 4 Spd, SM465 Trans, With Tail Housing Mount, Use 80W90	SM465-B	1975-82	4.1L, 4.8L	4x2, 4 Spd, SM465 Trans, 10 Spine Output Shaft, No Threaded Holes In Case, Use 80W90	SM465-E
1985-87	5.0L, 5.7L	4x4, 4 Spd, SM465 Trans, 32 Spine Output Shaft, , Use 80W90	SM465-F	1975-82	4.1L, 4.8L	4x2, 4 Spd, SM465 Trans, With Tail Housing Mount, Use 80W90	SM465-B
1981-84	5.0L, 5.7L	4 Spd, NP833 Trans (3 Spd w/OD), Iron Case Or Aluminum Case, 10 Bolt Side Cover, CORE REQUIRED, REBUILD AND RETURN ONLY, Use ATF	NP833O/D	8 CYL			
1981-82	5.0L, 5.7L	4x4, 4 Spd, SM465 Trans, 32 Spine Output Shaft, , Use 80W90	SM465-F	1988-90	5.0L, 5.7L, 6.2L	4x2, 5 Spd, Getrag NV3500 Trans, GM# 1234539 Fluid Used	290-B
1975-82	5.0L, 5.7L	4x2, 4 Spd, SM465 Trans, 10 Spine Output Shaft, No Threaded Holes In Case, Use 80W90	SM465-E	1988-90	5.0L, 5.7L, 6.2L	4x4, 5 Spd, Getrag NV3500 Trans, No Speedo, GM# 1234539 Fluid Used, 14" Tail Housing	290-A
1975-82	5.0L, 5.7L	4x2, 4 Spd, SM465 Trans, With Tail Housing Mount, Use 80W90	SM465-B	1988-89	5.0L, 5.7L, 6.2L	4x2, 4 Spd, SM465 Trans, Aluminum Top Cover With Electric Speedo, Use GM# 12345577 Fluid	SM465-H
G20				1988-89	5.0L, 5.7L, 6.2L	4x2, 4 Spd, SM465 Trans, Aluminum Top Cover With Mechanical Speedo, Use GM# 12345577 Fluid	SM465-G
6 CYL				1988-89	5.0L, 5.7L, 6.2L	4x4, 4 Spd, SM465 Trans, 32 Spine Output Shaft, Use GM# 12345577 Fluid	SM465-F
1988-90	4.3L	4x2, 5 Spd, Getrag NV3500 Trans, GM# 1234539 Fluid Used	290-B	1988-89	5.0L, 5.7L, 6.2L	4x4, 4 Spd, SM465 Trans, Aluminum Top Cover, Use GM# 12345577 Fluid	SM465-I
1988-90	4.3L	4x4, 5 Spd, Getrag NV3500 Trans, No Speedo, GM# 1234539 Fluid Used, 14" Tail Housing	290-A	1986-89	5.0L, 5.7L, 6.2L	4 Spd, NP833 Trans (3 Spd w/OD), Iron Case Or Aluminum Case, 10 Bolt Side Cover, CORE REQUIRED, REBUILD AND RETURN ONLY, Use ATF	NP833O/D
1988-89	4.3L	4x2, 4 Spd, SM465 Trans, Aluminum Top Cover With Electric Speedo, Use GM# 12345577 Fluid	SM465-H				

Pro King Manual Transmissions

YEAR	ENGINE	APPLICATION	PART NO.	YEAR	ENGINE	APPLICATION	PART NO.
CHEVROLET (cont.)				CHEVROLET (cont.)			
G20 (cont.)				G20 SPORTVAN (cont.)			
8 CYL (cont.)				6 CYL (cont.)			
1985-87	5.0L, 5.7L, 6.2L	4x2, 4 Spd, SM465 Trans, 10 Spine Output Shaft, No Threaded Holes In Case, Use 80W90	SM465-E	1981-82	4.1L	4x4, 4 Spd, SM465 Trans, 32 Spine Output Shaft, , Use 80W90	SM465-F
1985-87	5.0L, 5.7L, 6.2L	4x2, 4 Spd, SM465 Trans, With Tail Housing Mount, Use 80W90	SM465-B	1975-82	4.1L, 4.8L	4x2, 4 Spd, SM465 Trans, 10 Spine Output Shaft, No Threaded Holes In Case, Use 80W90	SM465-E
1985-87	5.0L, 5.7L, 6.2L	4x4, 4 Spd, SM465 Trans, 32 Spine Output Shaft, , Use 80W90	SM465-F	1975-82	4.1L, 4.8L	4x2, 4 Spd, SM465 Trans, With Tail Housing Mount, Use 80W90	SM465-B
1981-84	5.0L, 5.7L, 6.2L	4 Spd, NP833 Trans (3 Spd w/OD), Iron Case Or Aluminum Case, 10 Bolt Side Cover, CORE REQUIRED, REBUILD AND RETURN ONLY, Use ATF	NP833O/D	8 CYL			
1981-82	5.0L, 5.7L	4x4, 4 Spd, SM465 Trans, 32 Spine Output Shaft, , Use 80W90	SM465-F	1988-90	5.0L, 5.7L, 6.2L	4x2, 5 Spd, Getrag NV3500 Trans, GM# 1234539 Fluid Used	290-B
1975-82	5.0L, 5.7L, 6.6L, 7.4L	4x2, 4 Spd, SM465 Trans, 10 Spine Output Shaft, No Threaded Holes In Case, Use 80W90	SM465-E	1988-90	5.0L, 5.7L, 6.2L	4x4, 5 Spd, Getrag NV3500 Trans, No Speedo, GM# 1234539 Fluid Used, 14" Tail Housing	290-A
1975-82	5.0L, 5.7L, 6.6L, 7.4L	4x2, 4 Spd, SM465 Trans, With Tail Housing Mount, Use 80W90	SM465-B	1988-89	5.0L, 5.7L, 6.2L	4x2, 4 Spd, SM465 Trans, Aluminum Top Cover With Electric Speedo, Use GM# 12345577 Fluid	SM465-H
G20 SPORTVAN				1988-89	5.0L, 5.7L, 6.2L	4x2, 4 Spd, SM465 Trans, Aluminum Top Cover With Mechanical Speedo, Use GM# 12345577 Fluid	SM465-G
6 CYL				1988-89	5.0L, 5.7L, 6.2L	4x4, 4 Spd, SM465 Trans, 32 Spine Output Shaft, Use GM# 12345577 Fluid	SM465-F
1988-90	4.3L	4x2, 5 Spd, Getrag NV3500 Trans, GM# 1234539 Fluid Used	290-B	1988-89	5.0L, 5.7L, 6.2L	4x4, 4 Spd, SM465 Trans, Aluminum Top Cover, Use GM# 12345577 Fluid	SM465-I
1988-90	4.3L	4x4, 5 Spd, Getrag NV3500 Trans, No Speedo, GM# 1234539 Fluid Used, 14" Tail Housing	290-A	1986-89	5.0L, 5.7L, 6.2L	4 Spd, NP833 Trans (3 Spd w/OD), Iron Case Or Aluminum Case, 10 Bolt Side Cover, CORE REQUIRED, REBUILD AND RETURN ONLY, Use ATF	NP833O/D
1988-89	4.3L	4x2, 4 Spd, SM465 Trans, Aluminum Top Cover With Electric Speedo, Use GM# 12345577 Fluid	SM465-H	1985-87	5.0L, 5.7L, 6.2L	4x2, 4 Spd, SM465 Trans, 10 Spine Output Shaft, No Threaded Holes In Case, Use 80W90	SM465-E
1988-89	4.3L	4x2, 4 Spd, SM465 Trans, Aluminum Top Cover With Mechanical Speedo, Use GM# 12345577 Fluid	SM465-G	1985-87	5.0L, 5.7L, 6.2L	4x2, 4 Spd, SM465 Trans, With Tail Housing Mount, Use 80W90	SM465-B
1988-89	4.3L	4x4, 4 Spd, SM465 Trans, 32 Spine Output Shaft, Use GM# 12345577 Fluid	SM465-F	1985-87	5.0L, 5.7L, 6.2L	4x4, 4 Spd, SM465 Trans, 32 Spine Output Shaft, , Use 80W90	SM465-F
1988-89	4.3L	4x4, 4 Spd, SM465 Trans, Aluminum Top Cover, Use GM# 12345577 Fluid	SM465-I	1981-84	5.0L, 5.7L, 6.2L	4 Spd, NP833 Trans (3 Spd w/OD), Iron Case Or Aluminum Case, 10 Bolt Side Cover, CORE REQUIRED, REBUILD AND RETURN ONLY, Use ATF	NP833O/D
1986-89	4.3L	4 Spd, NP833 Trans (3 Spd w/OD), Iron Case Or Aluminum Case, 10 Bolt Side Cover, CORE REQUIRED, REBUILD AND RETURN ONLY, Use ATF	NP833O/D	1981-82	5.0L, 5.7L	4x4, 4 Spd, SM465 Trans, 32 Spine Output Shaft, , Use 80W90	SM465-F
1985-87	4.3L	4x2, 4 Spd, SM465 Trans, 10 Spine Output Shaft, No Threaded Holes In Case, Use 80W90	SM465-E	1975-82	5.0L, 5.7L, 6.6L	4x2, 4 Spd, SM465 Trans, 10 Spine Output Shaft, No Threaded Holes In Case, Use 80W90	SM465-E
1985-87	4.3L	4x2, 4 Spd, SM465 Trans, With Tail Housing Mount, Use 80W90	SM465-B	1975-82	5.0L, 5.7L, 6.6L	4x2, 4 Spd, SM465 Trans, With Tail Housing Mount, Use 80W90	SM465-B
1985-87	4.3L	4x4, 4 Spd, SM465 Trans, 32 Spine Output Shaft, , Use 80W90	SM465-F	G30			
1981-84	4.1L	4 Spd, NP833 Trans (3 Spd w/OD), Iron Case Or Aluminum Case, 10 Bolt Side Cover, CORE REQUIRED, REBUILD AND RETURN ONLY, Use ATF	NP833O/D	6 CYL			
				1988-90	4.3L	4x2, 5 Spd, Getrag NV3500 Trans, GM# 1234539 Fluid Used	290-B

Pro King Manual Transmissions

YEAR	ENGINE	APPLICATION	PART NO.	YEAR	ENGINE	APPLICATION	PART NO.
CHEVROLET (cont.)				CHEVROLET (cont.)			
G30 (cont.)				G30 SPORTVAN (cont.)			
6 CYL (cont.)				8 CYL (cont.)			
1988-90	4.3L	4x4, 5 Spd, Getrag NV3500 Trans, No Speedo, GM# 1234539 Fluid Used, 14" Tail Housing	290-A	1982-84	5.7L, 6.2L	4 Spd, NP833 Trans (3 Spd w/OD), Iron Case Or Aluminum Case, 10 Bolt Side Cover, CORE REQUIRED, REBUILD AND RETURN ONLY, Use ATF	NP833O/D
1982-84	4.1L	4 Spd, NP833 Trans (3 Spd w/OD), Iron Case Or Aluminum Case, 10 Bolt Side Cover, CORE REQUIRED, REBUILD AND RETURN ONLY, Use ATF	NP833O/D	1981-82	5.7L	4x4, 4 Spd, SM465 Trans, 32 Spine Output Shaft, , Use 80W90	SM465-F
1981-82	4.1L	4x2, 4 Spd, SM465 Trans, 10 Spine Output Shaft, No Threaded Holes In Case, Use 80W90	SM465-E	1975-82	5.7L, 6.6L	4x2, 4 Spd, SM465 Trans, 10 Spine Output Shaft, No Threaded Holes In Case, Use 80W90	SM465-E
1981-82	4.1L	4x2, 4 Spd, SM465 Trans, With Tail Housing Mount, Use 80W90	SM465-B	1975-82	5.7L, 6.6L	4x2, 4 Spd, SM465 Trans, With Tail Housing Mount, Use 80W90	SM465-B
1981-82	4.1L	4x4, 4 Spd, SM465 Trans, 32 Spine Output Shaft, , Use 80W90	SM465-F	K10			
1975-79	4.1L, 4.8L	4x2, 4 Spd, SM465 Trans, 10 Spine Output Shaft, No Threaded Holes In Case, Use 80W90	SM465-E	6 CYL			
1975-79	4.1L, 4.8L	4x2, 4 Spd, SM465 Trans, With Tail Housing Mount, Use 80W90	SM465-B	1986	4.3L	4 Spd, NP833 Trans (3 Spd w/OD), Iron Case Or Aluminum Case, 10 Bolt Side Cover, CORE REQUIRED, REBUILD AND RETURN ONLY, Use ATF	NP833O/D
8 CYL				1981-86	4.1L, 4.3L	4x4, 4 Spd, SM465 Trans, 32 Spine Output Shaft, , Use 80W90	SM465-F
1988-90	5.7L, 6.2L, 7.4L	4x2, 5 Spd, Getrag NV3500 Trans, GM# 1234539 Fluid Used	290-B	1981-84	4.1L	4 Spd, NP833 Trans (3 Spd w/OD), Iron Case Or Aluminum Case, 10 Bolt Side Cover, CORE REQUIRED, REBUILD AND RETURN ONLY, Use ATF	NP833O/D
1988-90	5.7L, 6.2L, 7.4L	4x4, 5 Spd, Getrag NV3500 Trans, No Speedo, GM# 1234539 Fluid Used, 14" Tail Housing	290-A	1975-86	4.1L, 4.3L, 4.8L	4x2, 4 Spd, SM465 Trans, 10 Spine Output Shaft, No Threaded Holes In Case, Use 80W90	SM465-E
1982-84	5.0L, 5.7L, 6.2L	4 Spd, NP833 Trans (3 Spd w/OD), Iron Case Or Aluminum Case, 10 Bolt Side Cover, CORE REQUIRED, REBUILD AND RETURN ONLY, Use ATF	NP833O/D	8 CYL			
1981-82	5.0L, 5.7L	4x4, 4 Spd, SM465 Trans, 32 Spine Output Shaft, , Use 80W90	SM465-F	1986	5.0L, 5.7L, 6.2L	4 Spd, NP833 Trans (3 Spd w/OD), Iron Case Or Aluminum Case, 10 Bolt Side Cover, CORE REQUIRED, REBUILD AND RETURN ONLY, Use ATF	NP833O/D
1975-82	5.0L, 5.7L, 6.6L, 7.4L	4x2, 4 Spd, SM465 Trans, 10 Spine Output Shaft, No Threaded Holes In Case, Use 80W90	SM465-E	1981-86	5.0L, 5.7L, 6.2L	4x4, 4 Spd, SM465 Trans, 32 Spine Output Shaft, , Use 80W90	SM465-F
1975-82	5.0L, 5.7L, 6.6L, 7.4L	4x2, 4 Spd, SM465 Trans, With Tail Housing Mount, Use 80W90	SM465-B	1981-84	5.0L, 5.7L, 6.2L	4 Spd, NP833 Trans (3 Spd w/OD), Iron Case Or Aluminum Case, 10 Bolt Side Cover, CORE REQUIRED, REBUILD AND RETURN ONLY, Use ATF	NP833O/D
G30 SPORTVAN				1975-86	5.0L, 5.7L, 6.2L, 6.6L, 7.4L	4x2, 4 Spd, SM465 Trans, 10 Spine Output Shaft, No Threaded Holes In Case, Use 80W90	SM465-E
6 CYL				K1500			
1975-78	4.8L	4x2, 4 Spd, SM465 Trans, 10 Spine Output Shaft, No Threaded Holes In Case, Use 80W90	SM465-E	6 CYL			
1975-78	4.8L	4x2, 4 Spd, SM465 Trans, With Tail Housing Mount, Use 80W90	SM465-B	1997-98	4.3L	4x4, 5 Spd, NV4500 Trans, No Speedo, Cast Iron Case, Flat Aluminum Front Retainer, Code GARH, Use GM# 12346190 Fluid	NV4500-E
8 CYL				1996-98	4.3L	4x4, 5 Spd, Getrag NV3500 Trans, CORE REQUIRED, REBUILD AND RETURN ONLY, No Speedo, GM# 1234539 Fluid Used, 14" Tail Housing, Code GADU	290-D
1988-90	5.7L, 6.2L, 7.4L	4x2, 5 Spd, Getrag NV3500 Trans, GM# 1234539 Fluid Used	290-B				
1988-90	5.7L, 6.2L, 7.4L	4x4, 5 Spd, Getrag NV3500 Trans, No Speedo, GM# 1234539 Fluid Used, 14" Tail Housing	290-A				

Pro King Manual Transmissions

YEAR	ENGINE	APPLICATION	PART NO.	YEAR	ENGINE	APPLICATION	PART NO.
CHEVROLET (cont.)				CHEVROLET (cont.)			
K1500 (cont.)				K1500 (cont.)			
6 CYL (cont.)				8 CYL (cont.)			
1993-95	4.3L	4x4, 5 Spd, Getrag NV3500 Trans, No Speedo, GM# 1234539 Fluid Used, 14" Tail Housing Code GZA, REBUILDABLE CORE REQUIRED, REBUILD AND RETURN ONLY, FRONT CASE MUST BE IN GOOD CONDITION	290-AB	1988-91	5.0L, 5.7L, 6.2L	4x4, 4 Spd, SM465 Trans, 32 Spine Output Shaft, Use GM# 12345577 Fluid	SM465-F
1993-95	4.3L	4x4, 5 Spd, NV4500 Trans, No Speedo, Cast Iron Case, Cast Iron Front Retainer, Code GAKD, Use GM# 12346190 Fluid	NV4500-A	1988-91	5.0L, 5.7L, 6.2L	4x4, 4 Spd, SM465 Trans, Aluminum Top Cover, Use GM# 12345577 Fluid	SM465-I
1988-92	4.3L	4x4, 5 Spd, Getrag NV3500 Trans, No Speedo, GM# 1234539 Fluid Used, 14" Tail Housing	290-A	1988-89	5.0L, 5.7L, 6.2L	4 Spd, NP833 Trans (3 Spd w/OD), Iron Case Or Aluminum Case, 10 Bolt Side Cover, CORE REQUIRED, REBUILD AND RETURN ONLY, Use ATF	NP833O/D
1988-91	4.3L	4x4, 4 Spd, SM465 Trans, 32 Spine Output Shaft, Use GM# 12345577 Fluid	SM465-F	K20			
1988-91	4.3L	4x4, 4 Spd, SM465 Trans, Aluminum Top Cover, Use GM# 12345577 Fluid	SM465-I	6 CYL			
1988-89	4.3L	4 Spd, NP833 Trans (3 Spd w/OD), Iron Case Or Aluminum Case, 10 Bolt Side Cover, CORE REQUIRED, REBUILD AND RETURN ONLY, Use ATF	NP833O/D	1986	4.8L	4 Spd, NP833 Trans (3 Spd w/OD), Iron Case Or Aluminum Case, 10 Bolt Side Cover, CORE REQUIRED, REBUILD AND RETURN ONLY, Use ATF	NP833O/D
8 CYL				1981-86	4.3L, 4.8L	4x4, 4 Spd, SM465 Trans, 32 Spine Output Shaft, , Use 80W90	SM465-F
1997-98	5.0L, 5.7L	4x4, 5 Spd, NV4500 Trans, No Speedo, Cast Iron Case, Flat Aluminum Front Retainer, Code GARH, Use GM# 12346190 Fluid	NV4500-E	1981-84	4.8L	4 Spd, NP833 Trans (3 Spd w/OD), Iron Case Or Aluminum Case, 10 Bolt Side Cover, CORE REQUIRED, REBUILD AND RETURN ONLY, Use ATF	NP833O/D
1997-98	6.5L	4x4, 5 Spd, NV4500 Trans, No Speedo, Cast Iron Case, Flat Aluminum Front Retainer, Code GAWN, Use GM# 12346190 Fluid	NV4500-F	1975-86	4.1L, 4.3L, 4.8L	4x2, 4 Spd, SM465 Trans, 10 Spine Output Shaft, No Threaded Holes In Case, Use 80W90	SM465-E
1996-98	5.0L, 5.7L, 6.5L	4x4, 5 Spd, Getrag NV3500 Trans, CORE REQUIRED, REBUILD AND RETURN ONLY, No Speedo, GM# 1234539 Fluid Used, 14" Tail Housing, Code GADU	290-D	8 CYL			
1993-95	5.0L, 5.7L	4x4, 5 Spd, NV4500 Trans, No Speedo, Cast Iron Case, Cast Iron Front Retainer, Code GAKD, Use GM# 12346190 Fluid	NV4500-A	1986	5.7L, 6.2L	4 Spd, NP833 Trans (3 Spd w/OD), Iron Case Or Aluminum Case, 10 Bolt Side Cover, CORE REQUIRED, REBUILD AND RETURN ONLY, Use ATF	NP833O/D
1993-95	5.0L, 5.7L, 6.2L, 6.5L	4x4, 5 Spd, Getrag NV3500 Trans, No Speedo, GM# 1234539 Fluid Used, 14" Tail Housing Code GZA, REBUILDABLE CORE REQUIRED, REBUILD AND RETURN ONLY, FRONT CASE MUST BE IN GOOD CONDITION	290-AB	1981-86	5.0L, 5.7L, 6.2L	4x4, 4 Spd, SM465 Trans, 32 Spine Output Shaft, , Use 80W90	SM465-F
1993-95	6.2L, 6.5L	4x4, 5 Spd, NV4500 Trans, No Speedo, Cast Iron Case, Cast Iron Front Retainer, Code GAKK, Use GM# 12346190 Fluid	NV4500-B	1981-84	5.7L, 6.2L	4 Spd, NP833 Trans (3 Spd w/OD), Iron Case Or Aluminum Case, 10 Bolt Side Cover, CORE REQUIRED, REBUILD AND RETURN ONLY, Use ATF	NP833O/D
1988-92	5.0L, 5.7L, 6.2L	4x4, 5 Spd, Getrag NV3500 Trans, No Speedo, GM# 1234539 Fluid Used, 14" Tail Housing	290-A	1975-86	5.0L, 5.7L, 6.2L, 6.6L, 7.4L	4x2, 4 Spd, SM465 Trans, 10 Spine Output Shaft, No Threaded Holes In Case, Use 80W90	SM465-E
K2500				6 CYL			
1993-95	4.3L	4x4, 5 Spd, Getrag NV3500 Trans, No Speedo, GM# 1234539 Fluid Used, 14" Tail Housing Code GZA, REBUILDABLE CORE REQUIRED, REBUILD AND RETURN ONLY, FRONT CASE MUST BE IN GOOD CONDITION	290-AB	1993-95	4.3L	4x4, 5 Spd, NV4500 Trans, No Speedo, Cast Iron Case, Cast Iron Front Retainer, Code GAKD, Use GM# 12346190 Fluid	NV4500-A

Pro King Manual Transmissions

YEAR	ENGINE	APPLICATION	PART NO.	YEAR	ENGINE	APPLICATION	PART NO.
CHEVROLET (cont.)				CHEVROLET (cont.)			
K2500 (cont.)				K30			
6 CYL (cont.)				6 CYL			
1988-92	4.3L	4x4, 5 Spd, Getrag NV3500 Trans, No Speedo, GM# 1234539 Fluid Used, 14" Tail Housing	290-A	1986	4.8L	4 Spd, NP833 Trans (3 Spd w/OD), Iron Case Or Aluminum Case, 10 Bolt Side Cover, CORE REQUIRED, REBUILD AND RETURN ONLY, Use ATF	NP8330/D
1988-91	4.3L	4x4, 4 Spd, SM465 Trans, 32 Spine Output Shaft, Use GM# 12345577 Fluid	SM465-F	1982-84	4.8L	4 Spd, NP833 Trans (3 Spd w/OD), Iron Case Or Aluminum Case, 10 Bolt Side Cover, CORE REQUIRED, REBUILD AND RETURN ONLY, Use ATF	NP8330/D
1988-91	4.3L	4x4, 4 Spd, SM465 Trans, Aluminum Top Cover, Use GM# 12345577 Fluid	SM465-I	1981-86	4.8L	4x4, 4 Spd, SM465 Trans, 32 Spine Output Shaft, , Use 80W90	SM465-F
1988-89	4.3L	4 Spd, NP833 Trans (3 Spd w/OD), Iron Case Or Aluminum Case, 10 Bolt Side Cover, CORE REQUIRED, REBUILD AND RETURN ONLY, Use ATF	NP8330/D	1977-86	4.8L	4x2, 4 Spd, SM465 Trans, 10 Spine Output Shaft, No Threaded Holes In Case, Use 80W90	SM465-E
8 CYL				8 CYL			
1997-00	5.0L, 5.7L, 7.4L	4x4, 5 Spd, NV4500 Trans, No Speedo, Cast Iron Case, Flat Aluminum Front Retainer, Code GARH, Use GM# 12346190 Fluid	NV4500-E	1986	5.7L, 6.2L, 7.4L	4 Spd, NP833 Trans (3 Spd w/OD), Iron Case Or Aluminum Case, 10 Bolt Side Cover, CORE REQUIRED, REBUILD AND RETURN ONLY, Use ATF	NP8330/D
1997-00	6.5L	4x4, 5 Spd, NV4500 Trans, No Speedo, Cast Iron Case, Flat Aluminum Front Retainer, Code GAWN, Use GM# 12346190 Fluid	NV4500-F	1982-84	5.7L, 6.2L, 7.4L	4 Spd, NP833 Trans (3 Spd w/OD), Iron Case Or Aluminum Case, 10 Bolt Side Cover, CORE REQUIRED, REBUILD AND RETURN ONLY, Use ATF	NP8330/D
1996-98	5.7L	4x4, 5 Spd, Getrag NV3500 Trans, CORE REQUIRED, REBUILD AND RETURN ONLY, No Speedo, GM# 1234539 Fluid Used, 14" Tail Housing, Code GADU	290-D	1981-86	5.7L, 6.2L, 7.4L	4x4, 4 Spd, SM465 Trans, 32 Spine Output Shaft, , Use 80W90	SM465-F
1993-95	5.0L, 5.7L, 6.2L, 6.5L, 7.4L	4x4, 5 Spd, Getrag NV3500 Trans, No Speedo, GM# 1234539 Fluid Used, 14" Tail Housing Code GZA, REBUILDABLE CORE REQUIRED, REBUILD AND RETURN ONLY, FRONT CASE MUST BE IN GOOD CONDITION	290-AB	1977-86	5.7L, 6.2L, 6.6L, 7.4L	4x2, 4 Spd, SM465 Trans, 10 Spine Output Shaft, No Threaded Holes In Case, Use 80W90	SM465-E
1993-95	5.0L, 5.7L, 7.4L	4x4, 5 Spd, NV4500 Trans, No Speedo, Cast Iron Case, Cast Iron Front Retainer, Code GAKD, Use GM# 12346190 Fluid	NV4500-A	K3500			
1993-95	6.2L, 6.5L	4x4, 5 Spd, NV4500 Trans, No Speedo, Cast Iron Case, Cast Iron Front Retainer, Code GAKK, Use GM# 12346190 Fluid	NV4500-B	8 CYL			
1988-92	5.0L, 5.7L, 6.2L, 6.5L, 7.4L	4x4, 5 Spd, Getrag NV3500 Trans, No Speedo, GM# 1234539 Fluid Used, 14" Tail Housing	290-A	1996-00	5.7L, 7.4L	4x4, 5 Spd, NV4500 Trans, No Speedo, Cast Iron Case, Flat Aluminum Front Retainer, Code GARH, Use GM# 12346190 Fluid	NV4500-E
1988-91	5.0L, 5.7L, 6.2L, 7.4L	4x4, 4 Spd, SM465 Trans, 32 Spine Output Shaft, Use GM# 12345577 Fluid	SM465-F	1996-00	6.5L	4x4, 5 Spd, NV4500 Trans, No Speedo, Cast Iron Case, Flat Aluminum Front Retainer, Code GAWN, Use GM# 12346190 Fluid	NV4500-F
1988-91	5.0L, 5.7L, 6.2L, 7.4L	4x4, 4 Spd, SM465 Trans, Aluminum Top Cover, Use GM# 12345577 Fluid	SM465-I	1992-95	5.7L, 7.4L	4x4, 5 Spd, NV4500 Trans, No Speedo, Cast Iron Case, Cast Iron Front Retainer, Code GAKD, Use GM# 12346190 Fluid	NV4500-A
1988-89	5.0L, 5.7L, 6.2L	4 Spd, NP833 Trans (3 Spd w/OD), Iron Case Or Aluminum Case, 10 Bolt Side Cover, CORE REQUIRED, REBUILD AND RETURN ONLY, Use ATF	NP8330/D	1992-95	6.2L, 6.5L	4x4, 5 Spd, NV4500 Trans, No Speedo, Cast Iron Case, Cast Iron Front Retainer, Code GAKK, Use GM# 12346190 Fluid	NV4500-B
				1988-91	5.7L, 6.2L, 7.4L	4x4, 4 Spd, SM465 Trans, 32 Spine Output Shaft, Use GM# 12345577 Fluid	SM465-F
				1988-91	5.7L, 6.2L, 7.4L	4x4, 4 Spd, SM465 Trans, Aluminum Top Cover, Use GM# 12345577 Fluid	SM465-I
				1988-91	5.7L, 6.2L, 7.4L	4x4, 5 Spd, Getrag NV3500 Trans, No Speedo, GM# 1234539 Fluid Used, 14" Tail Housing	290-A

Pro King Manual Transmissions

YEAR	ENGINE	APPLICATION	PART NO.	YEAR	ENGINE	APPLICATION	PART NO.
CHEVROLET (cont.)				CHEVROLET (cont.)			
K3500 (cont.)				P20 (cont.)			
8 CYL (cont.)				6 CYL (cont.)			
1988-89	5.7L, 6.2L, 7.4L	4 Spd, NP833 Trans (3 Spd w/OD), Iron Case Or Aluminum Case, 10 Bolt Side Cover, CORE REQUIRED, REBUILD AND RETURN ONLY, Use ATF	NP833O/D	1988-89	4.8L	4x2, 4 Spd, SM465 Trans, Aluminum Top Cover With Mechanical Speedo, Use GM# 12345577 Fluid	SM465-G
K5 BLAZER				1975-87	4.8L	4x2, 4 Spd, SM465 Trans, With Tail Housing Mount, Use 80W90	SM465-B
6 CYL				8 CYL			
1981-82	4.1L	4 Spd, NP833 Trans (3 Spd w/OD), Iron Case Or Aluminum Case, 10 Bolt Side Cover, CORE REQUIRED, REBUILD AND RETURN ONLY, Use ATF	NP833O/D	1988-89	5.7L, 6.2L	4x2, 4 Spd, SM465 Trans, Aluminum Top Cover With Electric Speedo, Use GM# 12345577 Fluid	SM465-H
1981-82	4.1L	4x4, 4 Spd, SM465 Trans, 32 Spine Output Shaft, , Use 80W90	SM465-F	1988-89	5.7L, 6.2L	4x2, 4 Spd, SM465 Trans, Aluminum Top Cover With Mechanical Speedo, Use GM# 12345577 Fluid	SM465-G
1975-82	4.1L	4x2, 4 Spd, SM465 Trans, 10 Spine Output Shaft, No Threaded Holes In Case, Use 80W90	SM465-E	1975-87	5.7L, 6.2L, 7.4L	4x2, 4 Spd, SM465 Trans, With Tail Housing Mount, Use 80W90	SM465-B
1975-82	4.1L	4x2, 4 Spd, SM465 Trans, With Tail Housing Mount, Use 80W90	SM465-B	P30			
8 CYL				4 CYL			
1986	5.0L, 5.7L, 6.2L	4 Spd, NP833 Trans (3 Spd w/OD), Iron Case Or Aluminum Case, 10 Bolt Side Cover, CORE REQUIRED, REBUILD AND RETURN ONLY, Use ATF	NP833O/D	1991	3.9L	4x2, 5 Spd, NV4500 Trans, With Out Park Brake, CORE REQUIRED, REBUILD AND RETURN ONLY, Use GM# 12346190 Fluid	NV4500-IA
1981-86	5.0L, 5.7L, 6.2L	4x4, 4 Spd, SM465 Trans, 32 Spine Output Shaft, , Use 80W90	SM465-F	1991	3.9L	4x2, 5 Spd, NV4500 Trans, With Park Brake, REBUILDABLE CORE REQUIRED, REBUILD AND RETURN ONLY, Use GM# 12346190 Fluid	NV4500-IB
1981-84	5.0L, 5.7L, 6.2L	4 Spd, NP833 Trans (3 Spd w/OD), Iron Case Or Aluminum Case, 10 Bolt Side Cover, CORE REQUIRED, REBUILD AND RETURN ONLY, Use ATF	NP833O/D	1989-90	3.9L	4x2, 4 Spd, SM465 Trans, Aluminum Top Cover With Electric Speedo, Use GM# 12345577 Fluid	SM465-H
1975-86	5.0L, 5.7L, 6.2L, 6.6L, 7.4L	4x2, 4 Spd, SM465 Trans, 10 Spine Output Shaft, No Threaded Holes In Case, Use 80W90	SM465-E	1989-90	3.9L	4x2, 4 Spd, SM465 Trans, Aluminum Top Cover With Mechanical Speedo, Use GM# 12345577 Fluid	SM465-G
1975-86	5.0L, 5.7L, 6.2L, 6.6L, 7.4L	4x2, 4 Spd, SM465 Trans, With Tail Housing Mount, Use 80W90	SM465-B	6 CYL			
P10				1996-99	4.3L	4x2, 5 Spd, NV4500 Trans, With Out Park Brake, CORE REQUIRED, REBUILD AND RETURN ONLY, Use GM# 12346190 Fluid	NV4500-JA
6 CYL				1996-99	4.3L	4x2, 5 Spd, NV4500 Trans, With Park Brake, CORE REQUIRED, REBUILD AND RETURN ONLY, Use GM# 12346190 Fluid	NV4500-JB
1975-80	4.8L	4x2, 4 Spd, SM465 Trans, With Tail Housing Mount, Use 80W90	SM465-B	1991-95	4.3L	4x2, 5 Spd, NV4500 Trans, With Out Park Brake, CORE REQUIRED, REBUILD AND RETURN ONLY, Use GM# 12346190 Fluid	NV4500-IA
8 CYL				1991-95	4.3L	4x2, 5 Spd, NV4500 Trans, With Park Brake, REBUILDABLE CORE REQUIRED, REBUILD AND RETURN ONLY, Use GM# 12346190 Fluid	NV4500-IB
1977-79	5.0L, 5.7L, 6.6L	4x2, 4 Spd, SM465 Trans, With Tail Housing Mount, Use 80W90	SM465-B	1988-90	4.3L, 4.8L	4x2, 4 Spd, SM465 Trans, Aluminum Top Cover With Electric Speedo, Use GM# 12345577 Fluid	SM465-H
1975	5.7L	4x2, 4 Spd, SM465 Trans, With Tail Housing Mount, Use 80W90	SM465-B	1988-90	4.3L, 4.8L	4x2, 4 Spd, SM465 Trans, Aluminum Top Cover With Mechanical Speedo, Use GM# 12345577 Fluid	SM465-G
P20				6 CYL			
6 CYL				1988-89	4.8L	4x2, 4 Spd, SM465 Trans, Aluminum Top Cover With Electric Speedo, Use GM# 12345577 Fluid	SM465-H

Pro King Manual Transmissions

YEAR	ENGINE	APPLICATION	PART NO.	YEAR	ENGINE	APPLICATION	PART NO.
CHEVROLET (cont.)				CHEVROLET (cont.)			
P30 (cont.)				R20			
6 CYL (cont.)				6 CYL			
1975-87	4.1L, 4.8L	4x2, 4 Spd, SM465 Trans, With Tail Housing Mount, Use 80W90	SM465-B	1988	4.8L	4x2, 4 Spd, SM465 Trans, Aluminum Top Cover With Electric Speedo, Use GM# 12345577 Fluid	SM465-H
8 CYL				8 CYL			
1996-99	5.7L, 6.5L, 7.4L	4x2, 5 Spd, NV4500 Trans, With Out Park Brake, CORE REQUIRED, REBUILD AND RETURN ONLY, Use GM# 12346190 Fluid	NV4500-JA	1988	4.8L	4x2, 4 Spd, SM465 Trans, Aluminum Top Cover With Mechanical Speedo, Use GM# 12345577 Fluid	SM465-G
1996-99	5.7L, 6.5L, 7.4L	4x2, 5 Spd, NV4500 Trans, With Park Brake, CORE REQUIRED, REBUILD AND RETURN ONLY, Use GM# 12346190 Fluid	NV4500-JB	1988	4.8L	4x2, 5 Spd, Getrag NV3500 Trans, GM# 1234539 Fluid Used	290-B
1991-95	5.7L, 6.2L, 6.5L, 7.4L	4x2, 5 Spd, NV4500 Trans, With Out Park Brake, CORE REQUIRED, REBUILD AND RETURN ONLY, Use GM# 12346190 Fluid	NV4500-IA	1987-88	4.3L, 4.8L	4 Spd, NP833 Trans (3 Spd w/OD), Iron Case Or Aluminum Case, 10 Bolt Side Cover, CORE REQUIRED, REBUILD AND RETURN ONLY, Use ATF	NP833O/D
1991-95	5.7L, 6.2L, 6.5L, 7.4L	4x2, 5 Spd, NV4500 Trans, With Park Brake, REBUILDABLE CORE REQUIRED, REBUILD AND RETURN ONLY, Use GM# 12346190 Fluid	NV4500-IB	1987	4.3L, 4.8L	4x2, 4 Spd, SM465 Trans, With Tail Housing Mount, Use 80W90	SM465-B
1988-90	5.7L, 6.2L, 7.4L	4x2, 4 Spd, SM465 Trans, Aluminum Top Cover With Electric Speedo, Use GM# 12345577 Fluid	SM465-H	8 CYL			
1988-90	5.7L, 6.2L, 7.4L	4x2, 4 Spd, SM465 Trans, Aluminum Top Cover With Mechanical Speedo, Use GM# 12345577 Fluid	SM465-G	1988	5.7L, 6.2L, 7.4L	4x2, 4 Spd, SM465 Trans, Aluminum Top Cover With Electric Speedo, Use GM# 12345577 Fluid	SM465-H
1975-87	5.7L, 6.2L, 6.6L, 7.4L	4x2, 4 Spd, SM465 Trans, With Tail Housing Mount, Use 80W90	SM465-B	1988	5.7L, 6.2L, 7.4L	4x2, 4 Spd, SM465 Trans, Aluminum Top Cover With Mechanical Speedo, Use GM# 12345577 Fluid	SM465-G
PRIZM				R2500			
4 CYL				8 CYL			
1998-02	1.8L	5 Spd, C51 Trans, CORE REQUIRED, REBUILD AND RETURN ONLY, Use SYNTHETIC 75W90	C51	1987	5.0L, 5.7L, 6.2L, 7.4L	4x2, 5 Spd, Getrag NV3500 Trans, GM# 1234539 Fluid Used	290-B
R10				R30			
6 CYL				6 CYL			
1987	4.3L	4 Spd, NP833 Trans (3 Spd w/OD), Iron Case Or Aluminum Case, 10 Bolt Side Cover, CORE REQUIRED, REBUILD AND RETURN ONLY, Use ATF	NP833O/D	1988	4.8L	4x2, 4 Spd, SM465 Trans, Aluminum Top Cover With Electric Speedo, Use GM# 12345577 Fluid	SM465-H
1987	4.3L	4x2, 4 Spd, SM465 Trans, With Tail Housing Mount, Use 80W90	SM465-B	1988	4.8L	4x2, 4 Spd, SM465 Trans, Aluminum Top Cover With Mechanical Speedo, Use GM# 12345577 Fluid	SM465-G
8 CYL				8 CYL			
1987	5.0L, 5.7L, 6.2L	4 Spd, NP833 Trans (3 Spd w/OD), Iron Case Or Aluminum Case, 10 Bolt Side Cover, CORE REQUIRED, REBUILD AND RETURN ONLY, Use ATF	NP833O/D	1987-88	4.8L	4 Spd, NP833 Trans (3 Spd w/OD), Iron Case Or Aluminum Case, 10 Bolt Side Cover, CORE REQUIRED, REBUILD AND RETURN ONLY, Use ATF	NP833O/D
1987	5.0L, 5.7L, 6.2L	4x2, 4 Spd, SM465 Trans, With Tail Housing Mount, Use 80W90	SM465-B	8 CYL			

Pro King Manual Transmissions

YEAR	ENGINE	APPLICATION	PART NO.	YEAR	ENGINE	APPLICATION	PART NO.
CHEVROLET (cont.)				CHEVROLET (cont.)			
R30 (cont.)				S10 (cont.)			
6 CYL (cont.)				6 CYL (cont.)			
1987	4.8L	4x2, 4 Spd, SM465 Trans, With Tail Housing Mount, Use 80W90	SM465-B	1996-98	4.3L	4x2, 5 Spd, Getrag NV3500 Trans, Press in Speedo, GM# 1234539 Fluid Used, 18.5" Tail Housing, Code GADP	290-I
8 CYL				8 CYL			
1988	5.7L, 6.2L, 7.4L	4x2, 4 Spd, SM465 Trans, Aluminum Top Cover With Electric Speedo, Use GM# 12345577 Fluid	SM465-H	1996-98	4.3L	4x4, 5 Spd, Getrag NV3500 Trans, No Speedo, GM# 1234539 Fluid Used, 13" Tail Housing Code, GADR	290-H
1988	5.7L, 6.2L, 7.4L	4x2, 4 Spd, SM465 Trans, Aluminum Top Cover With Mechanical Speedo, Use GM# 12345577 Fluid	SM465-G	1990-95	4.3L	GADS, Aluminum Case 4x2, 5 Spd, Getrag NV3500 Trans, Press in Electric Speedo, GM# 1234539 Fluid Used, 18.5" Tail Housing, Code GWF	290-G
1987-88	5.7L, 6.2L, 7.4L	4 Spd, NP833 Trans (3 Spd w/OD), Iron Case Or Aluminum Case, 10 Bolt Side Cover, CORE REQUIRED, REBUILD AND RETURN ONLY, Use ATF	NP833O/D	1990-95	4.3L	4x4, 5 Spd, Getrag NV3500 Trans, No Speedo, GM# 1234539 Fluid Used, 13" Tail Housing, Code GWH	290-F
1987	5.7L, 6.2L, 7.4L	4x2, 4 Spd, SM465 Trans, With Tail Housing Mount, Use 80W90	SM465-B	1986-89	2.8L	4x4, 5 Spd, Borg Warner T5 Non WC, No Speedo, ATF Used	T5-CF
R3500				SILVERADO 1500			
8 CYL				6 CYL			
1989-91	5.7L, 6.2L, 7.4L	4x2, 4 Spd, SM465 Trans, Aluminum Top Cover With Electric Speedo, Use GM# 12345577 Fluid	SM465-H	1999-00	4.3L	4x2, 5 Spd, Getrag NV3500 Trans, Press in Speedo, GM# 1234539 Fluid Used, 15" Tail Housing, Alum. Case, Code GADT	290-E
1989-91	5.7L, 6.2L, 7.4L	4x2, 4 Spd, SM465 Trans, Aluminum Top Cover With Mechanical Speedo, Use GM# 12345577 Fluid	SM465-G	1999-00	4.3L	4x4, 5 Spd, Getrag NV3500 Trans, CORE REQUIRED, REBUILD AND RETURN ONLY, No Speedo, GM# 1234539 Fluid Used, 14" Tail Housing, Code GADU	290-D
S10				8 CYL			
4 CYL				8 CYL			
1999-03	2.2L	4x2, 5 Spd, NV1500 Trans, With Screw In Speedo, CORE REQUIRED, REBUILD AND RETURN ONLY, Use GM# 12377916 Fluid	NV1500-B	1999-04	4.8L	4x4, 5 Spd, Getrag NV3500 Trans, No Speedo, GM# 1234539 Fluid Used, 14" Tail Housing, Code GBKT	290-M
1996-99	2.2L	4x2, 5 Spd, NV1500 Trans, With Press In Speedo, Use GM# 12377916 Fluid	NV1500-A	1999-04	5.3L, 6.0L	4x2, 5 Spd, Getrag NV3500 Trans, Electric Speedo Screw in, GM# 1234539 Fluid Used, 18.5" Tail Housing, Alum. Case, Code GBDX	290-J
1994-95	2.2L	4x2, 5 Spd, Borg Warner T5 WC, Electric Speedo, ATF Used, 26 Spline Input Shaft	T5-CJ	SILVERADO 2500			
1994-95	2.2L	4x4, 5 Spd, Borg Warner T5 Non WC, No Speedo, ATF Used	T5-CF	8 CYL			
1986-89	2.5L	4x4, 5 Spd, Borg Warner T5 Non WC, No Speedo, ATF Used	T5-CF	2001-05	6.0L, 8.1L	4x2, 5 Spd, NV4500 Trans, CORE REQUIRED, REBUILD AND RETURN ONLY, Use GM# 12346190 Fluid	NV4500-GA
1986-88	2.5L	4x2, 5 Spd, Borg Warner T5 Speedo- Red, ATF Used	T5-CG	2001-05	6.0L, 8.1L	4x4, 5 Spd, NV4500 Trans, With Out Vibration Damper, CORE REQUIRED, REBUILD AND RETURN ONLY, Use GM# 12346190 Fluid	NV4500-EA
1982-84	1.9L, 2.0L	4x4, 5 Spd, Borg Warner T5 Non WC, No Speedo, ATF Used	T5-CF	6 CYL			
1982-84	1.9L, 2.0L, 2.2L	4x2, 5 Spd, Borg Warner T5 Speedo- Red, ATF Used	T5-CG	6 CYL			
2000-03	4.3L	4x2, 5 Spd, Getrag NV3500 Trans, Screw in Electric Speedo, GM# 1234539 Fluid Used, 18.5" Tail Housing, Shifter to Tail Housing, Code GBKW	290-K	6 CYL			
1999-03	4.3L	4x4, 5 Spd, Getrag NV3500 Trans, GM# 1234539 Fluid Used	290-L	6 CYL			

Pro King Manual Transmissions

YEAR	ENGINE	APPLICATION	PART NO.	YEAR	ENGINE	APPLICATION	PART NO.
CHEVROLET (cont.)				CHEVROLET (cont.)			
SILVERADO 2500 (cont.)				TAHOE (cont.)			
8 CYL (cont.)				8 CYL (cont.)			
2001-05	6.6L	4x2, 5 Spd, NV4500 Trans, CORE REQUIRED, REBUILD AND RETURN ONLY, Use GM# 12346190 Fluid	NV4500-HA	1996	5.7L	4x4, 5 Spd, Getrag NV3500 Trans, CORE REQUIRED, REBUILD AND RETURN ONLY, No Speedo, GM# 1234539 Fluid Used, 14" Tail Housing, Code GADU	290-D
2001-05	6.6L	4x4, 5 Spd, NV4500 Trans, CORE REQUIRED, REBUILD AND RETURN ONLY, Use GM# 12346190 Fluid	NV4500-FA	1996	5.7L	4x4, 5 Spd, NV4500 Trans, No Speedo, Cast Iron Case, Flat Aluminum Front Retainer, Code GARH, Use GM# 12346190 Fluid	NV4500-E
1999-00	5.3L, 6.0L	4x2, 5 Spd, NV4500 Trans, W/Speedo, Cast Iron Case, 6" Tail Housing, Flat Aluminum Front Retainer, Code GAMN, Use GM# 12346190 Fluid	NV4500-G	1996	6.5L	4x2, 5 Spd, NV4500 Trans, W/Speedo, Cast Iron Case With Brake, Flat Aluminum Front Retainer, Code GARF, Use GM# 12346190 Fluid	NV4500-H
1999-00	5.3L, 6.0L	4x4, 5 Spd, NV4500 Trans, No Speedo, Cast Iron Case, Flat Aluminum Front Retainer, Code GARH, Use GM# 12346190 Fluid	NV4500-E	1996	6.5L	4x4, 5 Spd, NV4500 Trans, No Speedo, Cast Iron Case, Flat Aluminum Front Retainer, Code GAWN, Use GM# 12346190 Fluid	NV4500-F
SILVERADO 3500				1995	5.7L	4x2, 5 Spd, NV4500 Trans, W/Speedo, 6" Tail Housing, Cast Iron Case, Cast Iron Front Retainer, Code GAKF, Use GM# 12346190 Fluid	NV4500-C
8 CYL				1995	5.7L	4x4, 5 Spd, NV4500 Trans, No Speedo, Cast Iron Case, Cast Iron Front Retainer, Code GAKD, Use GM# 12346190 Fluid	NV4500-A
2001-05	6.0L, 8.1L	4x2, 5 Spd, NV4500 Trans, CORE REQUIRED, REBUILD AND RETURN ONLY, Use GM# 12346190 Fluid	NV4500-GA	1995	5.7L, 6.5L	4x2, 5 Spd, Getrag NV3500 Trans, GM# 1234539 Fluid Used, REBUILDABLE CORE REQUIRED, REBUILD AND RETURN ONLY, FRONT CASE MUST BE IN GOOD CONDITION	290-C
2001-05	6.0L, 8.1L	4x4, 5 Spd, NV4500 Trans, With Out Vibration Damper, CORE REQUIRED, REBUILD AND RETURN ONLY, Use GM# 12346190 Fluid	NV4500-EA	1995	5.7L, 6.5L	4x4, 5 Spd, Getrag NV3500 Trans, No Speedo, GM# 1234539 Fluid Used, 14" Tail Housing Code GZA, REBUILDABLE CORE REQUIRED, REBUILD AND RETURN ONLY, FRONT CASE MUST BE IN GOOD CONDITION	290-AB
2001-05	6.6L	4x2, 5 Spd, NV4500 Trans, CORE REQUIRED, REBUILD AND RETURN ONLY, Use GM# 12346190 Fluid	NV4500-HA	1995	6.5L	4x2, 5 Spd, NV4500 Trans, W/Speedo, Without Parking Brake, Code GAKH, Use GM# 12346190 Fluid	NV4500-D
2001-05	6.6L	4x4, 5 Spd, NV4500 Trans, CORE REQUIRED, REBUILD AND RETURN ONLY, Use GM# 12346190 Fluid	NV4500-FA	1995	6.5L	4x4, 5 Spd, NV4500 Trans, No Speedo, Cast Iron Case, Cast Iron Front Retainer, Code GAKK, Use GM# 12346190 Fluid	NV4500-B
SPECTRUM				TRACKER			
4 CYL				4 CYL			
1985-88	1.5L	5 Spd, MR8 Isuzu Style Trans, Aluminum Rear Cover Over 5th Gears, CORE REQUIRED, REBUILD AND RETURN ONLY, Use GM# 12345349 Fluid	MR8	1998	1.6L	4x2, 5 Spd, TRACKER Trans, Use 75W90	SIDE-A
TAHOE				1998	1.6L	4x4, 5 Spd, TRACKER Trans, Use 75W90	SIDE-B
8 CYL				6 CYL			
1996	5.7L	4x2, 5 Spd, Getrag NV3500 Trans, Press in Speedo, GM# 1234539 Fluid Used, 15" Tail Housing, Alum. Case, Code GADT	290-E	2001-04	2.5L	5 Spd, MR8 Isuzu Style Trans, Aluminum Rear Cover Over 5th Gears, CORE REQUIRED, REBUILD AND RETURN ONLY, Use GM# 12345349 Fluid	MR8
1996	5.7L	4x2, 5 Spd, NV4500 Trans, W/Speedo, Cast Iron Case, 6" Tail Housing, Flat Aluminum Front Retainer, Code GAMN, Use GM# 12346190 Fluid	NV4500-G				

Pro King Manual Transmissions

YEAR	ENGINE	APPLICATION	PART NO.	YEAR	ENGINE	APPLICATION	PART NO.
CHEVROLET (cont.)				CHEVROLET (cont.)			
V10				V30 (cont.)			
6 CYL				6 CYL (cont.)			
1987	4.3L	4 Spd, NP833 Trans (3 Spd w/OD), Iron Case Or Aluminum Case, 10 Bolt Side Cover, CORE	NP833O/D	1988	4.8L	4x4, 4 Spd, SM465 Trans, Aluminum Top Cover, Use GM# 12345577 Fluid	SM465-I
		REQUIRED, REBUILD AND RETURN ONLY, Use ATF		1987-88	4.8L	4 Spd, NP833 Trans (3 Spd w/OD), Iron Case Or Aluminum Case, 10 Bolt Side Cover, CORE	NP833O/D
1987	4.3L	4x2, 4 Spd, SM465 Trans, 10 Spine Output Shaft, No Threaded Holes In Case, Use 80W90	SM465-E			REQUIRED, REBUILD AND RETURN ONLY, Use ATF	
1987	4.3L	4x4, 4 Spd, SM465 Trans, 32 Spine Output Shaft, , Use 80W90	SM465-F	1987	4.8L	4x2, 4 Spd, SM465 Trans, 10 Spine Output Shaft, No Threaded Holes In Case, Use 80W90	SM465-E
8 CYL				8 CYL			
1987	5.0L, 5.7L, 6.2L	4 Spd, NP833 Trans (3 Spd w/OD), Iron Case Or Aluminum Case, 10 Bolt Side Cover, CORE	NP833O/D	1988	5.7L, 6.2L, 7.4L	4x2, 4 Spd, SM465 Trans, Aluminum Top Cover With Electric Speedo, Use GM# 12345577 Fluid	SM465-H
		REQUIRED, REBUILD AND RETURN ONLY, Use ATF		1988	5.7L, 6.2L, 7.4L	4x2, 4 Spd, SM465 Trans, Aluminum Top Cover With Mechanical Speedo, Use GM# 12345577 Fluid	SM465-G
1987	5.0L, 5.7L, 6.2L	4x2, 4 Spd, SM465 Trans, 10 Spine Output Shaft, No Threaded Holes In Case, Use 80W90	SM465-E	1988	5.7L, 6.2L, 7.4L	4x4, 4 Spd, SM465 Trans, 32 Spine Output Shaft, Use GM# 12345577 Fluid	SM465-F
1987	5.0L, 5.7L, 6.2L	4x4, 4 Spd, SM465 Trans, 32 Spine Output Shaft, , Use 80W90	SM465-F	1988	5.7L, 6.2L, 7.4L	4x4, 4 Spd, SM465 Trans, Aluminum Top Cover, Use GM# 12345577 Fluid	SM465-I
V20				V3500			
6 CYL				8 CYL			
1987	4.8L	4 Spd, NP833 Trans (3 Spd w/OD), Iron Case Or Aluminum Case, 10 Bolt Side Cover, CORE	NP833O/D	1989-91	5.7L, 6.2L, 7.4L	4x2, 4 Spd, SM465 Trans, Aluminum Top Cover With Electric Speedo, Use GM# 12345577 Fluid	SM465-H
		REQUIRED, REBUILD AND RETURN ONLY, Use ATF		1989-91	5.7L, 6.2L, 7.4L	4x2, 4 Spd, SM465 Trans, Aluminum Top Cover With Mechanical Speedo, Use GM# 12345577 Fluid	SM465-G
1987	4.8L	4x2, 4 Spd, SM465 Trans, 10 Spine Output Shaft, No Threaded Holes In Case, Use 80W90	SM465-E	1989-91	5.7L, 6.2L, 7.4L	4x4, 4 Spd, SM465 Trans, 32 Spine Output Shaft, Use GM# 12345577 Fluid	SM465-F
1987	4.8L	4x4, 4 Spd, SM465 Trans, 32 Spine Output Shaft, , Use 80W90	SM465-F	1989-91	5.7L, 6.2L, 7.4L	4x4, 4 Spd, SM465 Trans, Aluminum Top Cover, Use GM# 12345577 Fluid	SM465-I
8 CYL				8 CYL			
1987	5.7L, 6.2L	4 Spd, NP833 Trans (3 Spd w/OD), Iron Case Or Aluminum Case, 10 Bolt Side Cover, CORE	NP833O/D			REQUIRED, REBUILD AND RETURN ONLY, Use ATF	
		REQUIRED, REBUILD AND RETURN ONLY, Use ATF		1987	5.7L, 6.2L, 7.4L	4x2, 4 Spd, SM465 Trans, 10 Spine Output Shaft, No Threaded Holes In Case, Use 80W90	SM465-E
1987	5.7L, 6.2L	4x2, 4 Spd, SM465 Trans, 10 Spine Output Shaft, No Threaded Holes In Case, Use 80W90	SM465-E	1987	5.7L, 6.2L, 7.4L	4x4, 4 Spd, SM465 Trans, 32 Spine Output Shaft, , Use 80W90	SM465-F
1987	5.7L, 6.2L	4x4, 4 Spd, SM465 Trans, 32 Spine Output Shaft, , Use 80W90	SM465-F	CHRYSLER			
V30				SEBRING			
6 CYL				4 CYL			
1988	4.8L	4x2, 4 Spd, SM465 Trans, Aluminum Top Cover With Electric Speedo, Use GM# 12345577 Fluid	SM465-H	1995-98	2.0L	5 Spd, All Aluminum Case, Cable Operated Clutch, Use MOPAR# 4874465 Fluid	A578-A
1988	4.8L	4x2, 4 Spd, SM465 Trans, Aluminum Top Cover With Mechanical Speedo, Use GM# 12345577 Fluid	SM465-G				
1988	4.8L	4x4, 4 Spd, SM465 Trans, 32 Spine Output Shaft, Use GM# 12345577 Fluid	SM465-F				

Pro King Manual Transmissions

YEAR	ENGINE	APPLICATION	PART NO.	YEAR	ENGINE	APPLICATION	PART NO.
CHRYSLER (cont.)				DODGE (cont.)			
SEBRING (cont.)				COLT (cont.)			
4 CYL (cont.)				4 CYL (cont.)			
1995-98	2.0L	5 Spd, All Aluminum Case, Hydraulic Operated Clutch, Use MOPAR# 4874465 Fluid	A578-B	1989	1.6L	5 Spd, KM210 Trans, 7 Bolt Cover Over 5th Gears, CORE REQUIRED, REBUILD AND RETURN ONLY, Use 75W90	KM210
6 CYL				6 CYL			
1995-98	2.5L	5 Spd, All Aluminum Case, Cable Operated Clutch, Use MOPAR# 4874465 Fluid	A578-A	1987-89	1.5L	4 Spd, KM200 Trans, CORE REQUIRED, REBUILD AND RETURN ONLY, Use 75W90	KM200
1995-98	2.5L	5 Spd, All Aluminum Case, Hydraulic Operated Clutch, Use MOPAR# 4874465 Fluid	A578-B	1987-89	1.5L	5 Spd, KM201 Trans, CORE REQUIRED, REBUILD AND RETURN ONLY, Use 75W90	KM201
DODGE				D100			
ASPEN				6 CYL			
6 CYL				8 CYL			
1976-79	3.7L	4 Spd, NP833 Trans (3 Spd w/OD), Iron Case Or Aluminum Case, 10 Bolt Side Cover, CORE REQUIRED, REBUILD AND RETURN ONLY, Use ATF	NP833O/D	1986-89	3.7L, 3.9L	4x2, 5 Spd, Getrag 360, Press-In Speedo, 5W30 Used, Iron Case	G360-A
8 CYL				8 CYL			
1976-79	5.2L, 5.9L	4 Spd, NP833 Trans (3 Spd w/OD), Iron Case Or Aluminum Case, 10 Bolt Side Cover, CORE REQUIRED, REBUILD AND RETURN ONLY, Use ATF	NP833O/D	1975-79	3.7L, 4.0L	4x2, 4 Spd, NP435 Trans, Aluminum Tail Housing, Use 50WT Fluid	NP435-G
AVENGER				8 CYL			
4 CYL				8 CYL			
1995-98	2.0L	5 Spd, All Aluminum Case, Cable Operated Clutch, Use MOPAR# 4874465 Fluid	A578-A	1986-89	5.2L, 5.9L	4x2, 5 Spd, Getrag 360, Press-In Speedo, 5W30 Used, Iron Case	G360-A
1995-98	2.0L	5 Spd, All Aluminum Case, Hydraulic Operated Clutch, Use MOPAR# 4874465 Fluid	A578-B	1975-79	5.2L, 5.9L, 6.6L, 7.2L	4x2, 4 Spd, NP435 Trans, Aluminum Tail Housing, Use 50WT Fluid	NP435-G
6 CYL				8 CYL			
1997-98	2.5L	5 Spd, All Aluminum Case, Cable Operated Clutch, Use MOPAR# 4874465 Fluid	A578-A	1975-79	5.2L, 5.9L, 6.6L, 7.2L	4x2, 4 Spd, NP435 Trans, Cast Iron Tail Housing, Use 50WT Fluid	NP435-F
1997-98	2.5L	5 Spd, All Aluminum Case, Hydraulic Operated Clutch, Use MOPAR# 4874465 Fluid	A578-B	D150			
COLT				6 CYL			
4 CYL				8 CYL			
1993-94	1.8L, 2.4L	5 Spd, F5M22 Trans, CORE REQUIRED, REBUILD AND RETURN ONLY, Use 75W90	F5M22	1990-93	3.9L	4x2, 5 Spd, Getrag 360, Press-In Speedo, 5W30 Used, Iron Case	G360-A
1990-94	1.5L	5 Spd, F5M21 Trans, CORE REQUIRED, REBUILD AND RETURN ONLY, Use 75W90	F5M21	1981-89	3.7L, 3.9L	4x2, 4 Spd, NP435 Trans, Aluminum Tail Housing, Use 50WT Fluid	NP435-G
1990-92	1.5L	4 Spd, F4M21 Trans, CORE REQUIRED, REBUILD AND RETURN ONLY, Use 75W90	F4M21	1981-89	3.7L, 3.9L	4x2, 4 Spd, NP435 Trans, Cast Iron Tail Housing, Use 50WT Fluid	NP435-F
1990	1.6L, 1.8L	5 Spd, F5M22 Trans, CORE REQUIRED, REBUILD AND RETURN ONLY, Use 75W90	F5M22	1977-79	3.7L, 4.0L	4x2, 4 Spd, NP435 Trans, Aluminum Tail Housing, Use 50WT Fluid	NP435-G
COLT (cont.)				8 CYL			
4 CYL (cont.)				8 CYL			
1993-94	1.6L	5 Spd, F5M22 Trans, CORE REQUIRED, REBUILD AND RETURN ONLY, Use 75W90	F5M22	1990-93	5.2L, 5.9L	4x2, 5 Spd, Getrag 360, Press-In Speedo, 5W30 Used, Iron Case	G360-A
1987-89	1.5L	4 Spd, KM200 Trans, CORE REQUIRED, REBUILD AND RETURN ONLY, Use 75W90	KM200	1981-89	5.2L, 5.9L	4x2, 4 Spd, NP435 Trans, Aluminum Tail Housing, Use 50WT Fluid	NP435-G
1987-89	1.5L	5 Spd, KM201 Trans, CORE REQUIRED, REBUILD AND RETURN ONLY, Use 75W90	KM201	1981-89	5.2L, 5.9L	4x2, 4 Spd, NP435 Trans, Cast Iron Tail Housing, Use 50WT Fluid	NP435-F
1987-89	1.6L	5 Spd, KM206 Trans, CORE REQUIRED, REBUILD AND RETURN ONLY, Use 75W90	KM206	1977-79	5.2L, 5.9L, 6.6L, 7.2L	4x2, 4 Spd, NP435 Trans, Aluminum Tail Housing, Use 50WT Fluid	NP435-G

Pro King Manual Transmissions

YEAR	ENGINE	APPLICATION	PART NO.	YEAR	ENGINE	APPLICATION	PART NO.
DODGE (cont.)				DODGE (cont.)			
D150 (cont.)				D350 (cont.)			
8 CYL (cont.)				8 CYL (cont.)			
1977-79	5.2L, 5.9L, 6.6L, 7.2L	4x2, 4 Spd, NP435 Trans, Cast Iron Tail Housing, Use 50WT Fluid	NP435-F	1992-93	5.9L	4x4, 5 Spd, NV4500 Trans, REBUILDABLE CORE REQUIRED, REBUILD AND RETURN ONLY, Use Dodge# 4637579 Fluid	NV4500-O
D150 S							
6 CYL							
1990-91	3.9L	4x2, 5 Spd, Getrag 360, Press-In Speedo, 5W30 Used, Iron Case	G360-A	1981-91	5.2L, 5.9L	4x2, 4 Spd, NP435 Trans, Cast Iron Tail Housing, Use 50WT Fluid	NP435-F
8 CYL							
1990-91	5.2L	4x2, 5 Spd, Getrag 360, Press-In Speedo, 5W30 Used, Iron Case	G360-A	1981-91	5.9L	4x4, 4 Spd, NP435 Trans, Used With NP203 Or NP205 Transfer Case, Use 50WT Fluid	NP435-I
D200							
6 CYL							
1975-79	3.7L, 4.0L	4x2, 4 Spd, NP435 Trans, Aluminum Tail Housing, Use 50WT Fluid	NP435-G	1981-83	5.2L	4x2, 4 Spd, NP435 Trans, Aluminum Tail Housing, Use 50WT Fluid	NP435-G
1975-79	3.7L, 4.0L	4x2, 4 Spd, NP435 Trans, Cast Iron Tail Housing, Use 50WT Fluid	NP435-F	D400			
8 CYL				8 CYL			
1975-79	5.2L, 5.9L, 6.6L, 7.2L	4x2, 4 Spd, NP435 Trans, Aluminum Tail Housing, Use 50WT Fluid	NP435-G	1978-81	5.9L, 7.2L	4x2, 4 Spd, NP435 Trans, Aluminum Tail Housing, Use 50WT Fluid	NP435-G
1975-79	5.2L, 5.9L, 6.6L, 7.2L	4x2, 4 Spd, NP435 Trans, Cast Iron Tail Housing, Use 50WT Fluid	NP435-F	1978-81	5.9L, 7.2L	4x2, 4 Spd, NP435 Trans, Cast Iron Tail Housing, Use 50WT Fluid	NP435-F
D250				D450			
6 CYL				8 CYL			
1990-93	3.9L, 5.9L	4x2, 5 Spd, Getrag 360, Press-In Speedo, 5W30 Used, Iron Case	G360-A	1978-81	5.9L, 7.2L	4x2, 4 Spd, NP435 Trans, Aluminum Tail Housing, Use 50WT Fluid	NP435-G
1981-89	3.7L, 3.9L, 5.9L	4x2, 4 Spd, NP435 Trans, Aluminum Tail Housing, Use 50WT Fluid	NP435-G	1978-81	5.9L, 7.2L	4x2, 4 Spd, NP435 Trans, Cast Iron Tail Housing, Use 50WT Fluid	NP435-F
1981-89	3.7L, 3.9L, 5.9L	4x2, 4 Spd, NP435 Trans, Cast Iron Tail Housing, Use 50WT Fluid	NP435-F	DAKOTA			
8 CYL				4 CYL			
1990-93	5.2L, 5.9L	4x2, 5 Spd, Getrag 360, Press-In Speedo, 5W30 Used, Iron Case	G360-A	1999-02	2.5L	4x2, 5 Spd, NV1500 Trans, Aluminum Case, CORE REQUIRED, REBUILD AND RETURN ONLY, Use GM# 12377916 Fluid	NV1500-C
1981-89	5.2L, 5.9L	4x2, 4 Spd, NP435 Trans, Aluminum Tail Housing, Use 50WT Fluid	NP435-G	1998	2.5L	4x2, 5 Spd, AX15 Trans, Use Synthetic 75W90	AX15-IE
1981-89	5.2L, 5.9L	4x2, 4 Spd, NP435 Trans, Cast Iron Tail Housing, Use 50WT Fluid	NP435-F	1997	2.5L	4x2, 5 Spd, AX15 Trans, Use Synthetic 75W90	AX15-IC
D350				1995-96 2.5L 4x2, 5 Spd, AX15 Trans, Use Synthetic 75W90 AX15-IB			
6 CYL				1994-95 2.5L 4x2, 5 Spd, AX15 Trans, Use Synthetic 75W90 AX15-IA			
1989-93	5.9L	4x2, 5 Spd, Getrag 360, Press-In Speedo, 5W30 Used, Iron Case	G360-A	6 CYL			
1989-93	5.9L	4x4, 5 Spd, Getrag 360, No Speedo, 5W30 Used, Iron Case	G360-B	2000-03	3.9L	4x2, 5 Spd, NV3500 Trans, Aluminum Case, Use MOPAR# 4874464 Fluid	NV3500-E
8 CYL				2000-03 3.9L 4x4, 5 Spd, NV3500 Trans, Aluminum Case, Use MOPAR# 4874464 Fluid NV3500-F			
1992-93	5.9L	4x2, 5 Spd, NV4500 Trans, REBUILDABLE CORE REQUIRED, REBUILD AND RETURN ONLY, Use Dodge# 4637579 Fluid	NV4500-R	1998-99	3.9L	4x2, 5 Spd, AX15 Trans, Use Synthetic 75W90	AX15-IF
				1997 3.9L 4x2, 5 Spd, AX15 Trans, Use Synthetic 75W90 AX15-ID			
				1994-99 3.9L 4x4, 5 Spd, AX15 Trans, No Speedo, 75w90 Used, External Slave Cylinder .750" Pilot AX15-H			
				1994-96 3.9L 4x2, 5 Spd, AX15 Trans, Use Synthetic 75W90 AX15-IA			
				8 CYL			
				2000-03 4.7L, 5.9L 4x2, 5 Spd, NV3500 Trans, Aluminum Case, Use MOPAR# 4874464 Fluid NV3500-E			

Pro King Manual Transmissions

YEAR	ENGINE	APPLICATION	PART NO.	YEAR	ENGINE	APPLICATION	PART NO.
DODGE (cont.)				DODGE (cont.)			
DAKOTA (cont.)				NEON (cont.)			
8 CYL (cont.)				4 CYL (cont.)			
2000-02	5.9L	4x2, 5 Spd, NV1500 Trans, Aluminum Case, CORE REQUIRED, REBUILD AND RETURN ONLY, Use GM# 12377916 Fluid	NV1500-C	1995-98	2.0L	5 Spd, All Aluminum Case, Hydraulic Operated Clutch, Use MOPAR# 4874465 Fluid	A578-B
1998-99	5.2L	4x2, 5 Spd, NV3500 Trans, w/o Speedo, Use MOPAR# 4874464 Fluid	NV3500-CA	RAM 1500			
1994-97	5.2L	4x2, 5 Spd, NV3500 Trans, CORE REQUIRED, REBUILD AND RETURN ONLY, Screw-In Speedo, 17.5" Tail Housing, Shifter In Tail Housing, Use MOPAR# 4874464 Fluid	NV3500-C	6 CYL			
1994-03	4.7L, 5.2L, 5.9L	4x4, 5 Spd, NV3500 Trans, Aluminum Case, Use MOPAR# 4874464 Fluid	NV3500-F	2004	3.7L	4x2, 5 Spd, NV3500 Trans, Use MOPAR# 4874464 Fluid	NV3500-GA
DART				2004	3.7L	4x4, 5 Spd, NV3500 Trans, Use MOPAR# 4874464 Fluid	NV3500-HA
6 CYL				1998	3.9L	4x2, 5 Spd, NV3500 Trans, Aluminum Case, Use MOPAR# 4874464 Fluid	NV3500-G
1975-76	3.7L	4 Spd, NP833 Trans (3 Spd w/OD), Iron Case Or Aluminum Case, 10 Bolt Side Cover, CORE REQUIRED, REBUILD AND RETURN ONLY, Use ATF	NP833O/D	1998	3.9L	4x4, 5 Spd, NV3500 Trans, Aluminum Case, Use MOPAR# 4874464 Fluid	NV3500-H
1975	3.7L	4 Spd, NP833 Trans, Iron Case Non Overdrive, 10 Bolt Side Cover, CORE REQUIRED, REBUILD AND RETURN ONLY, Use 80W90	NP833	1994-97	3.9L	4x2, 5 Spd, NV3500 Trans, CORE REQUIRED, REBUILD AND RETURN ONLY, Electric Speedo Screw in, 17.5" Tail Housing, Shifter In Rear Of Case, Use MOPAR# 4874464 Fluid	NV3500-A
8 CYL				1994-97	3.9L	4x4, 5 Spd, NV3500 Trans, No Speedo, 12" Tail Housing, Shifter In Rear Of Case, Use MOPAR# 4874464 Fluid	NV3500-B
1975-76	5.2L, 5.9L	4 Spd, NP833 Trans (3 Spd w/OD), Iron Case Or Aluminum Case, 10 Bolt Side Cover, CORE REQUIRED, REBUILD AND RETURN ONLY, Use ATF	NP833O/D	8 CYL			
1975	5.2L, 5.9L	4 Spd, NP833 Trans, Iron Case Non Overdrive, 10 Bolt Side Cover, CORE REQUIRED, REBUILD AND RETURN ONLY, Use 80W90	NP833	2004	4.7L	4x2, 5 Spd, NV3500 Trans, Use MOPAR# 4874464 Fluid	NV3500-GA
DIPLOMAT				2004	4.7L	4x4, 5 Spd, NV3500 Trans, Use MOPAR# 4874464 Fluid	NV3500-HA
6 CYL				2004	5.7L	4x2, 5 Spd, NV4500 Trans, No Speedo, 10 Spline Input, 12" Tail Housing, Square Top Cover, REBUILDABLE CORE REQUIRED, REBUILD AND RETURN ONLY, Use MOPAR# 4637579 Fluid	NV4500-Q
1978	3.7L	4 Spd, NP833 Trans (3 Spd w/OD), Iron Case Or Aluminum Case, 10 Bolt Side Cover, CORE REQUIRED, REBUILD AND RETURN ONLY, Use ATF	NP833O/D	2004	5.7L	4x4, 5 Spd, NV4500 Trans, 10 Spline Input Shaft, Use MOPAR# 4637579 Fluid	NV4500-NA
8 CYL				1998	5.2L, 5.9L	4x2, 5 Spd, NV3500 Trans, Aluminum Case, Use MOPAR# 4874464 Fluid	NV3500-G
1978	5.2L, 5.9L	4 Spd, NP833 Trans (3 Spd w/OD), Iron Case Or Aluminum Case, 10 Bolt Side Cover, CORE REQUIRED, REBUILD AND RETURN ONLY, Use ATF	NP833O/D	1998	5.2L, 5.9L	4x4, 5 Spd, NV3500 Trans, Aluminum Case, Use MOPAR# 4874464 Fluid	NV3500-H
NEON				1994-97	5.2L, 5.9L	4x2, 5 Spd, NV3500 Trans, CORE REQUIRED, REBUILD AND RETURN ONLY, Electric Speedo Screw in, 17.5" Tail Housing, Shifter In Rear Of Case, Use MOPAR# 4874464 Fluid	NV3500-A
4 CYL				1994-97	5.2L, 5.9L	4x4, 5 Spd, NV3500 Trans, No Speedo, 12" Tail Housing, Shifter In Rear Of Case, Use MOPAR# 4874464 Fluid	NV3500-B
1995-98	2.0L	5 Spd, All Aluminum Case, Cable Operated Clutch, Use MOPAR# 4874465 Fluid	A578-A				

Pro King Manual Transmissions

YEAR	ENGINE	APPLICATION	PART NO.	YEAR	ENGINE	APPLICATION	PART NO.
DODGE (cont.)				DODGE (cont.)			
RAM 1500 PICKUP & VAN				RAM 2500 (cont.)			
6 CYL				6 CYL (cont.)			
2002-03	3.7L	4x2, 5 Spd, NV3500 Trans, Use MOPAR# 4874464 Fluid	NV3500-GA	1998	5.9L	4x4, 6 Spd, NV5600 Trans, Non High Output Engine, 1 1/4" Diameter Input Shaft, CORE REQUIRED, REBUILD AND RETURN ONLY, Use MOPAR# 4874464 Fluid	NV5600-B
2002-03	3.7L	4x4, 5 Spd, NV3500 Trans, Use MOPAR# 4874464 Fluid	NV3500-HA	1994-97	5.9L	4x2, 5 Spd, NV4500 Trans, W/Speedo, Push & Twist Top Cover, Use MOPAR# 4637579 Fluid	NV4500-L
1999-01	3.9L	4x2, 5 Spd, NV3500 Trans, Aluminum Case, Use MOPAR# 4874464 Fluid	NV3500-G	1994-97	5.9L	4x4, 5 Spd, NV4500 Trans, No Speedo, 12" Tail Housing, Push-in Twist Top Cover, Use MOPAR# 4637579 Fluid	NV4500-K
1999-01	3.9L	4x4, 5 Spd, NV3500 Trans, Aluminum Case, Use MOPAR# 4874464 Fluid	NV3500-H				
8 CYL				8 CYL			
2003	5.7L	4x2, 5 Spd, NV4500 Trans, No Speedo, 10 Spline Input, 12" Tail Housing, Square Top Cover, REBUILDABLE CORE REQUIRED, REBUILD AND RETURN ONLY, Use MOPAR# 4637579 Fluid	NV4500-Q	2004-05	5.7L	4x2, 5 Spd, NV4500 Trans, REBUILDABLE CORE REQUIRED, REBUILD AND RETURN ONLY, Use MOPAR# 4637579 Fluid	NV4500-QA
2003	5.7L	4x4, 5 Spd, NV4500 Trans, 10 Spline Input Shaft, Use MOPAR# 4637579 Fluid	NV4500-NA	2004-05	5.7L	4x4, 5 Spd, NV4500 Trans, Use MOPAR# 4637579 Fluid	NV4500-NB
2002-03	4.7L	4x2, 5 Spd, NV3500 Trans, Use MOPAR# 4874464 Fluid	NV3500-GA	1998	5.9L	4x2, 5 Spd, NV4500 Trans, No Speedo, 10 Spline Input, 12" Tail Housing, Square Top Cover, REBUILDABLE CORE REQUIRED, REBUILD AND RETURN ONLY, Use MOPAR# 4637579 Fluid	NV4500-Q
2002-03	4.7L	4x4, 5 Spd, NV3500 Trans, Use MOPAR# 4874464 Fluid	NV3500-HA	1998	5.9L	4x4, 5 Spd, NV4500 Trans, 10 Spline Input Shaft, Use MOPAR# 4637579 Fluid	NV4500-NA
1999-03	5.2L, 5.9L	4x2, 5 Spd, NV3500 Trans, Aluminum Case, Use MOPAR# 4874464 Fluid	NV3500-G	1998	5.9L	4x4, 5 Spd, NV4500 Trans, Use MOPAR# 4637579 Fluid	NV4500-NB
1999-03	5.2L, 5.9L	4x4, 5 Spd, NV3500 Trans, Aluminum Case, Use MOPAR# 4874464 Fluid	NV3500-H	1994-97	5.2L, 5.9L	4x2, 5 Spd, NV4500 Trans, 10 Spline Input Shaft, REBUILDABLE CORE REQUIRED, REBUILD AND RETURN ONLY, Use MOPAR# 4637579 Fluid	NV4500-P
RAM 2500				1994-97	5.2L, 5.9L	4x4, 5 Spd, NV4500 Trans, 10 Spline Input Shaft, Use MOPAR# 4637579 Fluid	NV4500-N
6 CYL				1994-96	5.2L	4x2, 5 Spd, NV3500 Trans, CORE REQUIRED, REBUILD AND RETURN ONLY, Electric Speedo Screw in, 17.5" Tail Housing, Shifter In Rear Of Case, Use MOPAR# 4874464 Fluid	NV3500-A
2004-05	5.9L	4x2, 6 Spd, NV5600 Trans, High Output Engine, 1 3/8" Diameter Input Shaft, CORE REQUIRED, REBUILD AND RETURN ONLY, Use MOPAR# 4874464 Fluid	NV5600-C	1994-96	5.2L	4x4, 5 Spd, NV3500 Trans, No Speedo, 12" Tail Housing, Shifter In Rear Of Case, Use MOPAR# 4874464 Fluid	NV3500-B
2004-05	5.9L	4x4, 6 Spd, NV5600 Trans, High Output Engine, 1 3/8" Diameter Input Shaft, CORE REQUIRED, REBUILD AND RETURN ONLY, Use MOPAR# 4874464 Fluid	NV5600-D				
2004	5.9L	4x2, 5 Spd, NV4500 Trans, No Speedo, 12" Tail Housing, Square Top cover, Use MOPAR# 4637579 Fluid	NV4500-M	10 CYL			
1998	5.9L	4x2, 5 Spd, NV4500 Trans, No Speedo, 12" Tail Housing, Square Top cover, Use MOPAR# 4637579 Fluid	NV4500-M	1998	8.0L	4x2, 5 Spd, NV4500 Trans, No Speedo, 12" Tail Housing, Square Top cover, Use MOPAR# 4637579 Fluid	NV4500-M
1998	5.9L	4x2, 6 Spd, NV5600 Trans, Non High Output Engine, 1 1/4" Diameter Input Shaft, CORE REQUIRED, REBUILD AND RETURN ONLY, Use MOPAR# 4874464 Fluid	NV5600-A	1998	8.0L	4x4, 5 Spd, NV4500 Trans, No Speedo, Use MOPAR# 4637579 Fluid	NV4500-KA
1998	5.9L	4x4, 5 Spd, NV4500 Trans, No Speedo, Use MOPAR# 4637579 Fluid	NV4500-KA				

Pro King Manual Transmissions

YEAR	ENGINE	APPLICATION	PART NO.	YEAR	ENGINE	APPLICATION	PART NO.
DODGE (cont.)				DODGE (cont.)			
RAM 2500 (cont.)				RAM 2500 PICKUP & VAN (cont.)			
10 CYL (cont.)				8 CYL			
1994-97	8.0L	4x2, 5 Spd, NV4500 Trans, W/Speedo, Push & Twist Top Cover, Use MOPAR# 4637579 Fluid	NV4500-L	2003	5.7L	4x2, 5 Spd, NV4500 Trans, REBUILDABLE CORE REQUIRED, REBUILD AND RETURN ONLY, Use MOPAR# 4637579 Fluid	NV4500-QA
1994-97	8.0L	4x4, 5 Spd, NV4500 Trans, No Speedo, 12" Tail Housing, Push-in Twist Top Cover, Use MOPAR# 4637579 Fluid	NV4500-K	2003	5.7L	4x4, 5 Spd, NV4500 Trans, Use MOPAR# 4637579 Fluid	NV4500-NB
RAM 2500 CLUB CAB				1999-02	5.9L	4x2, 5 Spd, NV4500 Trans, No Speedo, 10 Spline Input, 12" Tail Housing, Square Top Cover, REBUILDABLE CORE REQUIRED, REBUILD AND RETURN ONLY, Use MOPAR# 4637579 Fluid	NV4500-Q
6 CYL				1999-02	5.9L	4x4, 5 Spd, NV4500 Trans, 10 Spline Input Shaft, Use MOPAR# 4637579 Fluid	NV4500-NA
1998	5.9L	4x2, 5 Spd, NV4500 Trans, No Speedo, 12" Tail Housing, Square Top cover, Use MOPAR# 4637579 Fluid	NV4500-M	1999-01	5.9L	4x4, 5 Spd, NV4500 Trans, Use MOPAR# 4637579 Fluid	NV4500-NB
1998	5.9L	4x2, 6 Spd, NV5600 Trans, Non High Output Engine, 1 1/4" Diameter Input Shaft, CORE REQUIRED, REBUILD AND RETURN ONLY, Use MOPAR# 4874464 Fluid	NV5600-A	10 CYL			
1998	5.9L	4x4, 5 Spd, NV4500 Trans, No Speedo, Use MOPAR# 4637579 Fluid	NV4500-KA	1999-03	8.0L	4x2, 5 Spd, NV4500 Trans, No Speedo, 12" Tail Housing, Square Top cover, Use MOPAR# 4637579 Fluid	NV4500-M
1998	5.9L	4x4, 6 Spd, NV5600 Trans, Non High Output Engine, 1 1/4" Diameter Input Shaft, CORE REQUIRED, REBUILD AND RETURN ONLY, Use MOPAR# 4874464 Fluid	NV5600-B	1999-03	8.0L	4x4, 5 Spd, NV4500 Trans, No Speedo, Use MOPAR# 4637579 Fluid	NV4500-KA
RAM 2500 PICKUP & VAN				RAM 2500 QUAD CAB			
6 CYL				6 CYL			
2000-03	5.9L	4x2, 6 Spd, NV5600 Trans, High Output Engine, 1 3/8" Diameter Input Shaft, CORE REQUIRED, REBUILD AND RETURN ONLY, Use MOPAR# 4874464 Fluid	NV5600-C	1998	5.9L	4x2, 5 Spd, NV4500 Trans, No Speedo, 12" Tail Housing, Square Top cover, Use MOPAR# 4637579 Fluid	NV4500-M
2000-03	5.9L	4x4, 6 Spd, NV5600 Trans, High Output Engine, 1 3/8" Diameter Input Shaft, CORE REQUIRED, REBUILD AND RETURN ONLY, Use MOPAR# 4874464 Fluid	NV5600-D	1998	5.9L	4x2, 6 Spd, NV5600 Trans, Non High Output Engine, 1 1/4" Diameter Input Shaft, CORE REQUIRED, REBUILD AND RETURN ONLY, Use MOPAR# 4874464 Fluid	NV5600-A
1999-03	5.9L	4x2, 5 Spd, NV4500 Trans, No Speedo, 12" Tail Housing, Square Top cover, Use MOPAR# 4637579 Fluid	NV4500-M	1998	5.9L	4x4, 5 Spd, NV4500 Trans, No Speedo, Use MOPAR# 4637579 Fluid	NV4500-KA
1999-01	5.9L	4x4, 5 Spd, NV4500 Trans, No Speedo, Use MOPAR# 4637579 Fluid	NV4500-KA	1998	5.9L	4x4, 6 Spd, NV5600 Trans, Non High Output Engine, 1 1/4" Diameter Input Shaft, CORE REQUIRED, REBUILD AND RETURN ONLY, Use MOPAR# 4874464 Fluid	NV5600-B
1999-00	5.9L	4x2, 6 Spd, NV5600 Trans, Non High Output Engine, 1 1/4" Diameter Input Shaft, CORE REQUIRED, REBUILD AND RETURN ONLY, Use MOPAR# 4874464 Fluid	NV5600-A	RAM 3500			
1999-00	5.9L	4x4, 6 Spd, NV5600 Trans, Non High Output Engine, 1 1/4" Diameter Input Shaft, CORE REQUIRED, REBUILD AND RETURN ONLY, Use MOPAR# 4874464 Fluid	NV5600-B	6 CYL			
				2004-05	5.9L	4x2, 6 Spd, NV5600 Trans, High Output Engine, 1 3/8" Diameter Input Shaft, CORE REQUIRED, REBUILD AND RETURN ONLY, Use MOPAR# 4874464 Fluid	NV5600-C
				2004-05	5.9L	4x4, 6 Spd, NV5600 Trans, High Output Engine, 1 3/8" Diameter Input Shaft, CORE REQUIRED, REBUILD AND RETURN ONLY, Use MOPAR# 4874464 Fluid	NV5600-D

Pro King Manual Transmissions

YEAR	ENGINE	APPLICATION	PART NO.	YEAR	ENGINE	APPLICATION	PART NO.
DODGE (cont.)				DODGE (cont.)			
RAM 3500 (cont.)				RAM 3500 (cont.)			
6 CYL (cont.)				10 CYL (cont.)			
2004	5.9L	4x2, 5 Spd, NV4500 Trans, No Speedo, 12" Tail Housing, Square Top cover, Use MOPAR# 4637579 Fluid	NV4500-M	1994-97	8.0L	4x4, 5 Spd, NV4500 Trans, No Speedo, 12" Tail Housing, Square Top Cover, Use MOPAR# 4637579 Fluid	NV4500-K
2004	5.9L	4x4, 5 Spd, NV4500 Trans, No Speedo, Use MOPAR# 4637579 Fluid	NV4500-KA	RAM 3500 PICKUP & VAN			
1998	5.9L	4x2, 5 Spd, NV4500 Trans, No Speedo, 12" Tail Housing, Square Top cover, Use MOPAR# 4637579 Fluid	NV4500-M	6 CYL			
1998	5.9L	4x2, 6 Spd, NV5600 Trans, Non High Output Engine, 1 1/4" Diameter Input Shaft, CORE REQUIRED, REBUILD AND RETURN ONLY, Use MOPAR# 4874464 Fluid	NV5600-A	2000-03	5.9L	4x2, 6 Spd, NV5600 Trans, High Output Engine, 1 3/8" Diameter Input Shaft, CORE REQUIRED, REBUILD AND RETURN ONLY, Use MOPAR# 4874464 Fluid	NV5600-C
1998	5.9L	4x4, 5 Spd, NV4500 Trans, No Speedo, Use MOPAR# 4637579 Fluid	NV4500-KA	2000-03	5.9L	4x4, 6 Spd, NV5600 Trans, High Output Engine, 1 3/8" Diameter Input Shaft, CORE REQUIRED, REBUILD AND RETURN ONLY, Use MOPAR# 4874464 Fluid	NV5600-D
1998	5.9L	4x4, 6 Spd, NV5600 Trans, Non High Output Engine, 1 1/4" Diameter Input Shaft, CORE REQUIRED, REBUILD AND RETURN ONLY, Use MOPAR# 4874464 Fluid	NV5600-B	1999-03	5.9L	4x2, 5 Spd, NV4500 Trans, No Speedo, 12" Tail Housing, Square Top cover, Use MOPAR# 4637579 Fluid	NV4500-M
1994-97	5.9L	4x4, 5 Spd, NV4500 Trans, No Speedo, 12" Tail Housing, Square Top Cover, Use MOPAR# 4637579 Fluid	NV4500-K	1999-03	5.9L	4x4, 5 Spd, NV4500 Trans, No Speedo, Use MOPAR# 4637579 Fluid	NV4500-KA
8 CYL				1999-00	5.9L	4x2, 6 Spd, NV5600 Trans, Non High Output Engine, 1 1/4" Diameter Input Shaft, CORE REQUIRED, REBUILD AND RETURN ONLY, Use MOPAR# 4874464 Fluid	NV5600-A
2004-05	5.7L	4x2, 5 Spd, NV4500 Trans, REBUILDABLE CORE REQUIRED, REBUILD AND RETURN ONLY, Use MOPAR# 4637579 Fluid	NV4500-QA	1999-00	5.9L	4x4, 6 Spd, NV5600 Trans, Non High Output Engine, 1 1/4" Diameter Input Shaft, CORE REQUIRED, REBUILD AND RETURN ONLY, Use MOPAR# 4874464 Fluid	NV5600-B
2004-05	5.7L	4x4, 5 Spd, NV4500 Trans, Use MOPAR# 4637579 Fluid	NV4500-NB	8 CYL			
1998	5.9L	4x2, 5 Spd, NV4500 Trans, No Speedo, 10 Spline Input, 12" Tail Housing, Square Top Cover, REBUILDABLE CORE REQUIRED, REBUILD AND RETURN ONLY, Use MOPAR# 4637579 Fluid	NV4500-Q	2003	5.7L	4x2, 5 Spd, NV4500 Trans, REBUILDABLE CORE REQUIRED, REBUILD AND RETURN ONLY, Use MOPAR# 4637579 Fluid	NV4500-QA
1998	5.9L	4x4, 5 Spd, NV4500 Trans, 10 Spline Input Shaft, Use MOPAR# 4637579 Fluid	NV4500-NA	1999-03	5.7L, 5.9L	4x4, 5 Spd, NV4500 Trans, Use MOPAR# 4637579 Fluid	NV4500-NB
1998	5.9L	4x4, 5 Spd, NV4500 Trans, Use MOPAR# 4637579 Fluid	NV4500-NB	1999-02	5.9L	4x2, 5 Spd, NV4500 Trans, No Speedo, 10 Spline Input, 12" Tail Housing, Square Top Cover, REBUILDABLE CORE REQUIRED, REBUILD AND RETURN ONLY, Use MOPAR# 4637579 Fluid	NV4500-Q
10 CYL				1999-02	5.9L	4x4, 5 Spd, NV4500 Trans, 10 Spline Input Shaft, Use MOPAR# 4637579 Fluid	NV4500-NA
1998	8.0L	4x2, 5 Spd, NV4500 Trans, No Speedo, 12" Tail Housing, Square Top cover, Use MOPAR# 4637579 Fluid	NV4500-M	1999-02	5.9L	4x4, 5 Spd, NV4500 Trans, 10 Spline Input Shaft, Use MOPAR# 4637579 Fluid	NV4500-NA
1998	8.0L	4x4, 5 Spd, NV4500 Trans, No Speedo, Use MOPAR# 4637579 Fluid	NV4500-KA	10 CYL			
1994-97	8.0L	4x2, 5 Spd, NV4500 Trans, W/Speedo, Push & Twist Top Cover, Use MOPAR# 4637579 Fluid	NV4500-L	1999-03	8.0L	4x2, 5 Spd, NV4500 Trans, No Speedo, 12" Tail Housing, Square Top cover, Use MOPAR# 4637579 Fluid	NV4500-M
				1999-03	8.0L	4x4, 5 Spd, NV4500 Trans, No Speedo, Use MOPAR# 4637579 Fluid	NV4500-KA

Pro King Manual Transmissions

YEAR	ENGINE	APPLICATION	PART NO.	YEAR	ENGINE	APPLICATION	PART NO.
DODGE (cont.)				DODGE (cont.)			
RAM 3500 QUAD CAB				STRATUS			
6 CYL				4 CYL			
1998	5.9L	4x2, 5 Spd, NV4500 Trans, No Speedo, 12" Tail Housing, Square Top cover, Use MOPAR# 4637579 Fluid	NV4500-M	1995-98	2.0L, 2.4L	5 Spd, All Aluminum Case, Cable Operated Clutch, Use MOPAR# 4874465 Fluid	A578-A
1998	5.9L	4x2, 6 Spd, NV5600 Trans, Non High Output Engine, 1 1/4" Diameter Input Shaft, CORE REQUIRED, REBUILD AND RETURN ONLY, Use MOPAR# 4874464 Fluid	NV5600-A	1995-98	2.0L, 2.4L	5 Spd, All Aluminum Case, Hydraulic Operated Clutch, Use MOPAR# 4874465 Fluid	A578-B
1998	5.9L	4x4, 5 Spd, NV4500 Trans, No Speedo, Use MOPAR# 4637579 Fluid	NV4500-KA	VIPER			
1998	5.9L	4x4, 6 Spd, NV5600 Trans, Non High Output Engine, 1 1/4" Diameter Input Shaft, CORE REQUIRED, REBUILD AND RETURN ONLY, Use MOPAR# 4874464 Fluid	NV5600-B	10 CYL			
8 CYL				1993-06	8.0L, 8.3L	6 Spd, T56 Trans, REBUILDABLE CORE REQUIRED, REBUILD AND RETURN ONLY, Use ATF	T56-D
1998	5.9L	4x2, 5 Spd, NV4500 Trans, No Speedo, 10 Spline Input, 12" Tail Housing, Square Top Cover, REBUILDABLE CORE REQUIRED, REBUILD AND RETURN ONLY, Use MOPAR# 4637579 Fluid	NV4500-Q	W100			
1998	5.9L	4x4, 5 Spd, NV4500 Trans, 10 Spline Input Shaft, Use MOPAR# 4637579 Fluid	NV4500-NA	6 CYL			
1998	5.9L	4x4, 5 Spd, NV4500 Trans, Use MOPAR# 4637579 Fluid	NV4500-NB	1989	3.9L	4x4, 4 Spd, NP435 Trans, Used With Divorced Transfer Cases, Use 50WT Fluid	NP435-J
RAM 50				1989	3.9L	4x4, 4 Spd, NP435 Trans, Used With NP203 Or NP205 Transfer Case, Use 50WT Fluid	NP435-I
4 CYL				1989	3.9L	4x4, 4 Spd, NP435 Trans, Used With NP208 Transfer Case, Use 50WT Fluid	NP435-H
1987-89	2.0L	4x4, 5 Spd, KM145 Trans, Cable Operated Clutch	KM145-1	1986-87	3.7L	4x4, 4 Spd, NP435 Trans, Used With Divorced Transfer Cases, Use 50WT Fluid	NP435-J
RAMCHARGER				1986-87	3.7L	4x4, 4 Spd, NP435 Trans, Used With NP203 Or NP205 Transfer Case, Use 50WT Fluid	NP435-I
8 CYL				1986-87	3.7L	4x4, 4 Spd, NP435 Trans, Used With NP208 Transfer Case, Use 50WT Fluid	NP435-H
1982-93	5.2L, 5.9L	4x2, 4 Spd, NP435 Trans, Aluminum Tail Housing, Use 50WT Fluid	NP435-G	1975-77	3.7L	4x4, 4 Spd, NP435 Trans, Used With Divorced Transfer Cases, Use 50WT Fluid	NP435-J
1982-93	5.2L, 5.9L	4x2, 4 Spd, NP435 Trans, Cast Iron Tail Housing, Use 50WT Fluid	NP435-F	1975-77	3.7L	4x4, 4 Spd, NP435 Trans, Used With NP203 Or NP205 Transfer Case, Use 50WT Fluid	NP435-I
1982-93	5.2L, 5.9L	4x4, 4 Spd, NP435 Trans, Used With Divorced Transfer Cases, Use 50WT Fluid	NP435-J	1975-77	3.7L	4x4, 4 Spd, NP435 Trans, Used With NP208 Transfer Case, Use 50WT Fluid	NP435-H
1982-93	5.2L, 5.9L	4x4, 4 Spd, NP435 Trans, Used With NP203 Or NP205 Transfer Case, Use 50WT Fluid	NP435-I	8 CYL			
1982-93	5.2L, 5.9L	4x4, 4 Spd, NP435 Trans, Used With NP208 Transfer Case, Use 50WT Fluid	NP435-H	1986-89	5.2L, 5.9L	4x4, 4 Spd, NP435 Trans, Used With Divorced Transfer Cases, Use 50WT Fluid	NP435-J
STEALTH				1986-89	5.2L, 5.9L	4x4, 4 Spd, NP435 Trans, Used With NP203 Or NP205 Transfer Case, Use 50WT Fluid	NP435-I
6 CYL				1986-89	5.2L, 5.9L	4x4, 4 Spd, NP435 Trans, Used With NP208 Transfer Case, Use 50WT Fluid	NP435-H
1991-94	3.0L	4x4, 5 Spd, W5MG1 Trans, 12 Bolt Aluminum Cover Over 5th Gears, REBUILDABLE CORE REQUIRED, REBUILD AND RETURN ONLY, Use 75W90	W5MG1	1975-77	5.2L, 5.9L, 6.6L, 7.2L	4x4, 4 Spd, NP435 Trans, Used With Divorced Transfer Cases, Use 50WT Fluid	NP435-J
				1975-77	5.2L, 5.9L, 6.6L, 7.2L	4x4, 4 Spd, NP435 Trans, Used With NP203 Or NP205 Transfer Case, Use 50WT Fluid	NP435-I
				1975-77	5.2L, 5.9L, 6.6L, 7.2L	4x4, 4 Spd, NP435 Trans, Used With NP208 Transfer Case, Use 50WT Fluid	NP435-H

Pro King Manual Transmissions

YEAR	ENGINE	APPLICATION	PART NO.	YEAR	ENGINE	APPLICATION	PART NO.
DODGE (cont.)				DODGE (cont.)			
W150				W150 S (cont.)			
6 CYL				8 CYL (cont.)			
1989-93	3.9L	4x4, 4 Spd, NP435 Trans, Used With Divorced Transfer Cases, Use 50WT Fluid	NP435-J	1990-91	5.2L, 5.9L	4x4, 4 Spd, NP435 Trans, Used With NP203 Or NP205 Transfer Case, Use 50WT Fluid	NP435-I
1989-93	3.9L	4x4, 4 Spd, NP435 Trans, Used With NP203 Or NP205 Transfer Case, Use 50WT Fluid	NP435-I	1990-91	5.2L, 5.9L	4x4, 4 Spd, NP435 Trans, Used With NP208 Transfer Case, Use 50WT Fluid	NP435-H
1989-93	3.9L	4x4, 4 Spd, NP435 Trans, Used With NP208 Transfer Case, Use 50WT Fluid	NP435-H	W200			
1981-87	3.7L	4x4, 4 Spd, NP435 Trans, Used With Divorced Transfer Cases, Use 50WT Fluid	NP435-J	6 CYL			
1981-87	3.7L	4x4, 4 Spd, NP435 Trans, Used With NP203 Or NP205 Transfer Case, Use 50WT Fluid	NP435-I	1975-79	3.7L, 4.0L	4x4, 4 Spd, NP435 Trans, Used With Divorced Transfer Cases, Use 50WT Fluid	NP435-J
1981-87	3.7L	4x4, 4 Spd, NP435 Trans, Used With NP208 Transfer Case, Use 50WT Fluid	NP435-H	1975-79	3.7L, 4.0L	4x4, 4 Spd, NP435 Trans, Used With NP203 Or NP205 Transfer Case, Use 50WT Fluid	NP435-I
1978-79	3.7L, 4.0L	4x4, 4 Spd, NP435 Trans, Used With Divorced Transfer Cases, Use 50WT Fluid	NP435-J	1975-79	3.7L, 4.0L	4x4, 4 Spd, NP435 Trans, Used With NP208 Transfer Case, Use 50WT Fluid	NP435-H
1978-79	3.7L, 4.0L	4x4, 4 Spd, NP435 Trans, Used With NP203 Or NP205 Transfer Case, Use 50WT Fluid	NP435-I	8 CYL			
1978-79	3.7L, 4.0L	4x4, 4 Spd, NP435 Trans, Used With NP208 Transfer Case, Use 50WT Fluid	NP435-H	1975-79	5.2L, 5.9L, 6.6L, 7.2L	4x4, 4 Spd, NP435 Trans, Used With Divorced Transfer Cases, Use 50WT Fluid	NP435-J
8 CYL				1975-79	5.2L, 5.9L, 6.6L, 7.2L	4x4, 4 Spd, NP435 Trans, Used With NP203 Or NP205 Transfer Case, Use 50WT Fluid	NP435-I
1981-93	5.2L, 5.9L	4x4, 4 Spd, NP435 Trans, Used With Divorced Transfer Cases, Use 50WT Fluid	NP435-J	1975-79	5.2L, 5.9L, 6.6L, 7.2L	4x4, 4 Spd, NP435 Trans, Used With NP208 Transfer Case, Use 50WT Fluid	NP435-H
1981-93	5.2L, 5.9L	4x4, 4 Spd, NP435 Trans, Used With NP203 Or NP205 Transfer Case, Use 50WT Fluid	NP435-I	W250			
1981-93	5.2L, 5.9L	4x4, 4 Spd, NP435 Trans, Used With NP208 Transfer Case, Use 50WT Fluid	NP435-H	6 CYL			
1977-79	5.2L, 5.9L, 6.6L, 7.2L	4x4, 4 Spd, NP435 Trans, Used With Divorced Transfer Cases, Use 50WT Fluid	NP435-J	1990-93	5.9L	4x4, 5 Spd, Getrag 360, No Speedo, 5W30 Used, Iron Case	G360-B
1977-79	5.2L, 5.9L, 6.6L, 7.2L	4x4, 4 Spd, NP435 Trans, Used With NP203 Or NP205 Transfer Case, Use 50WT Fluid	NP435-I	1989	5.9L	4x4, 4 Spd, NP435 Trans, Used With Divorced Transfer Cases, Use 50WT Fluid	NP435-J
1977-79	5.2L, 5.9L, 6.6L, 7.2L	4x4, 4 Spd, NP435 Trans, Used With NP208 Transfer Case, Use 50WT Fluid	NP435-H	1989	5.9L	4x4, 4 Spd, NP435 Trans, Used With NP203 Or NP205 Transfer Case, Use 50WT Fluid	NP435-I
W150 S				1989	5.9L	4x4, 4 Spd, NP435 Trans, Used With NP208 Transfer Case, Use 50WT Fluid	NP435-H
6 CYL				8 CYL			
1990-91	3.9L	4x4, 4 Spd, NP435 Trans, Used With Divorced Transfer Cases, Use 50WT Fluid	NP435-J	1990-93	5.2L, 5.9L	4x4, 5 Spd, Getrag 360, No Speedo, 5W30 Used, Iron Case	G360-B
1990-91	3.9L	4x4, 4 Spd, NP435 Trans, Used With NP203 Or NP205 Transfer Case, Use 50WT Fluid	NP435-I	1981-89	5.2L, 5.9L	4x4, 4 Spd, NP435 Trans, Used With Divorced Transfer Cases, Use 50WT Fluid	NP435-J
1990-91	3.9L	4x4, 4 Spd, NP435 Trans, Used With NP208 Transfer Case, Use 50WT Fluid	NP435-H	1981-89	5.2L, 5.9L	4x4, 4 Spd, NP435 Trans, Used With NP203 Or NP205 Transfer Case, Use 50WT Fluid	NP435-I
8 CYL				1981-89	5.2L, 5.9L	4x4, 4 Spd, NP435 Trans, Used With NP208 Transfer Case, Use 50WT Fluid	NP435-H
1990-91	5.2L, 5.9L	4x4, 4 Spd, NP435 Trans, Used With Divorced Transfer Cases, Use 50WT Fluid	NP435-J	W300			
6 CYL				6 CYL			
1975-78	3.7L	4x4, 4 Spd, NP435 Trans, Used With Divorced Transfer Cases, Use 50WT Fluid	NP435-J	1975-78	3.7L	4x4, 4 Spd, NP435 Trans, Used With Divorced Transfer Cases, Use 50WT Fluid	NP435-J
1975-78	3.7L	4x4, 4 Spd, NP435 Trans, Used With NP203 Or NP205 Transfer Case, Use 50WT Fluid	NP435-I	1975-78	3.7L	4x4, 4 Spd, NP435 Trans, Used With NP203 Or NP205 Transfer Case, Use 50WT Fluid	NP435-I

Pro King Manual Transmissions

YEAR	ENGINE	APPLICATION	PART NO.	YEAR	ENGINE	APPLICATION	PART NO.
DODGE (cont.)				EAGLE (cont.)			
W300 (cont.)				SUMMIT (cont.)			
6 CYL (cont.)				4 CYL (cont.)			
1975-78	3.7L	4x4, 4 Spd, NP435 Trans, Used With NP208 Transfer Case, Use 50WT Fluid	NP435-H	1990	1.6L	5 Spd, F5M22 Trans, CORE REQUIRED, REBUILD AND RETURN ONLY, Use 75W90	F5M22
8 CYL				1989	1.5L	5 Spd, KM201 Trans, CORE REQUIRED, REBUILD AND RETURN ONLY, Use 75W90	KM201
1975-79	5.2L, 5.9L, 6.6L, 7.2L	4x4, 4 Spd, NP435 Trans, Used With Divorced Transfer Cases, Use 50WT Fluid	NP435-J	1989	1.6L	5 Spd, KM206 Trans, CORE REQUIRED, REBUILD AND RETURN ONLY, Use 75W90	KM206
1975-79	5.2L, 5.9L, 6.6L, 7.2L	4x4, 4 Spd, NP435 Trans, Used With NP203 Or NP205 Transfer Case, Use 50WT Fluid	NP435-I	TALON			
1975-79	5.2L, 5.9L, 6.6L, 7.2L	4x4, 4 Spd, NP435 Trans, Used With NP208 Transfer Case, Use 50WT Fluid	NP435-H	4 CYL			
W350				1995-98	2.0L	5 Spd, All Aluminum Case, Cable Operated Clutch, Use MOPAR# 4874465 Fluid	A578-A
6 CYL				1995-98	2.0L	5 Spd, All Aluminum Case, Hydraulic Operated Clutch, Use MOPAR# 4874465 Fluid	A578-B
1989-93	5.9L	4x2, 5 Spd, Getrag 360, Press-In Speedo, 5W30 Used, Iron Case	G360-A	1993-94	1.8L	5 Spd, F5M22 Trans, CORE REQUIRED, REBUILD AND RETURN ONLY, Use 75W90	F5M22
1989-93	5.9L	4x4, 5 Spd, Getrag 360, No Speedo, 5W30 Used, Iron Case	G360-B	FORD			
8 CYL				"E-100, E-150 VAN"			
1992-93	5.9L	4x2, 5 Spd, NV4500 Trans, REBUILDABLE CORE REQUIRED, REBUILD AND RETURN ONLY, Use Dodge# 4637579 Fluid	NV4500-R	6 CYL			
1992-93	5.9L	4x4, 5 Spd, NV4500 Trans, REBUILDABLE CORE REQUIRED, REBUILD AND RETURN ONLY, Use Dodge# 4637579 Fluid	NV4500-O	1988-89	4.9L	4x2, 5 Spd, M5R2 Trans, No Speedo, ATF Used	M5R2-C
1982-83	5.2L	4x4, 4 Spd, NP435 Trans, Used With Divorced Transfer Cases, Use 50WT Fluid	NP435-J	1988-89	4.9L	4x2, 5 Spd, M5R2 Trans, Speedo- Green 8 Teeth, ATF Used	M5R2-B
1982-83	5.2L	4x4, 4 Spd, NP435 Trans, Used With NP208 Transfer Case, Use 50WT Fluid	NP435-H	1988-89	4.9L	4x2, 5 Spd, M5R2 Trans, Speedo- White 8 Teeth, ATF Used	M5R2-D
1981-91	5.2L, 5.9L	4x4, 4 Spd, NP435 Trans, Used With NP203 Or NP205 Transfer Case, Use 50WT Fluid	NP435-I	1988-89	4.9L	4x4, 5 Spd, M5R2 Trans, No Speedo, ATF Used	M5R2-A
1981-91	5.9L	4x2, 4 Spd, NP435 Trans, Cast Iron Tail Housing, Use 50WT Fluid	NP435-F	8 CYL			
EAGLE				1988-89	5.0L, 5.8L	4x2, 5 Spd, M5R2 Trans, No Speedo, ATF Used	M5R2-C
SUMMIT				1988-89	5.0L, 5.8L	4x2, 5 Spd, M5R2 Trans, Speedo- Green 8 Teeth, ATF Used	M5R2-B
4 CYL				1988-89	5.0L, 5.8L	4x2, 5 Spd, M5R2 Trans, Speedo- White 8 Teeth, ATF Used	M5R2-D
1993-94	1.5L	5 Spd, F5M21 Trans, CORE REQUIRED, REBUILD AND RETURN ONLY, Use 75W90	F5M21	1988-89	5.0L, 5.8L	4x4, 5 Spd, M5R2 Trans, No Speedo, ATF Used	M5R2-A
1992-94	1.8L, 2.4L	5 Spd, F5M22 Trans, CORE REQUIRED, REBUILD AND RETURN ONLY, Use 75W90	F5M22	"E-300, E-350 VAN"			
1992	1.5L	4 Spd, F4M21 Trans, CORE REQUIRED, REBUILD AND RETURN ONLY, Use 75W90	F4M21	6 CYL			
1990-91	1.5L	5 Spd, F5M21 Trans, CORE REQUIRED, REBUILD AND RETURN ONLY, Use 75W90	F5M21	1984-87	4.9L	4x2, 4 Spd, NP435 Trans, Bolt On Yoke, 28 Spline Main Shaft, Use 50WT Fluid	NP435-A
8 CYL				1984-87	4.9L	4x2, 4 Spd, NP435 Trans, Slip On Yoke, 31 Spline Main Shaft, Use 50WT Fluid	NP435-C
8 CYL				1984-87	4.9L	4x4, 4 Spd, NP435 Trans, Married Trans, Use 50WT Fluid	NP435-E
8 CYL				1984-87	5.8L, 6.9L, 7.5L	4x2, 4 Spd, NP435 Trans, Bolt On Yoke, 28 Spline Main Shaft, Use 50WT Fluid	NP435-A

Pro King Manual Transmissions

YEAR	ENGINE	APPLICATION	PART NO.	YEAR	ENGINE	APPLICATION	PART NO.
FORD (cont.)				FORD (cont.)			
"E-300, E-350 VAN" (cont.)				BRONCO & BRONCO II (cont.)			
8 CYL (cont.)				6 CYL (cont.)			
1984-87	5.8L, 6.9L, 7.5L	4x2, 4 Spd, NP435 Trans, Slip On Yoke, 31 Spline Main Shaft, Use 50WT Fluid	NP435-C	1988-92	4.9L	4x2, 5 Spd, M5R2 Trans, Speedo- White 8 Teeth, ATF Used	M5R2-D
1984-87	5.8L, 6.9L, 7.5L	4x4, 4 Spd, NP435 Trans, Married Trans, Use 50WT Fluid	NP435-E	1988-92	4.9L	4x4, 4 Spd, T18 Trans, Used With Married Transfer Case, Use 80W90	T18-C
AEROSTAR				1988-92	4.9L	4x4, 5 Spd, M5R2 Trans, No Speedo, ATF Used	M5R2-A
4 CYL				1980-87	4.9L	4x2, 4 Spd, NP435 Trans, Bolt On Yoke, 28 Spline Main Shaft, Use 50WT Fluid	NP435-A
1986-87	2.3L	4x2, 5 Spd, TK5 Trans, Beige Speedo Gear, Internal Slave Cylinder, Use SYNTHETIC 75W90	TK5-H	1980-87	4.9L	4x2, 4 Spd, NP435 Trans, Slip On Yoke, 31 Spline Main Shaft, Use 50WT Fluid	NP435-C
1986-87	2.3L	4x2, 5 Spd, TK5 Trans, Black Speedo Gear, Internal Slave Cylinder, Use SYNTHETIC 75W90	TK5-G	1980-87	4.9L	4x4, 4 Spd, NP435 Trans, Married Trans, Use 50WT Fluid	NP435-E
6 CYL				1980-85	4.9L	4x2, 4 Spd, T18 Trans, Slip Yolk Style, Cast# 13-01 On Case, Use 80W90	T18-B
1988-94	3.0L, 4.0L	4x2, 5 Spd, M5R1 Trans, Ext Speedo Drive, ATF Used, 3 Hole Starter Left Side	M5R1-F	1980-85	4.9L	4x4, 4 Spd, T18 Trans, Used With Married Transfer Case, Use 80W90	T18-C
1988-94	3.0L, 4.0L	4x2, 5 Spd, M5R1 Trans, No Speedo, ATF Used, 3 Hole Starter Left Side	M5R1-G	8 CYL			
1986-87	2.8L, 3.0L	4x2, 5 Spd, TK5 Trans, Beige Speedo Gear, Internal Slave Cylinder, Use SYNTHETIC 75W90	TK5-H	1989-92	5.0L, 5.8L	4x2, 5 Spd, S5-42 Trans, Covers ZF Tag Numbers 1307-050-034, -041 And -064, Use SYNTHETIC ATF	ZF-064
1986-87	2.8L, 3.0L	4x2, 5 Spd, TK5 Trans, Black Speedo Gear, Internal Slave Cylinder, Use SYNTHETIC 75W90	TK5-G	1989-92	5.0L, 5.8L	4x2, 5 Spd, S5-42, Covers ZF Tag Numbers 1307-050-012, -050, -068, -095 And -117, Use SYNTHETIC ATF	ZF-050
BRONCO & BRONCO II				1989-92	5.0L, 5.8L	4x2, 5 Spd, ZF S5-42, Covers ZF Tag Numbers 1307-050-039 And -051, Use SYNTHETIC ATF	ZF-051
6 CYL				1989-92	5.0L, 5.8L	4x4, 5 Spd, S5-42, Covers ZF Tag Numbers 1307-050-011, -052, -079, -096 And -118, Use SYNTHETIC ATF	ZF-118
1990	2.9L	4x2, 5 Spd, M5R1 Trans, No Speedo, ATF Used, 2 Hole Starter Left Side	M5R1-D	1988-96	5.0L, 5.8L	4x2, 5 Spd, M5R2 Trans, No Speedo, ATF Used	M5R2-C
1990	2.9L	4x2, 5 Spd, M5R1 Trans, Speedo- Purple 6 teeth, ATF Used, 2 Hole Starter Left Side	M5R1-C	1988-96	5.0L, 5.8L	4x2, 5 Spd, M5R2 Trans, Speedo- Green 8 Teeth, ATF Used	M5R2-B
1990	2.9L	4x2, 5 Spd, M5R1 Trans, Speedo- White 7 teeth, ATF Used, 2 Hole Starter Left Side	M5R1-E	1988-96	5.0L, 5.8L	4x2, 5 Spd, M5R2 Trans, M5R2-D Speedo- White 8 Teeth, ATF Used	M5R2-D
1990	2.9L	4x4, 5 Spd, M5R1 Trans, No Speedo, ATF Used, 2 Hole Starter Left Side, Use ATF	M5R1-B	1988-96	5.0L, 5.8L	4x4, 5 Spd, M5R2 Trans, No Speedo, ATF Used	M5R2-A
1989-92	4.9L	4x2, 5 Spd, S5-42 Trans, Covers ZF Tag Numbers 1307-050-034, -041 And -064, Use SYNTHETIC ATF	ZF-064	1988-92	5.0L, 5.8L	4x4, 4 Spd, T18 Trans, Used With Married Transfer Case, Use 80W90	T18-C
1989-92	4.9L	4x2, 5 Spd, S5-42, Covers ZF Tag Numbers 1307-050-012, -050, -068, -095 And -117, Use SYNTHETIC ATF	ZF-050	1980-85	5.0L, 5.8L	4x2, 4 Spd, T18 Trans, Slip Yolk Style, Cast# 13-01 On Case, Use 80W90	T18-B
1989-92	4.9L	4x2, 5 Spd, ZF S5-42, Covers ZF Tag Numbers 1307-050-039 And -051, Use SYNTHETIC ATF	ZF-051	1979-85	5.0L, 5.8L, 6.6L	4x4, 4 Spd, T18 Trans, Used With Married Transfer Case, Use 80W90	T18-C
1989-92	4.9L	4x4, 5 Spd, S5-42, Covers ZF Tag Numbers 1307-050-011, -052, -079, -096 And -118, Use SYNTHETIC ATF	ZF-118	1979	5.8L, 6.6L	4x2, 4 Spd, T18 Trans, Bolt On Yolk, Cast# 13-01 On Case, Use 80W90	T18-A
1988-92	4.9L	4x2, 5 Spd, M5R2 Trans, No Speedo, ATF Used	M5R2-C	1978-87	5.0L, 5.8L, 6.6L	4x2, 4 Spd, NP435 Trans, Bolt On Yoke, 28 Spline Main Shaft, Use 50WT Fluid	NP435-A
1988-92	4.9L	4x2, 5 Spd, M5R2 Trans, Speedo- Green 8 Teeth, ATF Used	M5R2-B	1978-87	5.0L, 5.8L, 6.6L	4x2, 4 Spd, NP435 Trans, Slip On Yoke, 31 Spline Main Shaft, Use 50WT Fluid	NP435-C

Pro King Manual Transmissions

YEAR	ENGINE	APPLICATION	PART NO.	YEAR	ENGINE	APPLICATION	PART NO.
FORD (cont.)				FORD (cont.)			
BRONCO & BRONCO II (cont.)				F SUPER DUTY (cont.)			
8 CYL (cont.)				8 CYL (cont.)			
1978-87	5.0L, 5.8L, 6.6L	4x4, 4 Spd, NP435 Trans, Married Trans, Use 50WT Fluid	NP435-E	1994-95	7.3L	4x2, 5 Spd, S5-42, Covers ZF Tag Numbers 1307-050-035, -038 And -057, Use SYNTHETIC ATF	ZF-057
ESCORT ZX2				8 CYL (cont.)			
4 CYL				8 CYL (cont.)			
2000	2.0L	5 Spd, M5TX Trans, CORE REQUIRED, REBUILD AND RETURN ONLY, Use ATF	M5TXA	1994-95	7.3L	4x4, 5 Spd, S5-42 Trans, Covers ZF Tag Numbers 1307-050-021, -032, -060, -082, -102 And 111ZW, Use SYNTHETIC ATF	ZF-111
EXPLORER				8 CYL (cont.)			
6 CYL				8 CYL (cont.)			
2005	4.0L	4x2, 5 Spd, M5R1 Trans, No Speedo, Use ATF	M5R1-DA	1994-95	7.3L	4x4, 5 Spd, S5-42, Covers ZF Tag Number 1307-050-058, No Speedo, 4.10 Axle 4.14-0.77 Ratio, Use SYNTHETIC ATF	ZF-109
2005	4.0L	4x2, 5 Spd, M5R1 Trans, With 6 Tooth Purple Speedo Gear, Use ATF	M5R1-CA	1994-95	7.5L	4x2, 5 Spd, S5-42, Covers ZF Tag Numbers 1307-050-014, -053, -069, -097 And -119, Use SYNTHETIC ATF	ZF-053
2005	4.0L	4x2, 5 Spd, M5R1, Speedo- White 7 teeth, ATF Used, One Switch on Top Cover	M5R1-EA	1994-95	7.5L	4x2, 5 Spd, S5-42, Covers ZF Tag Numbers 1307-050-040 And -054, Use SYNTHETIC ATF	ZF-054
2005	4.0L	4x4, 5 Spd, M5R1 Trans, With Speedo Sensor In Tail Housing, Use ATF	M5R1-BB	1994-95	7.5L	4x4, 5 Spd, S5-42, Covers ZF Tag Numbers 1307-050-003, -030, -042, -055, -080, -098 And -120, Use SYNTHETIC ATF	ZF-120
2001-03	4.0L	4x4, 5 Spd, M5R1 Trans, With Speedo Sensor In Tail Housing, Use ATF	M5R1-BB	1990	7.3L	4x2, 5 Spd, S5-42 Trans, Covers ZF Tag Numbers 1307-050-071, -101 And 110ZW, Use SYNTHETIC ATF	ZF-110
1995-03	4.0L	4x2, 5 Spd, M5R1 Trans, No Speedo, Use ATF	M5R1-DA	1990	7.3L	4x2, 5 Spd, S5-42, Covers ZF Tag Numbers 1307-050-004, -056, -070 And -099, Use SYNTHETIC ATF	ZF-056
1995-03	4.0L	4x2, 5 Spd, M5R1 Trans, With 6 Tooth Purple Speedo Gear, Use ATF	M5R1-CA	1990	7.3L	4x2, 5 Spd, S5-42, Covers ZF Tag Numbers 1307-050-022 And -059, Use SYNTHETIC ATF	ZF-057
1995-03	4.0L	4x2, 5 Spd, M5R1, Speedo- White 7 teeth, ATF Used, One Switch on Top Cover	M5R1-EA	1990	7.3L	4x2, 5 Spd, S5-42, Covers ZF Tag Numbers 1307-050-035, -038 And -057, Use SYNTHETIC ATF	ZF-111
1995-00	4.0L	4x4, 5 Spd, M5R1 Trans, Use ATF	M5R1-BA	1990	7.3L	4x4, 5 Spd, S5-42 Trans, Covers ZF Tag Numbers 1307-050-021, -032, -060, -082, -102 And 111ZW, Use SYNTHETIC ATF	ZF-111
1991-94	4.0L	4x2, 5 Spd, M5R1 Trans, No Speedo, ATF Used, 2 Hole Starter Left Side	M5R1-D	1990	7.3L	4x4, 5 Spd, S5-42, Covers ZF Tag Number 1307-050-058, No Speedo, 4.10 Axle 4.14-0.77 Ratio, Use SYNTHETIC ATF	ZF-109
1991-94	4.0L	4x2, 5 Spd, M5R1 Trans, Speedo- Purple 6 teeth, ATF Used, 2 Hole Starter Left Side	M5R1-C	1990	7.5L	4x2, 5 Spd, S5-42, Covers ZF Tag Numbers 1307-050-014, -053, -069, -097 And -119, Use SYNTHETIC ATF	ZF-053
1991-94	4.0L	4x2, 5 Spd, M5R1 Trans, Speedo- White 7 teeth, ATF Used, 2 Hole Starter Left Side	M5R1-E	1990	7.5L	4x2, 5 Spd, S5-42, Covers ZF Tag Numbers 1307-050-040 And -054, Use SYNTHETIC ATF	ZF-054
1991-94	4.0L	4x4, 5 Spd, M5R1 Trans, No Speedo, ATF Used, 2 Hole Starter Left Side, Use ATF	M5R1-B	1990	7.5L	4x4, 5 Spd, S5-42, Covers ZF Tag Numbers 1307-050-003, -030, -042, -055, -080, -098 And -120, Use SYNTHETIC ATF	ZF-120
F SUPER DUTY				8 CYL (cont.)			
8 CYL				8 CYL (cont.)			
1994-95	7.3L	4x2, 5 Spd, S5-42 Trans, Covers ZF Tag Numbers 1307-050-071, -101 And 110ZW, Use SYNTHETIC ATF	ZF-110	1990	7.3L	4x4, 5 Spd, S5-42, Covers ZF Tag Number 1307-050-058, No Speedo, 4.10 Axle 4.14-0.77 Ratio, Use SYNTHETIC ATF	ZF-109
1994-95	7.3L	4x2, 5 Spd, S5-42, Covers ZF Tag Number 1307-050-108ZW, Use SYNTHETIC ATF	ZF-108	1990	7.5L	4x2, 5 Spd, S5-42, Covers ZF Tag Numbers 1307-050-014, -053, -069, -097 And -119, Use SYNTHETIC ATF	ZF-053
1994-95	7.3L	4x2, 5 Spd, S5-42, Covers ZF Tag Numbers 1307-050-004, -056, -070 And -099, Use SYNTHETIC ATF	ZF-056	1990	7.5L	4x2, 5 Spd, S5-42, Covers ZF Tag Numbers 1307-050-040 And -054, Use SYNTHETIC ATF	ZF-054
1994-95	7.3L	4x2, 5 Spd, S5-42, Covers ZF Tag Numbers 1307-050-022 And -059, Use SYNTHETIC ATF	ZF-059	1990	7.5L	4x4, 5 Spd, S5-42, Covers ZF Tag Numbers 1307-050-003, -030, -042, -055, -080, -098 And -120, Use SYNTHETIC ATF	ZF-120

Pro King Manual Transmissions

YEAR	ENGINE	APPLICATION	PART NO.	YEAR	ENGINE	APPLICATION	PART NO.
FORD (cont.)				FORD (cont.)			
F-100				F-150 (cont.)			
6 CYL				6 CYL (cont.)			
1980-83	3.8L, 4.9L	4x2, 4 Spd, NP435 Trans, Bolt On Yoke, 28 Spline Main Shaft, Use 50WT Fluid	NP435-A	1997-98	4.2L	4x4, 5 Spd, M5R2 Trans, No Speedo, ATF Used, CORE REQUIRED, REBUILD AND RETURN ONLY	M5R2-E
1980-83	3.8L, 4.9L	4x2, 4 Spd, NP435 Trans, Slip On Yoke, 31 Spline Main Shaft, Use 50WT Fluid	NP435-C	1996	4.9L	4x2, 5 Spd, S5-47, Covers ZF Tag Number 1317-050-001, Use SYNTHETIC ATF	ZF-001
1980-83	3.8L, 4.9L	4x2, 4 Spd, T18 Trans, Slip Yolk Style, Cast# 13-01 On Case, Use 80W90	T18-B	1996	4.9L	4x4, 5 Spd, S5-47, Covers ZF Tag Number 1317-050-002, Use SYNTHETIC ATF	ZF-002
1980-83	3.8L, 4.9L	4x4, 4 Spd, NP435 Trans, Married Trans, Use 50WT Fluid	NP435-E	1988-96	4.9L	4x2, 5 Spd, M5R2 Trans, No Speedo, ATF Used	M5R2-C
1980-83	3.8L, 4.9L	4x4, 4 Spd, T18 Trans, Used With Married Transfer Case, Use 80W90	T18-C	1988-96	4.9L	4x2, 5 Spd, M5R2 Trans, Speedo- Green 8 Teeth, ATF Used	M5R2-B
1975	3.9L, 4.9L	4x2, 4 Spd, NP435 Trans, Bolt On Yoke, 28 Spline Main Shaft, Use 50WT Fluid	NP435-A	1988-96	4.9L	4x2, 5 Spd, M5R2 Trans, Speedo- White 8 Teeth, ATF Used	M5R2-D
1975	3.9L, 4.9L	4x2, 4 Spd, NP435 Trans, Slip On Yoke, 31 Spline Main Shaft, Use 50WT Fluid	NP435-C	1988-96	4.9L	4x2, 5 Spd, S5-42 Trans, Covers ZF Tag Numbers 1307-050-034, -041 And -064, Use SYNTHETIC ATF	ZF-064
1975	3.9L, 4.9L	4x2, 4 Spd, T18 Trans, Bolt On Yolk, Cast# 13-01 On Case, Use 80W90	T18-A	1988-96	4.9L	4x2, 5 Spd, S5-42, Covers ZF Tag Numbers 1307-050-012, -050, -068, -095 And -117, Use SYNTHETIC ATF	ZF-050
1975	3.9L, 4.9L	4x4, 4 Spd, NP435 Trans, Divorced Trans, Use 50WT Fluid	NP435-D	1988-96	4.9L	4x2, 5 Spd, ZF S5-42, Covers ZF Tag Numbers 1307-050-039 And -051, Use SYNTHETIC ATF	ZF-051
8 CYL				1988-96	4.9L	4x4, 5 Spd, M5R2 Trans, No Speedo, ATF Used	M5R2-A
1980-83	4.2L, 5.0L, 5.8L	4x2, 4 Spd, NP435 Trans, Bolt On Yoke, 28 Spline Main Shaft, Use 50WT Fluid	NP435-A	1988-96	4.9L	4x4, 5 Spd, S5-42, Covers ZF Tag Numbers 1307-050-011, -052, -079, -096 And -118, Use SYNTHETIC ATF	ZF-118
1980-83	4.2L, 5.0L, 5.8L	4x2, 4 Spd, NP435 Trans, Slip On Yoke, 31 Spline Main Shaft, Use 50WT Fluid	NP435-C	1987-94	4.9L	4x4, 4 Spd, T18 Trans, Used With Married Transfer Case, Use 80W90	T18-C
1980-83	4.2L, 5.0L, 5.8L	4x2, 4 Spd, T18 Trans, Slip Yolk Style, Cast# 13-01 On Case, Use 80W90	T18-B	1980-85	4.9L	4x2, 4 Spd, T18 Trans, Slip Yolk Style, Cast# 13-01 On Case, Use 80W90	T18-B
1980-83	4.2L, 5.0L, 5.8L	4x4, 4 Spd, NP435 Trans, Married Trans, Use 50WT Fluid	NP435-E	1977-86	4.9L	4x4, 4 Spd, NP435 Trans, Married Trans, Use 50WT Fluid	NP435-E
1980-83	4.2L, 5.0L, 5.8L	4x4, 4 Spd, T18 Trans, Used With Married Transfer Case, Use 80W90	T18-C	1977-85	4.9L	4x4, 4 Spd, T18 Trans, Used With Married Transfer Case, Use 80W90	T18-C
1975	5.0L, 5.9L, 6.4L, 7.5L	4x2, 4 Spd, NP435 Trans, Bolt On Yoke, 28 Spline Main Shaft, Use 50WT Fluid	NP435-A	1975-86	3.9L, 4.9L	4x2, 4 Spd, NP435 Trans, Bolt On Yoke, 28 Spline Main Shaft, Use 50WT Fluid	NP435-A
1975	5.0L, 5.9L, 6.4L, 7.5L	4x2, 4 Spd, NP435 Trans, Slip On Yoke, 31 Spline Main Shaft, Use 50WT Fluid	NP435-C	1975-86	3.9L, 4.9L	4x2, 4 Spd, NP435 Trans, Slip On Yoke, 31 Spline Main Shaft, Use 50WT Fluid	NP435-C
1975	5.0L, 5.9L, 6.4L, 7.5L	4x2, 4 Spd, T18 Trans, Bolt On Yolk, Cast# 13-01 On Case, Use 80W90	T18-A	1975-79	3.9L, 4.9L	4x2, 4 Spd, T18 Trans, Bolt On Yolk, Cast# 13-01 On Case, Use 80W90	T18-A
1975	5.0L, 5.9L, 6.4L, 7.5L	4x4, 4 Spd, NP435 Trans, Divorced Trans, Use 50WT Fluid	NP435-D	1975-77	3.9L, 4.9L	4x4, 4 Spd, NP435 Trans, Divorced Trans, Use 50WT Fluid	NP435-D
F-150				8 CYL			
6 CYL				1999-03	4.2L	4x2, 5 Spd, M5R2 Trans, CORE REQUIRED, REBUILD AND RETURN ONLY, Use ATF	M5R2-K
1999-03	4.2L	4x4, 5 Spd, M5R2 Trans, CORE REQUIRED, REBUILD AND RETURN ONLY, Use ATF	M5R2-I	1999-03	4.6L, 5.4L	4x2, 5 Spd, M5R2 Trans, CORE REQUIRED, REBUILD AND RETURN ONLY, Use ATF	M5R2-L
1997-98	4.2L	4x2, 5 Spd, M5R2 Trans, Speedo- Green 8 teeth, ATF Used, CORE REQUIRED, REBUILD AND RETURN ONLY	M5R2-G				

Pro King Manual Transmissions

YEAR	ENGINE	APPLICATION	PART NO.	YEAR	ENGINE	APPLICATION	PART NO.
FORD (cont.)				FORD (cont.)			
F-150 (cont.)				F-150 (cont.)			
8 CYL (cont.)				8 CYL (cont.)			
1999-03	4.6L, 5.4L	4x4, 5 Spd, M5R2 Trans, CORE REQUIRED, REBUILD AND RETURN ONLY, Speedo- White 7 teeth, ATF Used	M5R2-J	1975-86	5.0L, 5.8L, 5.9L, 6.4L, 6.6L, 6.9L, 7.5L	4x2, 4 Spd, NP435 Trans, Bolt On Yoke, 28 Spline Main Shaft, Use 50WT Fluid	NP435-A
1997-98	4.6L, 5.4L	4x2, 5 Spd, M5R2 Trans, Speedo- Green 8 Teeth, ATF Used, CORE REQUIRED, REBUILD AND RETURN ONLY	M5R2-H	1975-86	5.0L, 5.8L, 5.9L, 6.4L, 6.6L, 6.9L, 7.5L	4x2, 4 Spd, NP435 Trans, Slip On Yoke, 31 Spline Main Shaft, Use 50WT Fluid	NP435-C
1997-98	4.6L, 5.4L	4x4, 5 Spd, M5R2 Trans, No Speedo, ATF Used, CORE REQUIRED, REBUILD AND RETURN ONLY	M5R2-F	1975-79	5.0L, 5.8L, 5.9L, 6.4L, 6.6L, 7.5L	4x2, 4 Spd, T18 Trans, Bolt On Yolk, Cast# 13-01 On Case, Use 80W90	T18-A
1997	4.6L	4x2, 5 Spd, S5-47 Trans, Covers Tag Numbers 1317-050-014 And -016, Use SYNTHETIC ATF	ZF-016	1975-77	5.0L, 5.8L, 5.9L, 6.4L, 6.6L, 7.5L	4x4, 4 Spd, NP435 Trans, Divorced Trans, Use 50WT Fluid	NP435-D
1997	4.6L	4x4, 5 Spd, S5-47 Trans, Covers Tag Numbers 1317-050-008 And -015, Use SYNTHETIC ATF	ZF-015	F-150 HERITAGE			
1996-97	5.0L, 5.4L, 5.8L	4x2, 5 Spd, S5-47, Covers ZF Tag Number 1317-050-001, Use SYNTHETIC ATF	ZF-001	6 CYL			
1996-97	5.0L, 5.4L, 5.8L	4x4, 5 Spd, S5-47, Covers ZF Tag Number 1317-050-002, Use SYNTHETIC ATF	ZF-002	2004	4.2L	4x2, 5 Spd, M5R2 Trans, CORE REQUIRED, REBUILD AND RETURN ONLY, Use ATF	M5R2-K
1988-96	5.0L, 5.8L	4x2, 5 Spd, M5R2 Trans, No Speedo, ATF Used	M5R2-C	2004	4.2L	4x4, 5 Spd, M5R2 Trans, CORE REQUIRED, REBUILD AND RETURN ONLY, Use ATF	M5R2-I
1988-96	5.0L, 5.8L	4x2, 5 Spd, M5R2 Trans, Speedo- Green 8 Teeth, ATF Used	M5R2-B	8 CYL			
1988-96	5.0L, 5.8L	4x2, 5 Spd, M5R2 Trans, Speedo- White 8 Teeth, ATF Used	M5R2-D	2004	4.6L	4x2, 5 Spd, M5R2 Trans, CORE REQUIRED, REBUILD AND RETURN ONLY, Use ATF	M5R2-L
1988-96	5.0L, 5.8L	4x2, 5 Spd, S5-42 Trans, Covers ZF Tag Numbers 1307-050-034, -041 And -064, Use SYNTHETIC ATF	ZF-064	2004	4.6L	4x4, 5 Spd, M5R2 Trans, CORE REQUIRED, REBUILD AND RETURN ONLY, Speedo- White 7 teeth, ATF Used	M5R2-J
1988-96	5.0L, 5.8L	4x2, 5 Spd, S5-42, Covers ZF Tag Numbers 1307-050-012, -050, -068, -095 And -117, Use SYNTHETIC ATF	ZF-050	F-150 LIGHTNING			
1988-96	5.0L, 5.8L	4x2, 5 Spd, ZF S5-42, Covers ZF Tag Numbers 1307-050-039 And -051, Use SYNTHETIC ATF	ZF-051	8 CYL			
1988-96	5.0L, 5.8L	4x4, 5 Spd, M5R2 Trans, No Speedo, ATF Used	M5R2-A	1995	5.8L	4x2, 5 Spd, M5R2 Trans, No Speedo, ATF Used	M5R2-C
1988-96	5.0L, 5.8L	4x4, 5 Spd, S5-42, Covers ZF Tag Numbers 1307-050-011, -052, -079, -096 And -118, Use SYNTHETIC ATF	ZF-118	1995	5.8L	4x2, 5 Spd, M5R2 Trans, Speedo- Green 8 Teeth, ATF Used	M5R2-B
1987-94	5.0L, 5.8L	4x4, 4 Spd, T18 Trans, Used With Married Transfer Case, Use 80W90	T18-C	1995	5.8L	4x2, 5 Spd, M5R2 Trans, Speedo- White 8 Teeth, ATF Used	M5R2-D
1980-85	5.0L, 5.8L, 6.9L	4x2, 4 Spd, T18 Trans, Slip Yolk Style, Cast# 13-01 On Case, Use 80W90	T18-B	1995	5.8L	4x2, 5 Spd, S5-42 Trans, Covers ZF Tag Numbers 1307-050-034, -041 And -064, Use SYNTHETIC ATF	ZF-064
1977-86	5.0L, 5.8L, 6.6L, 6.9L, 7.5L	4x4, 4 Spd, NP435 Trans, Married Trans, Use 50WT Fluid	NP435-E	1995	5.8L	4x2, 5 Spd, S5-42, Covers ZF Tag Numbers 1307-050-012, -050, -068, -095 And -117, Use SYNTHETIC ATF	ZF-050
1977-85	5.0L, 5.8L, 6.6L, 6.9L, 7.5L	4x4, 4 Spd, T18 Trans, Used With Married Transfer Case, Use 80W90	T18-C	1995	5.8L	4x2, 5 Spd, ZF S5-42, Covers ZF Tag Numbers 1307-050-039 And -051, Use SYNTHETIC ATF	ZF-051
				1995	5.8L	4x4, 5 Spd, M5R2 Trans, No Speedo, ATF Used	M5R2-A
				1995	5.8L	4x4, 5 Spd, S5-42, Covers ZF Tag Numbers 1307-050-011, -052, -079, -096 And -118, Use SYNTHETIC ATF	ZF-118

Pro King Manual Transmissions

YEAR	ENGINE	APPLICATION	PART NO.	YEAR	ENGINE	APPLICATION	PART NO.
FORD (cont.)				FORD (cont.)			
F-150 SUPER CAB				F-150 SUPER CAB (cont.)			
6 CYL				8 CYL			
1997	4.2L	4x2, 5 Spd, M5R2 Trans, Speedo- Green 8 teeth, ATF Used, CORE REQUIRED, REBUILD AND RETURN ONLY	M5R2-G	1997-98	4.6L, 5.4L	4x2, 5 Spd, M5R2 Trans, Speedo- Green 8 Teeth, ATF Used, CORE REQUIRED, REBUILD AND RETURN ONLY	M5R2-H
1997	4.2L	4x4, 5 Spd, M5R2 Trans, No Speedo, ATF Used, CORE REQUIRED, REBUILD AND RETURN ONLY	M5R2-E	1997-98	4.6L, 5.4L	4x4, 5 Spd, M5R2 Trans, No Speedo, ATF Used, CORE REQUIRED, REBUILD AND RETURN ONLY	M5R2-F
1996	4.9L	4x2, 5 Spd, S5-47, Covers ZF Tag Number 1317-050-001, Use SYNTHETIC ATF	ZF-001	1997	4.6L	4x2, 5 Spd, S5-47 Trans, Covers Tag Numbers 1317-050-014 And -016, Use SYNTHETIC ATF	ZF-016
1996	4.9L	4x4, 5 Spd, S5-47, Covers ZF Tag Number 1317-050-002, Use SYNTHETIC ATF	ZF-002	1997	4.6L	4x4, 5 Spd, S5-47 Trans, Covers Tag Numbers 1317-050-008 And -015, Use SYNTHETIC ATF	ZF-015
1988-96	4.9L	4x2, 5 Spd, M5R2 Trans, No Speedo, ATF Used	M5R2-C	1996-97	5.0L, 5.4L, 5.8L	4x2, 5 Spd, S5-47, Covers ZF Tag Number 1317-050-001, Use SYNTHETIC ATF	ZF-001
1988-96	4.9L	4x2, 5 Spd, M5R2 Trans, Speedo- Green 8 Teeth, ATF Used	M5R2-B	1996-97	5.0L, 5.4L, 5.8L	4x4, 5 Spd, S5-47, Covers ZF Tag Number 1317-050-002, Use SYNTHETIC ATF	ZF-002
1988-96	4.9L	4x2, 5 Spd, M5R2 Trans, Speedo- White 8 Teeth, ATF Used	M5R2-D	1988-96	5.0L, 5.8L	4x2, 5 Spd, M5R2 Trans, No Speedo, ATF Used	M5R2-C
1988-96	4.9L	4x2, 5 Spd, S5-42 Trans, Covers ZF Tag Numbers 1307-050-034, -041 And -064, Use SYNTHETIC ATF	ZF-064	1988-96	5.0L, 5.8L	4x2, 5 Spd, M5R2 Trans, Speedo- Green 8 Teeth, ATF Used	M5R2-B
1988-96	4.9L	4x2, 5 Spd, S5-42, Covers ZF Tag Numbers 1307-050-012, -050, -068, -095 And -117, Use SYNTHETIC ATF	ZF-050	1988-96	5.0L, 5.8L	4x2, 5 Spd, M5R2 Trans, Speedo- White 8 Teeth, ATF Used	M5R2-D
1988-96	4.9L	4x2, 5 Spd, ZF S5-42, Covers ZF Tag Numbers 1307-050-039 And -051, Use SYNTHETIC ATF	ZF-051	1988-96	5.0L, 5.8L	4x2, 5 Spd, S5-42 Trans, Covers ZF Tag Numbers 1307-050-034, -041 And -064, Use SYNTHETIC ATF	ZF-064
1988-96	4.9L	4x4, 5 Spd, M5R2 Trans, No Speedo, ATF Used	M5R2-A	1988-96	5.0L, 5.8L	4x2, 5 Spd, S5-42, Covers ZF Tag Numbers 1307-050-012, -050, -068, -095 And -117, Use SYNTHETIC ATF	ZF-050
1988-96	4.9L	4x4, 5 Spd, S5-42, Covers ZF Tag Numbers 1307-050-011, -052, -079, -096 And -118, Use SYNTHETIC ATF	ZF-118	1988-96	5.0L, 5.8L	4x2, 5 Spd, ZF S5-42, Covers ZF Tag Numbers 1307-050-039 And -051, Use SYNTHETIC ATF	ZF-051
1987-94	4.9L	4x4, 4 Spd, T18 Trans, Used With Married Transfer Case, Use 80W90	T18-C	1988-96	5.0L, 5.8L	4x4, 5 Spd, M5R2 Trans, No Speedo, ATF Used	M5R2-A
1980-85	4.9L	4x2, 4 Spd, T18 Trans, Slip Yolk Style, Cast# 13-01 On Case, Use 80W90	T18-B	1988-96	5.0L, 5.8L	4x4, 5 Spd, S5-42, Covers ZF Tag Numbers 1307-050-011, -052, -079, -096 And -118, Use SYNTHETIC ATF	ZF-118
1977-86	4.9L	4x2, 4 Spd, NP435 Trans, Bolt On Yoke, 28 Spline Main Shaft, Use 50WT Fluid	NP435-A	1987-94	5.0L, 5.8L	4x4, 4 Spd, T18 Trans, Used With Married Transfer Case, Use 80W90	T18-C
1977-86	4.9L	4x2, 4 Spd, NP435 Trans, Slip On Yoke, 31 Spline Main Shaft, Use 50WT Fluid	NP435-C	1980-85	5.0L, 5.8L	4x2, 4 Spd, T18 Trans, Slip Yolk Style, Cast# 13-01 On Case, Use 80W90	T18-B
1977-86	4.9L	4x4, 4 Spd, NP435 Trans, Married Trans, Use 50WT Fluid	NP435-E	1977-86	5.0L, 5.8L, 6.6L, 7.5L	4x2, 4 Spd, NP435 Trans, Bolt On Yoke, 28 Spline Main Shaft, Use 50WT Fluid	NP435-A
1977-85	4.9L	4x4, 4 Spd, T18 Trans, Used With Married Transfer Case, Use 80W90	T18-C	1977-86	5.0L, 5.8L, 6.6L, 7.5L	4x2, 4 Spd, NP435 Trans, Slip On Yoke, 31 Spline Main Shaft, Use 50WT Fluid	NP435-C
1977-79	4.9L	4x2, 4 Spd, T18 Trans, Bolt On Yolk, Cast# 13-01 On Case, Use 80W90	T18-A	1977-86	5.0L, 5.8L, 6.6L, 7.5L	4x4, 4 Spd, NP435 Trans, Married Trans, Use 50WT Fluid	NP435-E
1977	4.9L	4x4, 4 Spd, NP435 Trans, Divorced Trans, Use 50WT Fluid	NP435-D	1977-85	5.0L, 5.8L, 6.6L, 7.5L	4x4, 4 Spd, T18 Trans, Used With Married Transfer Case, Use 80W90	T18-C

Pro King Manual Transmissions

YEAR	ENGINE	APPLICATION	PART NO.	YEAR	ENGINE	APPLICATION	PART NO.
FORD (cont.)				FORD (cont.)			
F-150 SUPER CAB (cont.)				F-250 (cont.)			
8 CYL (cont.)				6 CYL (cont.)			
1977-79	5.0L, 5.8L, 6.6L, 7.5L	4x2, 4 Spd, T18 Trans, Bolt On Yolk, Cast# 13-01 On Case, Use 80W90	T18-A	1975-87	4.9L	4x2, 4 Spd, NP435 Trans, Bolt On Yoke, 28 Spline Main Shaft, Use 50WT Fluid	NP435-A
1977	5.0L, 5.8L, 6.6L, 7.5L	4x4, 4 Spd, NP435 Trans, Divorced Trans, Use 50WT Fluid	NP435-D	1975-87	4.9L	4x2, 4 Spd, NP435 Trans, Slip On Yoke, 31 Spline Main Shaft, Use 50WT Fluid	NP435-C
F-250				8 CYL			
6 CYL				6 CYL (cont.)			
1996	4.9L	4x2, 5 Spd, M5R2 Trans, No Speedo, ATF Used	M5R2-C	1975-79	4.9L	4x2, 4 Spd, T18 Trans, Bolt On Yolk, Cast# 13-01 On Case, Use 80W90	T18-A
1996	4.9L	4x2, 5 Spd, M5R2 Trans, Speedo- Green 8 Teeth, ATF Used	M5R2-B	1975-77	4.9L	4x4, 4 Spd, NP435 Trans, Divorced Trans, Use 50WT Fluid	NP435-D
1996	4.9L	4x2, 5 Spd, M5R2 Trans, Speedo- White 8 Teeth, ATF Used	M5R2-D	8 CYL			
1996	4.9L	4x2, 5 Spd, S5-47, Covers ZF Tag Number 1317-050-001, Use SYNTHETIC ATF	ZF-001	1999	4.6L, 5.4L	4x2, 5 Spd, M5R2 Trans, CORE REQUIRED, REBUILD AND RETURN ONLY, Use ATF	M5R2-L
1996	4.9L	4x4, 5 Spd, M5R2 Trans, No Speedo, ATF Used	M5R2-A	1999	4.6L, 5.4L	4x4, 5 Spd, M5R2 Trans, CORE REQUIRED, REBUILD AND RETURN ONLY, Speedo- White 7 teeth, ATF Used	M5R2-J
1996	4.9L	4x4, 5 Spd, S5-47, Covers ZF Tag Number 1317-050-002, Use SYNTHETIC ATF	ZF-002	1997-98	4.6L, 5.4L, 5.8L, 7.5L	4x2, 5 Spd, M5R2 Trans, Speedo- Green 8 Teeth, ATF Used, CORE REQUIRED, REBUILD AND RETURN ONLY	M5R2-H
1988-94	4.9L	4x2, 5 Spd, M5R2 Trans, No Speedo, ATF Used	M5R2-C	1997-98	4.6L, 5.4L, 5.8L, 7.5L	4x4, 5 Spd, M5R2 Trans, No Speedo, ATF Used, CORE REQUIRED, REBUILD AND RETURN ONLY	M5R2-F
1988-94	4.9L	4x2, 5 Spd, M5R2 Trans, Speedo- Green 8 Teeth, ATF Used	M5R2-B	1997	4.6L	4x2, 5 Spd, S5-47 Trans, Covers Tag Numbers 1317-050-014 And -016, Use SYNTHETIC ATF	ZF-016
1988-94	4.9L	4x2, 5 Spd, M5R2 Trans, Speedo- White 8 Teeth, ATF Used	M5R2-D	1997	4.6L	4x4, 5 Spd, S5-47 Trans, Covers Tag Numbers 1317-050-008 And -015, Use SYNTHETIC ATF	ZF-015
1988-94	4.9L	4x4, 5 Spd, M5R2 Trans, No Speedo, ATF Used	M5R2-A	1996-97	5.0L, 5.4L, 5.8L	4x2, 5 Spd, S5-47, Covers ZF Tag Number 1317-050-001, Use SYNTHETIC ATF	ZF-001
1987-96	4.9L	4x2, 5 Spd, S5-42 Trans, Covers ZF Tag Numbers 1307-050-034, -041 And -064, Use SYNTHETIC ATF	ZF-064	1996-97	5.0L, 5.4L, 5.8L	4x4, 5 Spd, S5-47, Covers ZF Tag Number 1317-050-002, Use SYNTHETIC ATF	ZF-002
1987-96	4.9L	4x2, 5 Spd, S5-42, Covers ZF Tag Numbers 1307-050-012, -050, -068, -095 And -117, Use SYNTHETIC ATF	ZF-050	1996-97	7.3L	4x2, 5 Spd, S5-47, Covers ZF Tag Number 1317-050-003, Use SYNTHETIC ATF	ZF-003
1987-96	4.9L	4x2, 5 Spd, ZF S5-42, Covers ZF Tag Numbers 1307-050-039 And -051, Use SYNTHETIC ATF	ZF-051	1996-97	7.3L	4x4, 5 Spd, S5-47 Trans, Covers Tag Numbers 1317-050-004 And -012, Use SYNTHETIC ATF	ZF-012
1987-96	4.9L	4x4, 5 Spd, S5-42, Covers ZF Tag Numbers 1307-050-011, -052, -079, -096 And -118, Use SYNTHETIC ATF	ZF-118	1996-97	7.5L	4x2, 5 Spd, S5-47, Covers ZF Tag Number 1317-050-006, Use SYNTHETIC ATF	ZF-006
1983-87	4.9L	4x2, 4 Spd, T19 Trans, Speedo- Yellow 7T, Cast# 1309 On Case, Use 80W90	T19-A	1996-97	7.5L	4x4, 5 Spd, S5-47 Trans, Covers Tag Numbers 1317-050-007 And -013, Use SYNTHETIC ATF	ZF-013
1983-87	4.9L	4x4, 4 Spd, T19 Trans, Cast # 13-09 On Case, Use 80W90	T19-C	1996	5.0L, 5.8L, 7.5L	4x2, 5 Spd, M5R2 Trans, No Speedo, ATF Used	M5R2-C
1980-86	4.9L	4x2, 4 Spd, T18 Trans, Slip Yolk Style, Cast# 13-01 On Case, Use 80W90	T18-B	1996	5.0L, 5.8L, 7.5L	4x2, 5 Spd, M5R2 Trans, Speedo- Green 8 Teeth, ATF Used	M5R2-B
1977-94	4.9L	4x4, 4 Spd, T18 Trans, Used With Married Transfer Case, Use 80W90	T18-C	1996	5.0L, 5.8L, 7.5L	4x2, 5 Spd, M5R2 Trans, Speedo- White 8 Teeth, ATF Used	M5R2-D
1977-87	4.9L	4x4, 4 Spd, NP435 Trans, Married Trans, Use 50WT Fluid	NP435-E				

Pro King Manual Transmissions

YEAR	ENGINE	APPLICATION	PART NO.	YEAR	ENGINE	APPLICATION	PART NO.
FORD (cont.)				FORD (cont.)			
F-250 (cont.)				F-250 (cont.)			
8 CYL (cont.)				8 CYL (cont.)			
1996	5.0L, 5.8L, 7.5L	4x4, 5 Spd, M5R2 Trans, No Speedo, ATF Used	M5R2-A	1987-95	7.5L	4x4, 5 Spd, S5-42, Covers ZF Tag Numbers	ZF-120
1994-95	7.3L	4x2, 5 Spd, S5-42, Covers ZF Tag Number 1307-050-108ZW, Use SYNTHETIC ATF	ZF-108			1307-050-003, -030, -042, -055, -080, -098 And -120, Use SYNTHETIC ATF	
1988-94	5.0L, 5.8L, 7.5L	4x2, 5 Spd, M5R2 Trans, No Speedo, ATF Used	M5R2-C	1983-87	5.0L, 5.8L, 7.5L	4x2, 4 Spd, T19 Trans, Speedo- Yellow 7T, Cast# 1309 On Case, Use 80W90	T19-A
1988-94	5.0L, 5.8L, 7.5L	4x2, 5 Spd, M5R2 Trans, Speedo- Green 8 Teeth, ATF Used	M5R2-B	1983-87	5.0L, 5.8L, 7.5L	4x4, 4 Spd, T19 Trans, Cast # 13-09 On Case, Use 80W90	T19-C
1988-94	5.0L, 5.8L, 7.5L	4x2, 5 Spd, M5R2 Trans, Speedo- White 8 Teeth, ATF Used	M5R2-D	1983-87	6.9L	4x4, 4 Spd, T19 Trans, Cast # 13-09 On Case, Use 80W90	T19-D
1988-94	5.0L, 5.8L, 7.5L	4x4, 5 Spd, M5R2 Trans, No Speedo, ATF Used	M5R2-A	1983-87	6.9L	4x4, 4 Spd, T19 Trans, Speedo- Yellow 7T, Cast# 1309 On Case, Use 80W90	T19-B
1987-96	5.0L, 5.8L	4x2, 5 Spd, S5-42 Trans, Covers ZF Tag Numbers 1307-050-034, -041 And -064, Use SYNTHETIC ATF	ZF-064	1980-86	5.0L, 5.8L, 6.6L, 6.9L, 7.5L	4x2, 4 Spd, T18 Trans, Slip Yolk Style, Cast# 13-01 On Case, Use 80W90	T18-B
1987-96	5.0L, 5.8L	4x2, 5 Spd, S5-42, Covers ZF Tag Numbers 1307-050-012, -050, -068, -095 And -117, Use SYNTHETIC ATF	ZF-050	1977-94	5.0L, 5.8L, 6.6L, 6.9L, 7.3L, 7.5L	4x4, 4 Spd, T18 Trans, Used With Married Transfer Case, Use 80W90	T18-C
1987-96	5.0L, 5.8L	4x2, 5 Spd, ZF S5-42, Covers ZF Tag Numbers 1307-050-039 And -051, Use SYNTHETIC ATF	ZF-051	1977-87	5.0L, 5.8L, 6.6L, 6.9L, 7.5L	4x4, 4 Spd, NP435 Trans, Married Trans, Use 50WT Fluid	NP435-E
1987-96	5.0L, 5.8L	4x4, 5 Spd, S5-42, Covers ZF Tag Numbers 1307-050-011, -052, -079, -096 And -118, Use SYNTHETIC ATF	ZF-118	1975-87	5.0L, 5.8L, 5.9L, 6.4L, 6.6L, 6.9L, 7.5L	4x2, 4 Spd, NP435 Trans, Bolt On Yoke, 28 Spline Main Shaft, Use 50WT Fluid	NP435-A
1987-95	6.9L, 7.3L	4x2, 5 Spd, S5-42 Trans, Covers ZF Tag Numbers 1307-050-071, -101 And 110ZW, Use SYNTHETIC ATF	ZF-110	1975-87	5.0L, 5.8L, 5.9L, 6.4L, 6.6L, 6.9L, 7.5L	4x2, 4 Spd, NP435 Trans, Slip On Yoke, 31 Spline Main Shaft, Use 50WT Fluid	NP435-C
1987-95	6.9L, 7.3L	4x2, 5 Spd, S5-42, Covers ZF Tag Numbers 1307-050-004, -056, -070 And -099, Use SYNTHETIC ATF	ZF-056	1975-79	5.0L, 5.8L, 5.9L, 6.4L, 6.6L, 7.5L	4x2, 4 Spd, T18 Trans, Bolt On Yolk, Cast# 13-01 On Case, Use 80W90	T18-A
1987-95	6.9L, 7.3L	4x2, 5 Spd, S5-42, Covers ZF Tag Numbers 1307-050-022 And -059, Use SYNTHETIC ATF	ZF-059	1975-77	5.0L, 5.8L, 5.9L, 6.4L, 6.6L, 7.5L	4x4, 4 Spd, NP435 Trans, Divorced Trans, Use 50WT Fluid	NP435-D
1987-95	6.9L, 7.3L	4x2, 5 Spd, S5-42, Covers ZF Tag Numbers 1307-050-035, -038 And -057, Use SYNTHETIC ATF	ZF-057	F-250 PICKUP			
1987-95	6.9L, 7.3L	4x4, 5 Spd, S5-42 Trans, Covers ZF Tag Numbers 1307-050-021, -032, -060, -082, -102 And 111ZW, Use SYNTHETIC ATF	ZF-111	8 CYL			
1987-95	6.9L, 7.3L	4x4, 5 Spd, S5-42, Covers ZF Tag Number 1307-050-058, No Speedo, 4.10 Axle 4.14-0.77 Ratio, Use SYNTHETIC ATF	ZF-109	2006	6.0L	4x2, 6 Spd, 6S-750 Trans, Use SYNTHETIC ATF	ZF-704
1987-95	7.5L	4x2, 5 Spd, S5-42, Covers ZF Tag Numbers 1307-050-014, -053, -069, -097 And -119, Use SYNTHETIC ATF	ZF-053	2006	6.0L	4x4, 6 Spd, 6S-750 Trans, Use SYNTHETIC ATF	ZF-705
1987-95	7.5L	4x2, 5 Spd, S5-42, Covers ZF Tag Numbers 1307-050-040 And -054, Use SYNTHETIC ATF	ZF-054	10 CYL			
				2006	6.8L	4x4, 6 Spd, S6-650 Trans, Covers ZF Tag Number 1319-050-044, Use SYNTHETIC ATF	ZF-644
				F-250 SUPER CAB			
				6 CYL			
				1990-95	4.9L	4x2, 5 Spd, S5-42 Trans, Covers ZF Tag Numbers 1307-050-034, -041 And -064, Use SYNTHETIC ATF	ZF-064
				1990-95	4.9L	4x2, 5 Spd, S5-42, Covers ZF Tag Numbers 1307-050-012, -050, -068, -095 And -117, Use SYNTHETIC ATF	ZF-050
				1990-95	4.9L	4x2, 5 Spd, ZF S5-42, Covers ZF Tag Numbers 1307-050-039 And -051, Use SYNTHETIC ATF	ZF-051
				1990-95	4.9L	4x4, 5 Spd, S5-42, Covers ZF Tag Numbers 1307-050-011, -052, -079, -096 And -118, Use SYNTHETIC ATF	ZF-118

Pro King Manual Transmissions

YEAR	ENGINE	APPLICATION	PART NO.	YEAR	ENGINE	APPLICATION	PART NO.
FORD (cont.)				FORD (cont.)			
F-250 SUPER CAB (cont.)				F-250 SUPER CAB (cont.)			
6 CYL (cont.)				8 CYL			
1990-94	4.9L	4x2, 5 Spd, M5R2 Trans, No Speedo, ATF Used	M5R2-C	1999	4.6L, 5.4L	4x2, 5 Spd, M5R2 Trans, CORE REQUIRED, REBUILD AND RETURN ONLY, Use ATF	M5R2-L
1990-94	4.9L	4x2, 5 Spd, M5R2 Trans, Speedo- Green 8 Teeth, ATF Used	M5R2-B	1999	4.6L, 5.4L	4x4, 5 Spd, M5R2 Trans, CORE REQUIRED, REBUILD AND RETURN ONLY, Speedo- White 7 teeth, ATF Used	M5R2-J
1990-94	4.9L	4x2, 5 Spd, M5R2 Trans, Speedo- White 8 Teeth, ATF Used	M5R2-D	1997-98	4.6L, 5.4L, 5.8L, 7.5L	4x2, 5 Spd, M5R2 Trans, Speedo- Green 8 Teeth, ATF Used, CORE REQUIRED, REBUILD AND RETURN ONLY	M5R2-H
1990-94	4.9L	4x4, 4 Spd, T18 Trans, Used With Married Transfer Case, Use 80W90	T18-C	1997-98	4.6L, 5.4L, 5.8L, 7.5L	4x4, 5 Spd, M5R2 Trans, No Speedo, ATF Used, CORE REQUIRED, REBUILD AND RETURN ONLY	M5R2-F
1990-94	4.9L	4x4, 5 Spd, M5R2 Trans, No Speedo, ATF Used	M5R2-A	1997	4.6L	4x2, 5 Spd, S5-47 Trans, Covers Tag Numbers 1317-050-014 And -016 , Use SYNTHETIC ATF	ZF-016
1988	4.9L	4x2, 5 Spd, M5R2 Trans, No Speedo, ATF Used	M5R2-C	1997	4.6L	4x4, 5 Spd, S5-47 Trans, Covers Tag Numbers 1317-050-008 And -015 , Use SYNTHETIC ATF	ZF-015
1988	4.9L	4x2, 5 Spd, M5R2 Trans, Speedo- Green 8 Teeth, ATF Used	M5R2-B	1996-97	5.4L, 5.8L	4x2, 5 Spd, S5-47, Covers ZF Tag Number 1317-050-001, Use SYNTHETIC ATF	ZF-001
1988	4.9L	4x2, 5 Spd, M5R2 Trans, Speedo- White 8 Teeth, ATF Used	M5R2-D	1996-97	5.4L, 5.8L	4x4, 5 Spd, S5-47, Covers ZF Tag Number 1317-050-002, Use SYNTHETIC ATF	ZF-002
1988	4.9L	4x4, 5 Spd, M5R2 Trans, No Speedo, ATF Used	M5R2-A	1996-97	7.3L	4x2, 5 Spd, S5-47, Covers ZF Tag Number 1317-050-003, Use SYNTHETIC ATF	ZF-003
1987-88	4.9L	4x2, 5 Spd, S5-42 Trans, Covers ZF Tag Numbers 1307-050-034, -041 And -064, Use SYNTHETIC ATF	ZF-064	1996-97	7.3L	4x4, 5 Spd, S5-47 Trans, Covers Tag Numbers 1317-050-004 And -012, Use SYNTHETIC ATF	ZF-012
1987-88	4.9L	4x2, 5 Spd, S5-42, Covers ZF Tag Numbers 1307-050-012, -050, -068, -095 And -117, Use SYNTHETIC ATF	ZF-050	1996-97	7.5L	4x2, 5 Spd, S5-47, Covers ZF Tag Number 1317-050-006, Use SYNTHETIC ATF	ZF-006
1987-88	4.9L	4x2, 5 Spd, ZF S5-42, Covers ZF Tag Numbers 1307-050-039 And -051, Use SYNTHETIC ATF	ZF-051	1996-97	7.5L	4x4, 5 Spd, S5-47 Trans, Covers Tag Numbers 1317-050-007 And -013 , Use SYNTHETIC ATF	ZF-013
1987-88	4.9L	4x4, 5 Spd, S5-42, Covers ZF Tag Numbers 1307-050-011, -052, -079, -096 And -118, Use SYNTHETIC ATF	ZF-118	1996	5.8L, 7.5L	4x2, 5 Spd, M5R2 Trans, No Speedo, ATF Used	M5R2-C
1983-87	4.9L	4x2, 4 Spd, T19 Trans, Speedo- Yellow 7T, Cast# 1309 On Case, Use 80W90	T19-A	1996	5.8L, 7.5L	4x2, 5 Spd, M5R2 Trans, Speedo- Green 8 Teeth, ATF Used	M5R2-B
1983-87	4.9L	4x4, 4 Spd, T19 Trans, Cast # 13-09 On Case, Use 80W90	T19-C	1996	5.8L, 7.5L	4x2, 5 Spd, M5R2 Trans, Speedo- White 8 Teeth, ATF Used	M5R2-D
1980-86	4.9L	4x2, 4 Spd, T18 Trans, Slip Yolk Style, Cast# 13-01 On Case, Use 80W90	T18-B	1996	5.8L, 7.5L	4x4, 5 Spd, M5R2 Trans, No Speedo, ATF Used	M5R2-A
1977-88	4.9L	4x4, 4 Spd, T18 Trans, Used With Married Transfer Case, Use 80W90	T18-C	1994-95	7.3L	4x2, 5 Spd, S5-42, Covers ZF Tag Number 1307-050-108ZW, Use SYNTHETIC ATF	ZF-108
1977-87	4.9L	4x2, 4 Spd, NP435 Trans, Bolt On Yoke, 28 Spline Main Shaft, Use 50WT Fluid	NP435-A	1988-94	5.8L, 7.5L	4x2, 5 Spd, M5R2 Trans, No Speedo, ATF Used	M5R2-C
1977-87	4.9L	4x2, 4 Spd, NP435 Trans, Slip On Yoke, 31 Spline Main Shaft, Use 50WT Fluid	NP435-C	1988-94	5.8L, 7.5L	4x2, 5 Spd, M5R2 Trans, Speedo- Green 8 Teeth, ATF Used	M5R2-B
1977-87	4.9L	4x4, 4 Spd, NP435 Trans, Married Trans, Use 50WT Fluid	NP435-E	1988-94	5.8L, 7.5L	4x2, 5 Spd, M5R2 Trans, Speedo- White 8 Teeth, ATF Used	M5R2-D
1977-79	4.9L	4x2, 4 Spd, T18 Trans, Bolt On Yolk, Cast# 13-01 On Case, Use 80W90	T18-A				
1977	4.9L	4x4, 4 Spd, NP435 Trans, Divorced Trans, Use 50WT Fluid	NP435-D				

Pro King Manual Transmissions

YEAR	ENGINE	APPLICATION	PART NO.	YEAR	ENGINE	APPLICATION	PART NO.
FORD (cont.)				FORD (cont.)			
F-250 SUPER CAB (cont.)				F-250 SUPER CAB (cont.)			
8 CYL (cont.)				8 CYL (cont.)			
1988-94	5.8L, 7.5L	4x4, 5 Spd, M5R2 Trans, No Speedo, ATF Used	M5R2-A	1983-87	6.9L	4x4, 4 Spd, T19 Trans, Speedo- Yellow 7T, Cast# 1309 On Case, Use 80W90	T19-B
1987-96	5.8L	4x2, 5 Spd, S5-42 Trans, Covers ZF Tag Numbers 1307-050-034, -041 And -064, Use SYNTHETIC ATF	ZF-064	1980-86	5.0L, 5.8L, 6.6L, 6.9L, 7.5L	4x2, 4 Spd, T18 Trans, Slip Yolk Style, Cast# 13-01 On Case, Use 80W90	T18-B
1987-96	5.8L	4x2, 5 Spd, S5-42, Covers ZF Tag Numbers 1307-050-012, -050, -068, -095 And -117, Use SYNTHETIC ATF	ZF-050	1977-94	5.0L, 5.8L, 6.6L, 6.9L, 7.3L, 7.5L	4x4, 4 Spd, T18 Trans, Used With Married Transfer Case, Use 80W90	T18-C
1987-96	5.8L	4x2, 5 Spd, ZF S5-42, Covers ZF Tag Numbers 1307-050-039 And -051, Use SYNTHETIC ATF	ZF-051	1977-87	5.0L, 5.8L, 6.6L, 6.9L, 7.5L	4x2, 4 Spd, NP435 Trans, Bolt On Yoke, 28 Spline Main Shaft, Use 50WT Fluid	NP435-A
1987-96	5.8L	4x4, 5 Spd, S5-42, Covers ZF Tag Numbers 1307-050-011, -052, -079, -096 And -118, Use SYNTHETIC ATF	ZF-118	1977-87	5.0L, 5.8L, 6.6L, 6.9L, 7.5L	4x2, 4 Spd, NP435 Trans, Slip On Yoke, 31 Spline Main Shaft, Use 50WT Fluid	NP435-C
1987-95	6.9L, 7.3L	4x2, 5 Spd, S5-42 Trans, Covers ZF Tag Numbers 1307-050-071, -101 And 110ZW, Use SYNTHETIC ATF	ZF-110	1977-87	5.0L, 5.8L, 6.6L, 6.9L, 7.5L	4x4, 4 Spd, NP435 Trans, Married Trans, Use 50WT Fluid	NP435-E
1987-95	6.9L, 7.3L	4x2, 5 Spd, S5-42, Covers ZF Tag Numbers 1307-050-004, -056, -070 And -099, Use SYNTHETIC ATF	ZF-056	1977-79	5.0L, 5.8L, 6.6L, 7.5L	4x2, 4 Spd, T18 Trans, Bolt On Yolk, Cast# 13-01 On Case, Use 80W90	T18-A
1987-95	6.9L, 7.3L	4x2, 5 Spd, S5-42, Covers ZF Tag Numbers 1307-050-022 And -059, Use SYNTHETIC ATF	ZF-059	1977	5.0L, 5.8L, 6.6L, 7.5L	4x4, 4 Spd, NP435 Trans, Divorced Trans, Use 50WT Fluid	NP435-D
1987-95	6.9L, 7.3L	4x2, 5 Spd, S5-42, Covers ZF Tag Numbers 1307-050-035, -038 And -057, Use SYNTHETIC ATF	ZF-057	F-250 SUPER DUTY			
1987-95	6.9L, 7.3L	4x4, 5 Spd, S5-42 Trans, Covers ZF Tag Numbers 1307-050-021, -032, -060, -082, -102 And 111ZW, Use SYNTHETIC ATF	ZF-111	8 CYL			
1987-95	6.9L, 7.3L	4x4, 5 Spd, S5-42, Covers ZF Tag Number 1307-050-058, No Speedo, 4.10 Axle 4.14-0.77 Ratio, Use SYNTHETIC ATF	ZF-109	2003-05	6.0L	4x2, 6 Spd, 6S-750 Trans, Use SYNTHETIC ATF	ZF-704
1987-95	7.5L	4x2, 5 Spd, S5-42, Covers ZF Tag Numbers 1307-050-014, -053, -069, -097 And -119, Use SYNTHETIC ATF	ZF-053	2003-05	6.0L	4x4, 6 Spd, 6S-750 Trans, Use SYNTHETIC ATF	ZF-705
1987-95	7.5L	4x2, 5 Spd, S5-42, Covers ZF Tag Numbers 1307-050-040 And -054, Use SYNTHETIC ATF	ZF-054	2001-03	7.3L	4x2, 6 Spd, S6-650 Trans, Use SYNTHETIC ATF	ZF-624
1987-95	7.5L	4x4, 5 Spd, S5-42, Covers ZF Tag Numbers 1307-050-003, -030, -042, -055, -080, -098 And -120, Use SYNTHETIC ATF	ZF-120	2001-02	7.3L	4x4, 6 Spd, S6-650 Trans, Use SYNTHETIC ATF	ZF-625
1983-87	5.0L, 5.8L, 7.5L	4x2, 4 Spd, T19 Trans, Speedo- Yellow 7T, Cast# 1309 On Case, Use 80W90	T19-A	1999-02	5.4L	4x2, 5 Spd, S5-47, Covers ZF Tag Number 1317-050-001, Use SYNTHETIC ATF	ZF-001
1983-87	5.0L, 5.8L, 7.5L	4x4, 4 Spd, T19 Trans, Cast # 13-09 On Case, Use 80W90	T19-C	1999-02	5.4L	4x4, 5 Spd, S5-47, Covers ZF Tag Number 1317-050-002, Use SYNTHETIC ATF	ZF-002
1983-87	6.9L	4x4, 4 Spd, T19 Trans, Cast # 13-09 On Case, Use 80W90	T19-D	1999-02	7.3L	4x2, 5 Spd, S5-47, Covers ZF Tag Number 1317-050-003, Use SYNTHETIC ATF	ZF-003
				10 CYL			
				F-350			
				6 CYL			
				2002-05	6.8L	4x4, 6 Spd, S6-650 Trans, Covers ZF Tag Number 1319-050-044, Use SYNTHETIC ATF	ZF-644
				F-350			
				6 CYL			
				1996	4.9L	4x2, 5 Spd, S5-47, Covers ZF Tag Number 1317-050-001, Use SYNTHETIC ATF	ZF-001

Pro King Manual Transmissions

YEAR	ENGINE	APPLICATION	PART NO.	YEAR	ENGINE	APPLICATION	PART NO.
FORD (cont.)				FORD (cont.)			
F-350 (cont.)				F-350 (cont.)			
6 CYL (cont.)				8 CYL			
1996	4.9L	4x4, 5 Spd, S5-47, Covers ZF Tag Number 1317-050-002, Use SYNTHETIC ATF	ZF-002	1996-97	5.8L	4x2, 5 Spd, S5-47, Covers ZF Tag Number 1317-050-001, Use SYNTHETIC ATF	ZF-001
1990-92	4.9L	4x2, 5 Spd, M5R2 Trans, No Speedo, ATF Used	M5R2-C	1996-97	5.8L	4x4, 5 Spd, S5-47, Covers ZF Tag Number 1317-050-002, Use SYNTHETIC ATF	ZF-002
1990-92	4.9L	4x2, 5 Spd, M5R2 Trans, Speedo- Green 8 Teeth, ATF Used	M5R2-B	1996-97	7.3L	4x2, 5 Spd, S5-47, Covers ZF Tag Number 1317-050-003, Use SYNTHETIC ATF	ZF-003
1990-92	4.9L	4x2, 5 Spd, M5R2 Trans, Speedo- White 8 Teeth, ATF Used	M5R2-D	1996-97	7.3L	4x4, 5 Spd, S5-47 Trans, Covers Tag Numbers 1317-050-004 And -012, Use SYNTHETIC ATF	ZF-012
1990-92	4.9L	4x4, 4 Spd, T18 Trans, Used With Married Transfer Case, Use 80W90	T18-C	1996-97	7.5L	4x2, 5 Spd, S5-47, Covers ZF Tag Number 1317-050-006, Use SYNTHETIC ATF	ZF-006
1990-92	4.9L	4x4, 5 Spd, M5R2 Trans, No Speedo, ATF Used	M5R2-A	1996-97	7.5L	4x4, 5 Spd, S5-47 Trans, Covers Tag Numbers 1317-050-007 And -013 , Use SYNTHETIC ATF	ZF-013
1987-96	4.9L	4x2, 5 Spd, S5-42 Trans, Covers ZF Tag Numbers 1307-050-034, -041 And -064, Use SYNTHETIC ATF	ZF-064	1994-95	7.3L	4x2, 5 Spd, S5-42, Covers ZF Tag Number 1307-050-108ZW, Use SYNTHETIC ATF	ZF-108
1987-96	4.9L	4x2, 5 Spd, S5-42, Covers ZF Tag Numbers 1307-050-012, -050, -068, -095 And -117, Use SYNTHETIC ATF	ZF-050	1990-92	5.8L, 7.3L, 7.5L	4x4, 4 Spd, T18 Trans, Used With Married Transfer Case, Use 80W90	T18-C
1987-96	4.9L	4x2, 5 Spd, ZF S5-42, Covers ZF Tag Numbers 1307-050-039 And -051, Use SYNTHETIC ATF	ZF-051	1990-92	5.8L, 7.5L	4x2, 5 Spd, M5R2 Trans, No Speedo, ATF Used	M5R2-C
1987-96	4.9L	4x4, 5 Spd, S5-42, Covers ZF Tag Numbers 1307-050-011, -052, -079, -096 And -118, Use SYNTHETIC ATF	ZF-118	1990-92	5.8L, 7.5L	4x2, 5 Spd, M5R2 Trans, Speedo- Green 8 Teeth, ATF Used	M5R2-B
1983-87	4.9L	4x2, 4 Spd, T19 Trans, Speedo- Yellow 7T, Cast# 1309 On Case, Use 80W90	T19-A	1990-92	5.8L, 7.5L	4x2, 5 Spd, M5R2 Trans, Speedo- White 8 Teeth, ATF Used	M5R2-D
1983-87	4.9L	4x4, 4 Spd, T19 Trans, Cast # 13-09 On Case, Use 80W90	T19-C	1990-92	5.8L, 7.5L	4x4, 5 Spd, M5R2 Trans, No Speedo, ATF Used	M5R2-A
1980-86	4.9L	4x2, 4 Spd, T18 Trans, Slip Yolk Style, Cast# 13-01 On Case, Use 80W90	T18-B	1987-96	5.8L	4x2, 5 Spd, S5-42 Trans, Covers ZF Tag Numbers 1307-050-034, -041 And -064, Use SYNTHETIC ATF	ZF-064
1977-88	4.9L	4x4, 4 Spd, T18 Trans, Used With Married Transfer Case, Use 80W90	T18-C	1987-96	5.8L	4x2, 5 Spd, S5-42, Covers ZF Tag Numbers 1307-050-012, -050, -068, -095 And -117, Use SYNTHETIC ATF	ZF-050
1977-87	4.9L	4x4, 4 Spd, NP435 Trans, Married Trans, Use 50WT Fluid	NP435-E	1987-96	5.8L	4x2, 5 Spd, ZF S5-42, Covers ZF Tag Numbers 1307-050-039 And -051, Use SYNTHETIC ATF	ZF-051
1975-87	4.9L	4x2, 4 Spd, NP435 Trans, Bolt On Yoke, 28 Spline Main Shaft, Use 50WT Fluid	NP435-A	1987-96	5.8L	4x4, 5 Spd, S5-42, Covers ZF Tag Numbers 1307-050-011, -052, -079, -096 And -118, Use SYNTHETIC ATF	ZF-118
1975-87	4.9L	4x2, 4 Spd, NP435 Trans, Slip On Yoke, 31 Spline Main Shaft, Use 50WT Fluid	NP435-C	1987-95	6.9L, 7.3L	4x2, 5 Spd, S5-42 Trans, Covers ZF Tag Numbers 1307-050-071, -101 And 110ZW, Use SYNTHETIC ATF	ZF-110
1975-79	4.9L	4x2, 4 Spd, T18 Trans, Bolt On Yolk, Cast# 13-01 On Case, Use 80W90	T18-A	1987-95	6.9L, 7.3L	4x2, 5 Spd, S5-42, Covers ZF Tag Numbers 1307-050-004, -056, -070 And -099, Use SYNTHETIC ATF	ZF-056
1975-79	4.9L	4x2, 4 Spd, T19 Trans, Speedo- Yellow 7T, Cast# 1309 On Case, Use 80W90	T19-A				
1975-79	4.9L	4x4, 4 Spd, T19 Trans, Cast # 13-09 On Case, Use 80W90	T19-C				
1975-77	4.9L	4x4, 4 Spd, NP435 Trans, Divorced Trans, Use 50WT Fluid	NP435-D				

Pro King Manual Transmissions

YEAR	ENGINE	APPLICATION	PART NO.	YEAR	ENGINE	APPLICATION	PART NO.
FORD (cont.)				FORD (cont.)			
F-350 (cont.)				F-350 PICKUP			
8 CYL (cont.)				8 CYL			
1987-95	6.9L, 7.3L	4x2, 5 Spd, S5-42, Covers ZF Tag Numbers 1307-050-022 And -059, Use SYNTHETIC ATF	ZF-059	2006	6.0L	4x2, 6 Spd, 6S-750 Trans, Use SYNTHETIC ATF	ZF-704
1987-95	6.9L, 7.3L	4x2, 5 Spd, S5-42, Covers ZF Tag Numbers 1307-050-035, -038 And -057, Use SYNTHETIC ATF	ZF-057	2006	6.0L	4x4, 6 Spd, 6S-750 Trans, Use SYNTHETIC ATF	ZF-705
1987-95	6.9L, 7.3L	4x4, 5 Spd, S5-42 Trans, Covers ZF Tag Numbers 1307-050-021, -032, -060, -082, -102 And 111ZW, Use SYNTHETIC ATF	ZF-111	10 CYL			
1987-95	6.9L, 7.3L	4x4, 5 Spd, S5-42, Covers ZF Tag Number 1307-050-058, No Speedo, 4.10 Axle 4.14-0.77 Ratio, Use SYNTHETIC ATF	ZF-109	2006	6.8L	4x4, 6 Spd, S6-650 Trans, Covers ZF Tag Number 1319-050-044, Use SYNTHETIC ATF	ZF-644
1987-95	7.5L	4x2, 5 Spd, S5-42, Covers ZF Tag Numbers 1307-050-014, -053, -069, -097 And -119, Use SYNTHETIC ATF	ZF-053	F-350 SUPER CAB			
1987-95	7.5L	4x2, 5 Spd, S5-42, Covers ZF Tag Numbers 1307-050-040 And -054, Use SYNTHETIC ATF	ZF-054	6 CYL			
1987-95	7.5L	4x4, 5 Spd, S5-42, Covers ZF Tag Numbers 1307-050-003, -030, -042, -055, -080, -098 And -120, Use SYNTHETIC ATF	ZF-120	1980	4.9L	4x2, 4 Spd, T18 Trans, Slip Yolk Style, Cast# 13-01 On Case, Use 80W90	T18-B
1983-87	5.8L, 7.5L	4x2, 4 Spd, T19 Trans, Speedo- Yellow 7T, Cast# 1309 On Case, Use 80W90	T19-A	1979-80	4.9L	4x2, 4 Spd, NP435 Trans, Bolt On Yoke, 28 Spline Main Shaft, Use 50WT Fluid	NP435-A
1983-87	5.8L, 7.5L	4x4, 4 Spd, T19 Trans, Cast # 13-09 On Case, Use 80W90	T19-C	1979-80	4.9L	4x2, 4 Spd, NP435 Trans, Slip On Yoke, 31 Spline Main Shaft, Use 50WT Fluid	NP435-C
1983-87	6.9L	4x4, 4 Spd, T19 Trans, Cast # 13-09 On Case, Use 80W90	T19-D	1979-80	4.9L	4x4, 4 Spd, NP435 Trans, Married Trans, Use 50WT Fluid	NP435-E
1983-87	6.9L	4x4, 4 Spd, T19 Trans, Speedo- Yellow 7T, Cast# 1309 On Case, Use 80W90	T19-B	1979-80	4.9L	4x4, 4 Spd, T18 Trans, Used With Married Transfer Case, Use 80W90	T18-C
1980-86	5.0L, 5.8L, 6.6L, 6.9L, 7.5L	4x2, 4 Spd, T18 Trans, Slip Yolk Style, Cast# 13-01 On Case, Use 80W90	T18-B	1979	4.9L	4x2, 4 Spd, T18 Trans, Bolt On Yolk, Cast# 13-01 On Case, Use 80W90	T18-A
1977-88	5.0L, 5.8L, 6.6L, 6.9L, 7.3L, 7.5L	4x4, 4 Spd, T18 Trans, Used With Married Transfer Case, Use 80W90	T18-C	1979	4.9L	4x2, 4 Spd, T19 Trans, Speedo- Yellow 7T, Cast# 1309 On Case, Use 80W90	T19-A
1977-87	5.0L, 5.8L, 6.6L, 6.9L, 7.5L	4x4, 4 Spd, NP435 Trans, Married Trans, Use 50WT Fluid	NP435-E	1979	4.9L	4x4, 4 Spd, T19 Trans, Cast # 13-09 On Case, Use 80W90	T19-C
1975-87	5.0L, 5.8L, 5.9L, 6.4L, 6.6L, 6.9L, 7.5L	4x2, 4 Spd, NP435 Trans, Bolt On Yoke, 28 Spline Main Shaft, Use 50WT Fluid	NP435-A	8 CYL			
1975-87	5.0L, 5.8L, 5.9L, 6.4L, 6.6L, 6.9L, 7.5L	4x2, 4 Spd, NP435 Trans, Slip On Yoke, 31 Spline Main Shaft, Use 50WT Fluid	NP435-C	1996-97	5.8L	4x2, 5 Spd, S5-47, Covers ZF Tag Number 1317-050-001, Use SYNTHETIC ATF	ZF-001
1975-79	5.0L, 5.8L, 5.9L, 6.4L, 6.6L, 7.5L	4x2, 4 Spd, T18 Trans, Bolt On Yolk, Cast# 13-01 On Case, Use 80W90	T18-A	1996-97	5.8L	4x4, 5 Spd, S5-47, Covers ZF Tag Number 1317-050-002, Use SYNTHETIC ATF	ZF-002
1975-79	5.0L, 5.8L, 5.9L, 6.4L, 6.6L, 7.5L	4x2, 4 Spd, T19 Trans, Speedo- Yellow 7T, Cast# 1309 On Case, Use 80W90	T19-A	1996-97	7.3L	4x2, 5 Spd, S5-47, Covers ZF Tag Number 1317-050-003, Use SYNTHETIC ATF	ZF-003
1975-79	5.0L, 5.8L, 5.9L, 6.4L, 6.6L, 7.5L	4x4, 4 Spd, T19 Trans, Cast # 13-09 On Case, Use 80W90	T19-C	1996-97	7.3L	4x4, 5 Spd, S5-47 Trans, Covers Tag Numbers 1317-050-004 And -012, Use SYNTHETIC ATF	ZF-012
1975-77	5.0L, 5.8L, 5.9L, 6.4L, 6.6L, 7.5L	4x4, 4 Spd, NP435 Trans, Divorced Trans, Use 50WT Fluid	NP435-D	1996-97	7.5L	4x2, 5 Spd, S5-47, Covers ZF Tag Number 1317-050-006, Use SYNTHETIC ATF	ZF-006
				1996-97	7.5L	4x4, 5 Spd, S5-47 Trans, Covers Tag Numbers 1317-050-007 And -013 , Use SYNTHETIC ATF	ZF-013
				1995-96	5.8L	4x2, 5 Spd, S5-42 Trans, Covers ZF Tag Numbers 1307-050-034, -041 And -064, Use SYNTHETIC ATF	ZF-064
				1995-96	5.8L	4x2, 5 Spd, S5-42, Covers ZF Tag Numbers 1307-050-012, -050, -068, -095 And -117, Use SYNTHETIC ATF	ZF-050

Pro King Manual Transmissions

YEAR	ENGINE	APPLICATION	PART NO.	YEAR	ENGINE	APPLICATION	PART NO.
FORD (cont.)				FORD (cont.)			
F-350 SUPER CAB (cont.)				F-350 SUPER CAB (cont.)			
8 CYL (cont.)				8 CYL (cont.)			
1995-96	5.8L	4x2, 5 Spd, ZF S5-42, Covers ZF Tag Numbers 1307-050-039 And -051, Use SYNTHETIC ATF	ZF-051	1980	5.0L, 5.8L, 6.6L	4x2, 4 Spd, T18 Trans, Slip Yolk Style, Cast# 13-01 On Case, Use 80W90	T18-B
1995-96	5.8L	4x4, 5 Spd, S5-42, Covers ZF Tag Numbers 1307-050-011, -052, -079, -096 And -118, Use SYNTHETIC ATF	ZF-118	1977-80	5.0L, 5.8L, 6.6L, 7.5L	4x2, 4 Spd, NP435 Trans, Bolt On Yoke, 28 Spline Main Shaft, Use 50WT Fluid	NP435-A
1994-95	7.3L	4x2, 5 Spd, S5-42, Covers ZF Tag Number 1307-050-108ZW, Use SYNTHETIC ATF	ZF-108	1977-80	5.0L, 5.8L, 6.6L, 7.5L	4x2, 4 Spd, NP435 Trans, Slip On Yoke, 31 Spline Main Shaft, Use 50WT Fluid	NP435-C
1990-92	7.3L, 7.5L	4x4, 4 Spd, T18 Trans, Used With Married Transfer Case, Use 80W90	T18-C	1977-80	5.0L, 5.8L, 6.6L, 7.5L	4x4, 4 Spd, NP435 Trans, Married Trans, Use 50WT Fluid	NP435-E
1990-92	7.5L	4x2, 5 Spd, M5R2 Trans, No Speedo, ATF Used	M5R2-C	1977-80	5.0L, 5.8L, 6.6L, 7.5L	4x4, 4 Spd, T18 Trans, Used With Married Transfer Case, Use 80W90	T18-C
1990-92	7.5L	4x2, 5 Spd, M5R2 Trans, Speedo- Green 8 Teeth, ATF Used	M5R2-B	1977-79	5.0L, 5.8L, 6.6L, 7.5L	4x2, 4 Spd, T18 Trans, Bolt On Yolk, Cast# 13-01 On Case, Use 80W90	T18-A
1990-92	7.5L	4x2, 5 Spd, M5R2 Trans, Speedo- White 8 Teeth, ATF Used	M5R2-D	1977-79	5.0L, 5.8L, 6.6L, 7.5L	4x2, 4 Spd, T19 Trans, Cast# 1309 On Case, Use 80W90	T19-A
1990-92	7.5L	4x4, 5 Spd, M5R2 Trans, No Speedo, ATF Used	M5R2-A	1977-79	5.0L, 5.8L, 6.6L, 7.5L	4x4, 4 Spd, T19 Trans, Cast # 13-09 On Case, Use 80W90	T19-C
1988-95	7.3L	4x2, 5 Spd, S5-42 Trans, Covers ZF Tag Numbers 1307-050-071, -101 And 110ZW, Use SYNTHETIC ATF	ZF-110	1977	5.8L, 6.6L, 7.5L	4x4, 4 Spd, NP435 Trans, Divorced Trans, Use 50WT Fluid	NP435-D
1988-95	7.3L	4x2, 5 Spd, S5-42, Covers ZF Tag Numbers 1307-050-004, -056, -070 And -099, Use SYNTHETIC ATF	ZF-056	F-350 SUPER DUTY			
1988-95	7.3L	4x2, 5 Spd, S5-42, Covers ZF Tag Numbers 1307-050-022 And -059, Use SYNTHETIC ATF	ZF-059	8 CYL			
1988-95	7.3L	4x2, 5 Spd, S5-42, Covers ZF Tag Numbers 1307-050-035, -038 And -057, Use SYNTHETIC ATF	ZF-057	2003-05	6.0L	4x2, 6 Spd, 6S-750 Trans, Use SYNTHETIC ATF	ZF-704
1988-95	7.3L	4x4, 5 Spd, S5-42 Trans, Covers ZF Tag Numbers 1307-050-021, -032, -060, -082, -102 And 111ZW, Use SYNTHETIC ATF	ZF-111	2003-05	6.0L	4x4, 6 Spd, 6S-750 Trans, Use SYNTHETIC ATF	ZF-705
1988-95	7.3L	4x4, 5 Spd, S5-42, Covers ZF Tag Number 1307-050-058, No Speedo, 4.10 Axle 4.14-0.77 Ratio, Use SYNTHETIC ATF	ZF-109	2001-03	7.3L	4x2, 6 Spd, S6-650 Trans, Use SYNTHETIC ATF	ZF-624
1988-95	7.5L	4x2, 5 Spd, S5-42, Covers ZF Tag Numbers 1307-050-014, -053, -069, -097 And -119, Use SYNTHETIC ATF	ZF-053	2001-02	7.3L	4x4, 6 Spd, S6-650 Trans, Use SYNTHETIC ATF	ZF-625
1988-95	7.5L	4x2, 5 Spd, S5-42, Covers ZF Tag Numbers 1307-050-040 And -054, Use SYNTHETIC ATF	ZF-054	1999-02	5.4L	4x2, 5 Spd, S5-47, Covers ZF Tag Number 1317-050-001, Use SYNTHETIC ATF	ZF-001
1988-95	7.5L	4x4, 5 Spd, S5-42, Covers ZF Tag Numbers 1307-050-003, -030, -042, -055, -080, -098 And -120, Use SYNTHETIC ATF	ZF-120	1999-02	5.4L	4x4, 5 Spd, S5-47, Covers ZF Tag Number 1317-050-002, Use SYNTHETIC ATF	ZF-002
1988	7.3L, 7.5L	4x4, 4 Spd, T18 Trans, Used With Married Transfer Case, Use 80W90	T18-C	1999-02	7.3L	4x2, 5 Spd, S5-47, Covers ZF Tag Number 1317-050-003, Use SYNTHETIC ATF	ZF-003
				10 CYL			
				2002-05	6.8L	4x4, 6 Spd, S6-650 Trans, Covers ZF Tag Number 1319-050-044, Use SYNTHETIC ATF	ZF-644

Pro King Manual Transmissions

YEAR	ENGINE	APPLICATION	PART NO.	YEAR	ENGINE	APPLICATION	PART NO.
FORD (cont.)				FORD (cont.)			
F-450 PICKUP				F53			
8 CYL				8 CYL			
2005-06	6.0L	4x2, 6 Spd, 6S-750 Trans, Use SYNTHETIC ATF	ZF-704	1996-97	7.5L	4x2, 5 Spd, S5-47, Covers ZF Tag Number 1317-050-006, Use SYNTHETIC ATF	ZF-006
2005-06	6.0L	4x4, 6 Spd, 6S-750 Trans, Use SYNTHETIC ATF	ZF-705	1996-97	7.5L	4x4, 5 Spd, S5-47 Trans, Covers Tag Numbers 1317-050-007 And -013 , Use SYNTHETIC ATF	ZF-013
10 CYL				8 CYL			
2005-06	6.8L	4x4, 6 Spd, S6-650 Trans, Covers ZF Tag Number 1319-050-044, Use SYNTHETIC ATF	ZF-644	1988-95	7.5L	4x2, 5 Spd, S5-42, Covers ZF Tag Numbers 1307-050-014, -053, -069, -097 And -119, Use SYNTHETIC ATF	ZF-053
F-450 SUPER DUTY				F-550 PICKUP			
8 CYL				8 CYL			
2003-04	6.0L	4x2, 6 Spd, 6S-750 Trans, Use SYNTHETIC ATF	ZF-704	2005-06	6.0L	4x2, 6 Spd, 6S-750 Trans, Use SYNTHETIC ATF	ZF-704
2003-04	6.0L	4x4, 6 Spd, 6S-750 Trans, Use SYNTHETIC ATF	ZF-705	2005-06	6.0L	4x4, 6 Spd, 6S-750 Trans, Use SYNTHETIC ATF	ZF-705
2001-03	7.3L	4x2, 6 Spd, S6-650 Trans, Use SYNTHETIC ATF	ZF-624	10 CYL			
2001-02	7.3L	4x4, 6 Spd, S6-650 Trans, Use SYNTHETIC ATF	ZF-625	2005-06	6.8L	4x4, 6 Spd, S6-650 Trans, Covers ZF Tag Number 1319-050-044, Use SYNTHETIC ATF	ZF-644
1999-02	7.3L	4x2, 5 Spd, S5-47, Covers ZF Tag Number 1317-050-003, Use SYNTHETIC ATF	ZF-003	F-550 SUPER DUTY			
1999-02	7.3L	4x4, 5 Spd, S5-47 Trans, Covers Tag Numbers 1317-050-004 And -012, Use SYNTHETIC ATF	ZF-012	8 CYL			
1999-00	7.3L	4x2, 6 Spd, S6-650, Covers ZF Tag Numbers 1319-050-004 And -005, Use SYNTHETIC ATF	ZF-605	2003-04	6.0L	4x2, 6 Spd, 6S-750 Trans, Use SYNTHETIC ATF	ZF-704
1999-00	7.3L	4x4, 6 Spd, S6-650, Covers ZF Tag Numbers 1319-050-002 And -006, Use SYNTHETIC ATF	ZF-606	2003-04	6.0L	4x4, 6 Spd, 6S-750 Trans, Use SYNTHETIC ATF	ZF-705
10 CYL				2002	7.3L	4x2, 5 Spd, S5-47, Covers ZF Tag Number 1317-050-003, Use SYNTHETIC ATF	ZF-003
2002-04	6.8L	4x4, 6 Spd, S6-650 Trans, Covers ZF Tag Number 1319-050-044, Use SYNTHETIC ATF	ZF-644	2002	7.3L	4x4, 5 Spd, S5-47 Trans, Covers Tag Numbers 1317-050-004 And -012, Use SYNTHETIC ATF	ZF-012
F-500				10 CYL			
8 CYL				2002-04	6.8L	4x4, 6 Spd, S6-650 Trans, Covers ZF Tag Number 1319-050-044, Use SYNTHETIC ATF	ZF-644
1977	5.4L, 5.9L, 6.4L	4x4, 4 Spd, NP435 Trans, Married Trans, Use 50WT Fluid	NP435-E	8 CYL			
1977	5.4L, 5.9L, 6.4L	4x4, 4 Spd, T18 Trans, Used With Married Transfer Case, Use 80W90	T18-C	2003-04	6.0L	4x2, 6 Spd, 6S-750 Trans, Use SYNTHETIC ATF	ZF-704
1975-77	5.4L, 5.9L, 6.4L	4x2, 4 Spd, NP435 Trans, Bolt On Yoke, 28 Spline Main Shaft, Use 50WT Fluid	NP435-A	2003-04	6.0L	4x4, 6 Spd, 6S-750 Trans, Use SYNTHETIC ATF	ZF-705
1975-77	5.4L, 5.9L, 6.4L	4x2, 4 Spd, NP435 Trans, Slip On Yoke, 31 Spline Main Shaft, Use 50WT Fluid	NP435-C	2001-03	7.3L	4x2, 6 Spd, S6-650 Trans, Use SYNTHETIC ATF	ZF-624
1975-77	5.4L, 5.9L, 6.4L	4x2, 4 Spd, T18 Trans, Bolt On Yolk, Cast# 13-01 On Case, Use 80W90	T18-A	2001-02	7.3L	4x4, 6 Spd, S6-650 Trans, Use SYNTHETIC ATF	ZF-625
1975-77	5.4L, 5.9L, 6.4L	4x2, 4 Spd, T19 Trans, Speedo- Yellow 7T, Cast# 1309 On Case, Use 80W90	T19-A	1999-00	7.3L	4x2, 6 Spd, S6-650, Covers ZF Tag Numbers 1319-050-004 And -005, Use SYNTHETIC ATF	ZF-605
1975-77	5.4L, 5.9L, 6.4L	4x4, 4 Spd, NP435 Trans, Divorced Trans, Use 50WT Fluid	NP435-D	1999-00	7.3L	4x4, 6 Spd, S6-650, Covers ZF Tag Numbers 1319-050-002 And -006, Use SYNTHETIC ATF	ZF-606
1975-77	5.4L, 5.9L, 6.4L	4x4, 4 Spd, T19 Trans, Cast # 13-09 On Case, Use 80W90	T19-C	10 CYL			

Pro King Manual Transmissions

YEAR	ENGINE	APPLICATION	PART NO.	YEAR	ENGINE	APPLICATION	PART NO.
FORD (cont.)				FORD (cont.)			
F59				MUSTANG (cont.)			
8 CYL				8 CYL (cont.)			
1994	7.3L	4x2, 5 Spd, S5-42, Covers ZF Tag Number 1307-050-108ZW, Use SYNTHETIC ATF	ZF-108	1993	5.0L	5 Spd, Borg Warner T5 WC, CORE REQUIRED, REBUILD AND RETURN ONLY, Speedo- Aqua, ATF Used	T5-FE
1988-94	7.3L	4x2, 5 Spd, S5-42 Trans, Covers ZF Tag Numbers 1307-050-071, -101 And 110ZW, Use SYNTHETIC ATF	ZF-110	1985-93	5.0L	5 Spd, Borg Warner T5 WC, Speedo- Yellow, ATF Used	T5-FD
1988-94	7.3L	4x2, 5 Spd, S5-42, Covers ZF Tag Numbers 1307-050-004, -056, -070 And -099, Use SYNTHETIC ATF	ZF-056	P-350			
1988-94	7.3L	4x2, 5 Spd, S5-42, Covers ZF Tag Numbers 1307-050-022 And -059, Use SYNTHETIC ATF	ZF-059	6 CYL			
1988-94	7.3L	4x2, 5 Spd, S5-42, Covers ZF Tag Numbers 1307-050-035, -038 And -057, Use SYNTHETIC ATF	ZF-057	1975-76	4.9L	4x2, 4 Spd, NP435 Trans, Bolt On Yoke, 28 Spline Main Shaft, Use 50WT Fluid	NP435-A
1988-94	7.3L	4x4, 5 Spd, S5-42 Trans, Covers ZF Tag Numbers 1307-050-021, -032, -060, -082, -102 And 111ZW, Use SYNTHETIC ATF	ZF-111	1975-76	4.9L	4x2, 4 Spd, NP435 Trans, Slip On Yoke, 31 Spline Main Shaft, Use 50WT Fluid	NP435-C
1988-94	7.3L	4x4, 5 Spd, S5-42, Covers ZF Tag Number 1307-050-058, No Speedo, 4.10 Axle 4.14-0.77 Ratio, Use SYNTHETIC ATF	ZF-109	1975-76	4.9L	4x4, 4 Spd, NP435 Trans, Divorced Trans, Use 50WT Fluid	NP435-D
MUSTANG				8 CYL			
4 CYL				1976	5.0L, 6.6L	4x2, 4 Spd, NP435 Trans, Bolt On Yoke, 28 Spline Main Shaft, Use 50WT Fluid	NP435-A
1985-93	2.3L	5 Spd, Borg Warner T5 WC, Speedo- Yellow, ATF Used	T5-FC	1976	5.0L, 6.6L	4x2, 4 Spd, NP435 Trans, Slip On Yoke, 31 Spline Main Shaft, Use 50WT Fluid	NP435-C
6 CYL				1976	5.0L, 6.6L	4x4, 4 Spd, NP435 Trans, Divorced Trans, Use 50WT Fluid	NP435-D
1999-06	3.8L, 3.9L, 4.0L	5 Spd, Borg Warner T5 WC, CORE REQUIRED, REBUILD AND RETURN ONLY, Electric Speedo, ATF Used	T5-FI	P-400			
1994-98	3.8L	5 Spd, Borg Warner T5 WC, Speedo- Aqua, ATF Used	T5-FG	6 CYL			
1984-86	3.8L	5 Spd, Borg Warner T5 WC, Speedo- Yellow, ATF Used	T5-FC	1975-76	4.9L	4x2, 4 Spd, NP435 Trans, Bolt On Yoke, 28 Spline Main Shaft, Use 50WT Fluid	NP435-A
8 CYL				1975-76	4.9L	4x2, 4 Spd, NP435 Trans, Slip On Yoke, 31 Spline Main Shaft, Use 50WT Fluid	NP435-C
2005-08	4.6L	5 Spd, TR3650 Trans, Cast "CCCA1271AG", Bolt-On Yoke, Use Mercon ATF	TR3650-B	1975-76	4.9L	4x4, 4 Spd, NP435 Trans, Divorced Trans, Use 50WT Fluid	NP435-D
2001-04	4.6L	5 Spd, TR3650 Trans, Cast "CCCA1271AG", Slip-On Yoke, Use Mercon ATF	TR3650-A	P-500			
1999-00	4.6L	5 Spd, T45 Trans, With Electric Speedo, Use ATF	T45-C	6 CYL			
1996-98	4.6L	5 Spd, T45 Trans, Aluminum Case With Cast #13-81, Use ATF	T45-A	1977	4.9L	4x4, 4 Spd, NP435 Trans, Married Trans, Use 50WT Fluid	NP435-E
1996-98	4.6L	5 Spd, T45 Trans, Aluminum Case With Cast #13-81, Use ATF	T45-B	1975-77	4.9L	4x2, 4 Spd, NP435 Trans, Bolt On Yoke, 28 Spline Main Shaft, Use 50WT Fluid	NP435-A
1994-95	5.0L	5 Spd, Borg Warner T5 WC, CORE REQUIRED, REBUILD AND RETURN ONLY, Speedo- Aqua, ATF Used	T5-FF	1975-77	4.9L	4x2, 4 Spd, NP435 Trans, Slip On Yoke, 31 Spline Main Shaft, Use 50WT Fluid	NP435-C
1994-95	5.0L	5 Spd, Borg Warner T5 WC, Speedo- Aqua, ATF Used	T5-FG	1975-77	4.9L	4x4, 4 Spd, NP435 Trans, Divorced Trans, Use 50WT Fluid	NP435-D
MUSTANG				PROBE			
4 CYL				4 CYL			
6 CYL				1989-97	2.0L, 2.2L	5 Spd, PR5 Trans, Black Metal Cover, CORE REQUIRED, REBUILD AND RETURN ONLY	PR5
8 CYL				6 CYL			
4 CYL				1993-97	2.5L	5 Spd, PR5 Trans, Aluminum Case, CORE REQUIRED, REBUILD AND RETURN ONLY	PR5-A

Pro King Manual Transmissions

YEAR	ENGINE	APPLICATION	PART NO.	YEAR	ENGINE	APPLICATION	PART NO.
FORD (cont.)				FORD (cont.)			
RANCHERO				RANGER (cont.)			
8 CYL				6 CYL (cont.)			
1975-77	5.0L, 5.8L, 6.6L, 7.5L	4x2, 4 Spd, T19 Trans, Speedo- Yellow 7T, Cast# 1309 On Case, Use 80W90	T19-A	1995-00	3.0L	4x2, 5 Spd, M5R1 Trans, No Speedo, Use ATF	M5R1-JA
1975-77	5.0L, 5.8L, 6.6L, 7.5L	4x4, 4 Spd, T19 Trans, Cast # 13-09 On Case, Use 80W90	T19-C	1995-00	4.0L	4x2, 5 Spd, M5R1 Trans, No Speedo, Use ATF	M5R1-DA
1975-76	5.8L, 6.6L, 7.5L	4x2, 4 Spd, NP435 Trans, Bolt On Yoke, 28 Spline Main Shaft, Use 50WT Fluid	NP435-A	1995-00	4.0L	4x2, 5 Spd, M5R1 Trans, With 6 Tooth Purple Speedo Gear, Use ATF	M5R1-CA
1975-76	5.8L, 6.6L, 7.5L	4x2, 4 Spd, NP435 Trans, Slip On Yoke, 31 Spline Main Shaft, Use 50WT Fluid	NP435-C	1995-00	4.0L	4x2, 5 Spd, M5R1, Speedo- White 7 teeth, ATF Used, One Switch on Top Cover	M5R1-EA
1975-76	5.8L, 6.6L, 7.5L	4x4, 4 Spd, NP435 Trans, Divorced Trans, Use 50WT Fluid	NP435-D	1995-00	4.0L	4x4, 5 Spd, M5R1 Trans, Use ATF	M5R1-BA
RANGER				6 CYL (cont.)			
4 CYL				6 CYL (cont.)			
2000-05	2.3L, 2.5L	4x2, 5 Spd, M5R1 Trans, CORE REQUIRED, REBUILD AND RETURN ONLY, Use ATF	M5R1-T	1991-94	3.0L	4x2, 5 Spd, M5R1 Trans, Speedo- Purple 6 teeth, ATF Used, 3 Hole Starter Left Side	M5R1-I
1998-00	2.5L	4x2, 5 Spd, M5R1 Trans, 1 Switch In top Cover, No Speedo, Use ATF	M5R1-PA	1991-94	3.0L	4x2, 5 Spd, M5R1 Trans, Speedo- White 7 teeth, ATF Used, 3 Hole Starter Left Side	M5R1-K
1995-96	2.3L	4x2, 5 Spd, M5R1 Trans, 1 Switch In top Cover, No Speedo, Use ATF	M5R1-PA	1991-94	3.0L	4x4, 5 Spd, M5R1 Trans, No Speedo, ATF Used, 3 Hole Starter Left Side	M5R1-H
1995-96	2.3L	4x4, 5 Spd, M5R1 Trans, 1 Switch In top Cover, Use ATF	M5R1-LA	1990-94	2.9L, 4.0L	4x2, 5 Spd, M5R1 Trans, No Speedo, ATF Used, 2 Hole Starter Left Side	M5R1-D
1993-94	2.3L	4x2, 5 Spd, M5R1 Trans, No Speedo, ATF Used, 3 Hole Starter Right Side, 1 Switch In Top Cover	M5R1-P	1988-94	2.9L, 4.0L	4x2, 5 Spd, M5R1 Trans, Speedo- Purple 6 teeth, ATF Used, 2 Hole Starter Left Side	M5R1-C
1988-94	2.0L, 2.3L	4x2, 5 Spd, M5R1 Trans, Speedo- White 7 teeth, ATF Used, 3 Hole Starter Right Side, 1 Switch In Top Cover	M5R1-Q	1988-94	2.9L, 4.0L	4x2, 5 Spd, M5R1 Trans, Speedo- White 7 teeth, ATF Used, 2 Hole Starter Left Side	M5R1-E
1988-94	2.0L, 2.3L	4x2, 5 Spd, M5R1 Trans, Speedo- White 7 teeth, ATF Used, 3 Hole Starter Right Side, 2 Switches In Top Cover	M5R1-R	1988-94	2.9L, 4.0L	4x4, 5 Spd, M5R1 Trans, No Speedo, ATF Used, 2 Hole Starter Left Side, Use ATF	M5R1-B
1988-94	2.0L, 2.3L	4x4, 5 Spd, M5R1 Trans, No Speedo, ATF Used, 1 Switch Top Cover	M5R1-L	1988-92	2.9L	4x4, 5 Spd, FM146, No Speedo, 75w90 Used, Shifter Towards Front, Steel Bottom Pan, 13" Extension Housing	FM-146
1988-94	2.0L, 2.3L	4x4, 5 Spd, M5R1 Trans, No Speedo, ATF Used, 2 Switches Top Cover	M5R1-M	1985-87	2.8L, 2.9L	4x2, 5 Spd, TK5 Trans, Beige Speedo Gear, Internal Slave Cylinder, Use SYNTHETIC 75W90	TK5-H
1985-87	2.0L, 2.3L	4x2, 5 Spd, TK5 Trans, Beige Speedo Gear, Internal Slave Cylinder, Use SYNTHETIC 75W90	TK5-H	1985-87	2.8L, 2.9L	4x2, 5 Spd, TK5 Trans, Black Speedo Gear, Internal Slave Cylinder, Use SYNTHETIC 75W90	TK5-G
1985-87	2.0L, 2.3L	4x2, 5 Spd, TK5 Trans, Black Speedo Gear, Internal Slave Cylinder, Use SYNTHETIC 75W90	TK5-G	1985-87	2.8L, 2.9L	4x4, 5 Spd, FM145, No Speedo, 75w90 Used, Shifter Towards Front, Steel Bottom Pan, 10.5" Extension Housing	FM-145
1985-87	2.0L, 2.3L	4x4, 5 Spd, TK5 Trans, Use Synthetic 75W90	TK5-I	1985-87	2.8L, 2.9L	4x4, 5 Spd, TK5 Trans, Use Synthetic 75W90	TK5-I
6 CYL				THUNDERBIRD			
2001-06	4.0L	4x4, 5 Spd, M5R1 Trans, With Speedo Sensor In Tail Housing, Use ATF	M5R1-BB	4 CYL			
2000-06	3.0L	4x2, 5 Spd, M5R1 Trans, CORE REQUIRED, REBUILD AND RETURN ONLY, 1 Switch in top Cover, Trigger Wheel Speedo, Use ATF	M5R1-S	1985-88	2.3L	5 Spd, Borg Warner T5 WC, Speedo- Yellow, ATF Used	T5-FC
1995-05	3.0L	4x4, 5 Spd, M5R1 Trans, Use ATF	M5R1-HA	6 CYL			
				1997	3.8L	4x2, 5 Spd, M5R2 Trans, Speedo- Green 8 teeth, ATF Used, CORE REQUIRED, REBUILD AND RETURN ONLY	M5R2-G

Pro King Manual Transmissions

YEAR	ENGINE	APPLICATION	PART NO.	YEAR	ENGINE	APPLICATION	PART NO.
FORD (cont.)				GMC			
THUNDERBIRD (cont.)				"S15 JIMMY, PICKUP"			
6 CYL (cont.)				4 CYL			
1990-96	3.8L	4x2, 5 Spd, M5R2 Trans, No Speedo, ATF Used	M5R2-C	1986-88	2.5L	4x2, 5 Spd, Borg Warner T5, T5-CG Speedo- Red, ATF Used	
1990-96	3.8L	4x2, 5 Spd, M5R2 Trans, Speedo- Green 8 Teeth, ATF Used	M5R2-B	1986-88	2.5L	4x4, 5 Spd, Borg Warner T5 Non WC, No Speedo, ATF Used	T5-CF
1990-96	3.8L	4x2, 5 Spd, M5R2 Trans, Speedo- White 8 Teeth, ATF Used	M5R2-D	1983-84	1.9L, 2.0L	4x2, 5 Spd, Borg Warner T5, T5-CG Speedo- Red, ATF Used	
8 CYL				1983-84	1.9L, 2.0L	4x4, 5 Spd, Borg Warner T5 Non WC, No Speedo, ATF Used	T5-CF
2002-03	3.9L	4x2, 5 Spd, M5R2 Trans, CORE REQUIRED, REBUILD AND RETURN ONLY, Use ATF	M5R2-L	6 CYL			
1997	4.6L	4x2, 5 Spd, M5R2 Trans, Speedo- Green 8 Teeth, ATF Used, CORE REQUIRED, REBUILD AND RETURN ONLY	M5R2-H	2001	4.3L	4x2, 5 Spd, Getrag NV3500 Trans, Electric Speedo Screw in, GM# 1234539 Fluid Used, 18.5" Tail Housing, Alum. Case, Code GBDX	290-J
1991-96	4.6L, 5.0L	4x2, 5 Spd, M5R2 Trans, No Speedo, ATF Used	M5R2-C	1998-00	4.3L	4x2, 5 Spd, Getrag NV3500 Trans, Press in Speedo, GM# 1234539 Fluid Used, 15" Tail Housing, Alum. Case, Code GADT	290-E
1991-96	4.6L, 5.0L	4x2, 5 Spd, M5R2 Trans, Speedo- Green 8 Teeth, ATF Used	M5R2-B	1998-00	4.3L	4x4, 5 Spd, Getrag NV3500 Trans, CORE REQUIRED, REBUILD AND RETURN ONLY, No Speedo, GM# 1234539 Fluid Used, 14" Tail Housing, Code GADU	290-D
1991-96	4.6L, 5.0L	4x2, 5 Spd, M5R2 Trans, Speedo- White 8 Teeth, ATF Used	M5R2-D	1990-94	4.3L	4x2, 5 Spd, Getrag NV3500 Trans, Press in Electric Speedo, GM# 1234539 Fluid Used, 18.5" Tail Housing, Code GWF	290-G
GEO				1990-94	4.3L	4x4, 5 Spd, Getrag NV3500 Trans, No Speedo, GM# 1234539 Fluid Used, 13" Tail Housing, Code GWH	290-F
PRIZM				1989	2.8L	4x2, 5 Spd, T5 Trans, Electric Speedo, ATF Used	T5-CH
4 CYL				1986-89	2.8L	4x4, 5 Spd, Borg Warner T5 Non WC, No Speedo, ATF Used	T5-CF
1993-97	1.6L, 1.8L	5 Spd, C51 Trans, CORE REQUIRED, REBUILD AND RETURN ONLY, Use SYNTHETIC 75W90	C51	1986-88	2.8L	4x2, 5 Spd, Borg Warner T5, T5-CG Speedo- Red, ATF Used	
1989	1.6L	5 Spd, C51 Trans, CORE REQUIRED, REBUILD AND RETURN ONLY, Use SYNTHETIC 75W90	C51	1983-84	2.8L	4x2, 5 Spd, Borg Warner T5, T5-CG Speedo- Red, ATF Used	
SPECTRUM				1983-84	2.8L	4x4, 5 Spd, Borg Warner T5 Non WC, No Speedo, ATF Used	T5-CF
4 CYL				"SIERRA 1500, DENALI"			
1989	1.5L	5 Spd, MR8 Isuzu Style Trans, Aluminum Rear Cover Over 5th Gears, CORE REQUIRED, REBUILD AND RETURN ONLY, Use GM# 12345349 Fluid	MR8	6 CYL			
STORM				1999-00	4.3L	4x2, 5 Spd, Getrag NV3500 Trans, Press in Speedo, GM# 1234539 Fluid Used, 15" Tail Housing, Alum. Case, Code GADT	290-E
4 CYL				1999-00	4.3L	4x4, 5 Spd, Getrag NV3500 Trans, CORE REQUIRED, REBUILD AND RETURN ONLY, No Speedo, GM# 1234539 Fluid Used, 14" Tail Housing, Code GADU	290-D
1990-93	1.6L, 1.8L	5 Spd, STORM Trans, Aluminum Back Cover Over 5th Gear, Isuzu Style Trans, CORE REQUIRED, REBUILD AND RETURN ONLY	MV4	8 CYL			
TRACKER				1999-05	4.8L	4x4, 5 Spd, Getrag NV3500 Trans, No Speedo, GM# 1234539 Fluid Used, 14" Tail Housing, Code GBKT	290-M
4 CYL							
1989-97	1.6L	4x2, 5 Spd, TRACKER Trans, Use 75W90	SIDE-A				
1989-97	1.6L	4x4, 5 Spd, TRACKER Trans, Use 75W90	SIDE-B				

Pro King Manual Transmissions

YEAR	ENGINE	APPLICATION	PART NO.	YEAR	ENGINE	APPLICATION	PART NO.
GMC (cont.)				GMC (cont.)			
"SIERRA 1500, DENALI" (cont.)				C1500 (cont.)			
8 CYL (cont.)				6 CYL (cont.)			
1999-05	5.3L	4x2, 5 Spd, Getrag NV3500 Trans, Electric Speedo Screw in, GM# 1234539 Fluid Used, 18.5" Tail Housing, Alum. Case, Code GBDX	290-J	1998	4.3L	4x2, 5 Spd, NV4500 Trans, W/Speedo, Cast Iron Case, Flat Aluminum Front Retainer, 6" Tail Housing, Code GBBN, Use GM# 12346190 Fluid	NV4500-J
C15				1988	4.3L	4 Spd, NP833 Trans (3 Spd w/OD), Iron Case Or Aluminum Case, 10 Bolt Side Cover, CORE REQUIRED, REBUILD AND RETURN ONLY, Use ATF	NP833O/D
6 CYL				1988	4.3L	4x2, 4 Spd, SM465 Trans, Aluminum Top Cover With Electric Speedo, Use GM# 12345577 Fluid	SM465-H
1975-78	4.1L, 4.8L	4x2, 4 Spd, SM465 Trans, With Tail Housing Mount, Use 80W90	SM465-B	1988	4.3L	4x2, 4 Spd, SM465 Trans, Aluminum Top Cover With Mechanical Speedo, Use GM# 12345577 Fluid	SM465-G
8 CYL				1988	4.3L	4x2, 5 Spd, Getrag NV3500 Trans, GM# 1234539 Fluid Used	290-B
1975-78	5.0L, 5.7L, 6.6L, 7.4L	4x2, 4 Spd, SM465 Trans, With Tail Housing Mount, Use 80W90	SM465-B	1986	4.3L	4 Spd, NP833 Trans (3 Spd w/OD), Iron Case Or Aluminum Case, 10 Bolt Side Cover, CORE REQUIRED, REBUILD AND RETURN ONLY, Use ATF	NP833O/D
C15 BIG TEN				1981-84	4.1L	4 Spd, NP833 Trans (3 Spd w/OD), Iron Case Or Aluminum Case, 10 Bolt Side Cover, CORE REQUIRED, REBUILD AND RETURN ONLY, Use ATF	NP833O/D
6 CYL				1979-86	4.1L, 4.3L, 4.8L	4x2, 4 Spd, SM465 Trans, With Tail Housing Mount, Use 80W90	SM465-B
1977-78	4.1L, 4.8L	4x2, 4 Spd, SM465 Trans, With Tail Housing Mount, Use 80W90	SM465-B	8 CYL			
8 CYL				1998	5.0L, 5.7L	4x2, 5 Spd, NV4500 Trans, W/Speedo, Cast Iron Case, 6" Tail Housing, Flat Aluminum Front Retainer, Code GAMN, Use GM# 12346190 Fluid	NV4500-G
1977-78	5.0L, 5.7L, 7.4L	4x2, 4 Spd, SM465 Trans, With Tail Housing Mount, Use 80W90	SM465-B	1998	5.0L, 5.7L	4x2, 5 Spd, NV4500 Trans, W/Speedo, Cast Iron Case, Flat Aluminum Front Retainer, 6" Tail Housing, Code GBBN, Use GM# 12346190 Fluid	NV4500-J
C15 SUBURBAN				1998	5.7L	4x2, 5 Spd, Getrag NV3500 Trans, Press in Speedo, GM# 1234539 Fluid Used, 15" Tail Housing, Alum. Case, Code GADT	290-E
6 CYL				1988	5.0L, 5.7L, 6.2L	4 Spd, NP833 Trans (3 Spd w/OD), Iron Case Or Aluminum Case, 10 Bolt Side Cover, CORE REQUIRED, REBUILD AND RETURN ONLY, Use ATF	NP833O/D
1975-78	4.1L	4x2, 4 Spd, SM465 Trans, With Tail Housing Mount, Use 80W90	SM465-B	1988	5.0L, 5.7L, 6.2L	4x2, 4 Spd, SM465 Trans, Aluminum Top Cover With Electric Speedo, Use GM# 12345577 Fluid	SM465-H
8 CYL				1988	5.0L, 5.7L, 6.2L	4x2, 4 Spd, SM465 Trans, Aluminum Top Cover With Mechanical Speedo, Use GM# 12345577 Fluid	SM465-G
1975-78	5.0L, 5.7L, 7.4L	4x2, 4 Spd, SM465 Trans, With Tail Housing Mount, Use 80W90	SM465-B	C15/C1500 PICKUP & SUBURBAN			
6 CYL				1979-80	4.1L	4x2, 4 Spd, SM465 Trans, With Tail Housing Mount, Use 80W90	SM465-B
8 CYL				1981-84	5.0L, 5.7L, 6.2L	4 Spd, NP833 Trans (3 Spd w/OD), Iron Case Or Aluminum Case, 10 Bolt Side Cover, CORE REQUIRED, REBUILD AND RETURN ONLY, Use ATF	NP833O/D
1979-84	5.0L, 5.7L, 6.2L, 7.4L	4x2, 4 Spd, SM465 Trans, With Tail Housing Mount, Use 80W90	SM465-B	C1500			
6 CYL				1998	4.3L	4x2, 5 Spd, Getrag NV3500 Trans, Press in Speedo, GM# 1234539 Fluid Used, 15" Tail Housing, Alum. Case, Code GADT	290-E
1979-84	5.0L, 5.7L, 6.2L, 7.4L	4x2, 4 Spd, SM465 Trans, With Tail Housing Mount, Use 80W90	SM465-B	1998	4.3L	4x2, 5 Spd, NV4500 Trans, W/Speedo, Cast Iron Case, 6" Tail Housing, Flat Aluminum Front Retainer, Code GAMN, Use GM# 12346190 Fluid	NV4500-G

Pro King Manual Transmissions

YEAR	ENGINE	APPLICATION	PART NO.	YEAR	ENGINE	APPLICATION	PART NO.
GMC (cont.)				GMC (cont.)			
C1500 (cont.)				C1500 SIERRA (cont.)			
8 CYL (cont.)				6 CYL (cont.)			
1988	5.0L, 5.7L, 6.2L	4x2, 5 Spd, Getrag NV3500 Trans, GM# 1234539 Fluid Used	290-B	1989-91	4.3L	4x2, 4 Spd, SM465 Trans, Aluminum Top Cover With Mechanical Speedo, Use GM# 12345577 Fluid	SM465-G
1986	5.0L, 5.7L, 6.2L	4 Spd, NP833 Trans (3 Spd w/OD), Iron Case Or Aluminum Case, 10 Bolt Side Cover, CORE REQUIRED, REBUILD AND RETURN ONLY, Use ATF	NP833O/D	1989	4.3L	4 Spd, NP833 Trans (3 Spd w/OD), Iron Case Or Aluminum Case, 10 Bolt Side Cover, CORE REQUIRED, REBUILD AND RETURN ONLY, Use ATF	NP833O/D
1981-84	5.0L, 5.7L, 6.2L	4 Spd, NP833 Trans (3 Spd w/OD), Iron Case Or Aluminum Case, 10 Bolt Side Cover, CORE REQUIRED, REBUILD AND RETURN ONLY, Use ATF	NP833O/D	8 CYL			
1979-86	5.0L, 5.7L, 6.2L, 6.6L, 7.4L	4x2, 4 Spd, SM465 Trans, With Tail Housing Mount, Use 80W90	SM465-B	1997	5.0L, 5.7L	4x2, 5 Spd, NV4500 Trans, W/Speedo, Cast Iron Case, 6" Tail Housing, Flat Aluminum Front Retainer, Code GAMN, Use GM# 12346190 Fluid	NV4500-G
C1500 BIG TEN				1997	5.0L, 5.7L, 6.5L	4x2, 5 Spd, NV4500 Trans, W/Speedo, Cast Iron Case, Flat Aluminum Front Retainer, 6" Tail Housing, Code GBBN, Use GM# 12346190 Fluid	NV4500-J
6 CYL				1996-97	5.0L, 5.7L, 6.5L	4x2, 5 Spd, Getrag NV3500 Trans, Press in Speedo, GM# 1234539 Fluid Used, 15" Tail Housing, Alum. Case, Code GADT	290-E
1979-80	4.1L, 4.8L	4x2, 4 Spd, SM465 Trans, With Tail Housing Mount, Use 80W90	SM465-B	1993-95	5.0L, 5.7L	4x2, 5 Spd, NV4500 Trans, W/Speedo, 6" Tail Housing, Cast Iron Case, Cast Iron Front Retainer, Code GAKF, Use GM# 12346190 Fluid	NV4500-C
8 CYL				1993-95	5.0L, 5.7L, 6.2L, 6.5L	4x2, 5 Spd, Getrag NV3500 Trans, GM# 1234539 Fluid Used, REBUILDABLE CORE REQUIRED, REBUILD AND RETURN ONLY, FRONT CASE MUST BE IN GOOD CONDITION	290-C
1979-80	5.0L, 5.7L, 6.6L, 7.4L	4x2, 4 Spd, SM465 Trans, With Tail Housing Mount, Use 80W90	SM465-B	1993-95	5.0L, 5.7L, 6.2L, 6.5L	4x2, 5 Spd, NV4500 Trans, W/Speedo, With Parking Brake, Code GXW, Use GM# 12346190 Fluid	NV4500-I
C1500 SIERRA				1993-95	6.2L, 6.5L	4x2, 5 Spd, NV4500 Trans, W/Speedo, Without Parking Brake, Code GAKH, Use GM# 12346190 Fluid	NV4500-D
6 CYL				1989-92	5.0L, 5.7L, 6.2L	4x2, 5 Spd, Getrag NV3500 Trans, GM# 1234539 Fluid Used	290-B
1997	4.3L	4x2, 5 Spd, NV4500 Trans, W/Speedo, Cast Iron Case, 6" Tail Housing, Flat Aluminum Front Retainer, Code GAMN, Use GM# 12346190 Fluid	NV4500-G	1989-91	5.0L, 5.7L, 6.2L	4x2, 4 Spd, SM465 Trans, Aluminum Top Cover With Electric Speedo, Use GM# 12345577 Fluid	SM465-H
1997	4.3L	4x2, 5 Spd, NV4500 Trans, W/Speedo, Cast Iron Case, Flat Aluminum Front Retainer, 6" Tail Housing, Code GBBN, Use GM# 12346190 Fluid	NV4500-J	1989-91	5.0L, 5.7L, 6.2L	4x2, 4 Spd, SM465 Trans, Aluminum Top Cover With Mechanical Speedo, Use GM# 12345577 Fluid	SM465-G
1996-97	4.3L	4x2, 5 Spd, Getrag NV3500 Trans, Press in Speedo, GM# 1234539 Fluid Used, 15" Tail Housing, Alum. Case, Code GADT	290-E	1989	5.0L, 5.7L, 6.2L	4 Spd, NP833 Trans (3 Spd w/OD), Iron Case Or Aluminum Case, 10 Bolt Side Cover, CORE REQUIRED, REBUILD AND RETURN ONLY, Use ATF	NP833O/D
1993-95	4.3L	4x2, 5 Spd, Getrag NV3500 Trans, GM# 1234539 Fluid Used, REBUILDABLE CORE REQUIRED, REBUILD AND RETURN ONLY, FRONT CASE MUST BE IN GOOD CONDITION	290-C				
1993-95	4.3L	4x2, 5 Spd, NV4500 Trans, W/Speedo, 6" Tail Housing, Cast Iron Case, Cast Iron Front Retainer, Code GAKF, Use GM# 12346190 Fluid	NV4500-C				
1993-95	4.3L	4x2, 5 Spd, NV4500 Trans, W/Speedo, With Parking Brake, Code GXW, Use GM# 12346190 Fluid	NV4500-I				
1989-92	4.3L	4x2, 5 Spd, Getrag NV3500 Trans, GM# 1234539 Fluid Used	290-B				
1989-91	4.3L	4x2, 4 Spd, SM465 Trans, Aluminum Top Cover With Electric Speedo, Use GM# 12345577 Fluid	SM465-H				

Pro King Manual Transmissions

YEAR	ENGINE	APPLICATION	PART NO.	YEAR	ENGINE	APPLICATION	PART NO.
GMC (cont.)				GMC (cont.)			
C1500 SIERRA XC				C1500 SIERRA XC (cont.)			
6 CYL				8 CYL (cont.)			
1997	4.3L	4x2, 5 Spd, NV4500 Trans, W/Speedo, Cast Iron Case, 6" Tail Housing, Flat Aluminum Front Retainer, Code GAMN, Use GM# 12346190 Fluid	NV4500-G	1993-95	5.0L, 5.7L	4x2, 5 Spd, NV4500 Trans, W/Speedo, 6" Tail Housing, Cast Iron Case, Cast Iron Front Retainer, Code GAKF, Use GM# 12346190 Fluid	NV4500-C
1997	4.3L	4x2, 5 Spd, NV4500 Trans, W/Speedo, Cast Iron Case, Flat Aluminum Front Retainer, 6" Tail Housing, Code GBBN, Use GM# 12346190 Fluid	NV4500-J	1993-95	5.0L, 5.7L, 6.2L, 6.5L	4x2, 5 Spd, Getrag NV3500 Trans, GM# 1234539 Fluid Used, REBUILDABLE CORE REQUIRED, REBUILD AND RETURN ONLY, FRONT CASE MUST BE IN GOOD CONDITION	290-C
1996-97	4.3L	4x2, 5 Spd, Getrag NV3500 Trans, Press in Speedo, GM# 1234539 Fluid Used, 15" Tail Housing, Alum. Case, Code GADT	290-E	1993-95	5.0L, 5.7L, 6.2L, 6.5L	4x2, 5 Spd, NV4500 Trans, W/Speedo, With Parking Brake, Code GXW, Use GM# 12346190 Fluid	NV4500-I
1993-95	4.3L	4x2, 5 Spd, Getrag NV3500 Trans, GM# 1234539 Fluid Used, REBUILDABLE CORE REQUIRED, REBUILD AND RETURN ONLY, FRONT CASE MUST BE IN GOOD CONDITION	290-C	1993-95	6.2L, 6.5L	4x2, 5 Spd, NV4500 Trans, W/Speedo, Without Parking Brake, Code GAKH, Use GM# 12346190 Fluid	NV4500-D
1993-95	4.3L	4x2, 5 Spd, NV4500 Trans, W/Speedo, 6" Tail Housing, Cast Iron Case, Cast Iron Front Retainer, Code GAKF, Use GM# 12346190 Fluid	NV4500-C	1989-92	5.0L, 5.7L, 6.2L	4x2, 5 Spd, Getrag NV3500 Trans, GM# 1234539 Fluid Used	290-B
1993-95	4.3L	4x2, 5 Spd, NV4500 Trans, W/Speedo, With Parking Brake, Code GXW, Use GM# 12346190 Fluid	NV4500-I	1989-91	5.0L, 5.7L, 6.2L	4x2, 4 Spd, SM465 Trans, Aluminum Top Cover With Electric Speedo, Use GM# 12345577 Fluid	SM465-H
1989-92	4.3L	4x2, 5 Spd, Getrag NV3500 Trans, GM# 1234539 Fluid Used	290-B	1989-91	5.0L, 5.7L, 6.2L	4x2, 4 Spd, SM465 Trans, Aluminum Top Cover With Mechanical Speedo, Use GM# 12345577 Fluid	SM465-G
1989-91	4.3L	4x2, 4 Spd, SM465 Trans, Aluminum Top Cover With Electric Speedo, Use GM# 12345577 Fluid	SM465-H	1989	5.0L, 5.7L, 6.2L	4 Spd, NP833 Trans (3 Spd w/OD), Iron Case Or Aluminum Case, 10 Bolt Side Cover, CORE REQUIRED, REBUILD AND RETURN ONLY, Use ATF	NP833O/D
1989-91	4.3L	4x2, 4 Spd, SM465 Trans, Aluminum Top Cover With Mechanical Speedo, Use GM# 12345577 Fluid	SM465-G	C25			
1989	4.3L	4 Spd, NP833 Trans (3 Spd w/OD), Iron Case Or Aluminum Case, 10 Bolt Side Cover, CORE REQUIRED, REBUILD AND RETURN ONLY, Use ATF	NP833O/D	6 CYL			
8 CYL				1975-78	4.1L, 4.8L	4x2, 4 Spd, SM465 Trans, With Tail Housing Mount, Use 80W90	SM465-B
1997	5.0L, 5.7L	4x2, 5 Spd, NV4500 Trans, W/Speedo, Cast Iron Case, 6" Tail Housing, Flat Aluminum Front Retainer, Code GAMN, Use GM# 12346190 Fluid	NV4500-G	8 CYL			
1997	5.0L, 5.7L, 6.5L	4x2, 5 Spd, NV4500 Trans, W/Speedo, Cast Iron Case, Flat Aluminum Front Retainer, 6" Tail Housing, Code GBBN, Use GM# 12346190 Fluid	NV4500-J	1975-78	5.0L, 5.7L, 6.6L, 7.4L	4x2, 4 Spd, SM465 Trans, With Tail Housing Mount, Use 80W90	SM465-B
1996-97	5.0L, 5.7L, 6.5L	4x2, 5 Spd, Getrag NV3500 Trans, Press in Speedo, GM# 1234539 Fluid Used, 15" Tail Housing, Alum. Case, Code GADT	290-E	C25 SUBURBAN			
8 CYL				6 CYL			
1997	5.0L, 5.7L, 6.5L	4x2, 5 Spd, NV4500 Trans, W/Speedo, Cast Iron Case, Flat Aluminum Front Retainer, 6" Tail Housing, Code GBBN, Use GM# 12346190 Fluid	NV4500-J	1975-78	4.8L	4x2, 4 Spd, SM465 Trans, With Tail Housing Mount, Use 80W90	SM465-B
1996-97	5.0L, 5.7L, 6.5L	4x2, 5 Spd, Getrag NV3500 Trans, Press in Speedo, GM# 1234539 Fluid Used, 15" Tail Housing, Alum. Case, Code GADT	290-E	8 CYL			
8 CYL				1975-78	5.0L, 5.7L, 6.6L, 7.4L	4x2, 4 Spd, SM465 Trans, With Tail Housing Mount, Use 80W90	SM465-B
1997	5.0L, 5.7L	4x2, 5 Spd, NV4500 Trans, W/Speedo, Cast Iron Case, 6" Tail Housing, Flat Aluminum Front Retainer, Code GAMN, Use GM# 12346190 Fluid	NV4500-G	C25/C2500 PICKUP & SUBURBAN			
1997	5.0L, 5.7L, 6.5L	4x2, 5 Spd, NV4500 Trans, W/Speedo, Cast Iron Case, Flat Aluminum Front Retainer, 6" Tail Housing, Code GBBN, Use GM# 12346190 Fluid	NV4500-J	6 CYL			
1996-97	5.0L, 5.7L, 6.5L	4x2, 5 Spd, Getrag NV3500 Trans, Press in Speedo, GM# 1234539 Fluid Used, 15" Tail Housing, Alum. Case, Code GADT	290-E	1984	4.8L	4 Spd, NP833 Trans (3 Spd w/OD), Iron Case Or Aluminum Case, 10 Bolt Side Cover, CORE REQUIRED, REBUILD AND RETURN ONLY, Use ATF	NP833O/D
8 CYL				1984	4.8L	4x2, 4 Spd, SM465 Trans, With Tail Housing Mount, Use 80W90	SM465-B

Pro King Manual Transmissions

YEAR	ENGINE	APPLICATION	PART NO.	YEAR	ENGINE	APPLICATION	PART NO.
GMC (cont.)				GMC (cont.)			
C25/C2500 PICKUP & SUBURBAN (cont.)				C2500 (cont.)			
6 CYL (cont.)				8 CYL (cont.)			
1981-82	4.8L	4 Spd, NP833 Trans (3 Spd w/OD), Iron Case Or Aluminum Case, 10 Bolt Side Cover, CORE REQUIRED, REBUILD AND RETURN ONLY, Use ATF	NP833O/D	1988	5.0L, 5.7L, 6.2L	4 Spd, NP833 Trans (3 Spd w/OD), Iron Case Or Aluminum Case, 10 Bolt Side Cover, CORE REQUIRED, REBUILD AND RETURN ONLY, Use ATF	NP833O/D
1979-82	4.8L	4x2, 4 Spd, SM465 Trans, With Tail Housing Mount, Use 80W90	SM465-B	1988	5.0L, 5.7L, 6.2L	4x2, 4 Spd, SM465 Trans, Aluminum Top Cover With Electric Speedo, Use GM# 12345577 Fluid	SM465-H
8 CYL				1988	5.0L, 5.7L, 6.2L	4x2, 4 Spd, SM465 Trans, Aluminum Top Cover With Mechanical Speedo, Use GM# 12345577 Fluid	SM465-G
1981-84	5.0L, 5.7L, 6.2L, 7.4L	4 Spd, NP833 Trans (3 Spd w/OD), Iron Case Or Aluminum Case, 10 Bolt Side Cover, CORE REQUIRED, REBUILD AND RETURN ONLY, Use ATF	NP833O/D	1988	5.0L, 5.7L, 6.2L	4x2, 5 Spd, Getrag NV3500 Trans, GM# 1234539 Fluid Used	290-B
1979-84	5.0L, 5.7L, 6.2L, 6.6L, 7.4L	4x2, 4 Spd, SM465 Trans, With Tail Housing Mount, Use 80W90	SM465-B	1986	5.0L, 5.7L, 6.2L, 7.4L	4 Spd, NP833 Trans (3 Spd w/OD), Iron Case Or Aluminum Case, 10 Bolt Side Cover, CORE REQUIRED, REBUILD AND RETURN ONLY, Use ATF	NP833O/D
C2500				C2500 SIERRA			
6 CYL				6 CYL			
1988	4.3L	4 Spd, NP833 Trans (3 Spd w/OD), Iron Case Or Aluminum Case, 10 Bolt Side Cover, CORE REQUIRED, REBUILD AND RETURN ONLY, Use ATF	NP833O/D	1981-84	5.0L, 5.7L, 6.2L, 7.4L	4 Spd, NP833 Trans (3 Spd w/OD), Iron Case Or Aluminum Case, 10 Bolt Side Cover, CORE REQUIRED, REBUILD AND RETURN ONLY, Use ATF	NP833O/D
1988	4.3L	4x2, 4 Spd, SM465 Trans, Aluminum Top Cover With Electric Speedo, Use GM# 12345577 Fluid	SM465-H	1979-86	5.0L, 5.7L, 6.2L, 6.6L, 7.4L	4x2, 4 Spd, SM465 Trans, With Tail Housing Mount, Use 80W90	SM465-B
1988	4.3L	4x2, 4 Spd, SM465 Trans, Aluminum Top Cover With Mechanical Speedo, Use GM# 12345577 Fluid	SM465-G	C2500 SIERRA			
1988	4.3L	4x2, 5 Spd, Getrag NV3500 Trans, GM# 1234539 Fluid Used	290-B	6 CYL			
1986	4.3L, 4.8L	4 Spd, NP833 Trans (3 Spd w/OD), Iron Case Or Aluminum Case, 10 Bolt Side Cover, CORE REQUIRED, REBUILD AND RETURN ONLY, Use ATF	NP833O/D	1993-95	4.3L	4x2, 5 Spd, Getrag NV3500 Trans, GM# 1234539 Fluid Used, REBUILDABLE CORE REQUIRED, REBUILD AND RETURN ONLY, FRONT CASE MUST BE IN GOOD CONDITION	290-C
1981-84	4.1L, 4.8L	4 Spd, NP833 Trans (3 Spd w/OD), Iron Case Or Aluminum Case, 10 Bolt Side Cover, CORE REQUIRED, REBUILD AND RETURN ONLY, Use ATF	NP833O/D	1993-95	4.3L	4x2, 5 Spd, NV4500 Trans, W/Speedo, 6" Tail Housing, Cast Iron Case, Cast Iron Front Retainer, Code GAKF, Use GM# 12346190 Fluid	NV4500-C
1979-86	4.1L, 4.3L, 4.8L	4x2, 4 Spd, SM465 Trans, With Tail Housing Mount, Use 80W90	SM465-B	1993-95	4.3L	4x2, 5 Spd, NV4500 Trans, W/Speedo, With Parking Brake, Code GXW, Use GM# 12346190 Fluid	NV4500-I
8 CYL				1989-92	4.3L	4x2, 5 Spd, Getrag NV3500 Trans, GM# 1234539 Fluid Used	290-B
1999-00	5.7L, 6.5L, 7.4L	4x2, 5 Spd, NV4500 Trans, W/Speedo, Cast Iron Case, Flat Aluminum Front Retainer, 6" Tail Housing, Code GBBN, Use GM# 12346190 Fluid	NV4500-J	1989-91	4.3L	4x2, 4 Spd, SM465 Trans, Aluminum Top Cover With Electric Speedo, Use GM# 12345577 Fluid	SM465-H
1999-00	5.7L, 7.4L	4x2, 5 Spd, NV4500 Trans, W/Speedo, Cast Iron Case, 6" Tail Housing, Flat Aluminum Front Retainer, Code GAMN, Use GM# 12346190 Fluid	NV4500-G	1989-91	4.3L	4x2, 4 Spd, SM465 Trans, Aluminum Top Cover With Mechanical Speedo, Use GM# 12345577 Fluid	SM465-G
				1989	4.3L	4 Spd, NP833 Trans (3 Spd w/OD), Iron Case Or Aluminum Case, 10 Bolt Side Cover, CORE REQUIRED, REBUILD AND RETURN ONLY, Use ATF	NP833O/D

Pro King Manual Transmissions

YEAR	ENGINE	APPLICATION	PART NO.	YEAR	ENGINE	APPLICATION	PART NO.
GMC (cont.)				GMC (cont.)			
C2500 SIERRA (cont.)				C2500 SIERRA XC (cont.)			
8 CYL				6 CYL (cont.)			
1997-98	5.0L, 5.7L, 6.5L, 7.4L	4x2, 5 Spd, NV4500 Trans, W/Speedo, Cast Iron Case, Flat Aluminum Front Retainer, 6" Tail Housing, Code GBBN, Use GM# 12346190 Fluid	NV4500-J	1989-92	4.3L	4x2, 5 Spd, Getrag NV3500 Trans, GM# 1234539 Fluid Used	290-B
1997-98	5.0L, 5.7L, 7.4L	4x2, 5 Spd, NV4500 Trans, W/Speedo, Cast Iron Case, 6" Tail Housing, Flat Aluminum Front Retainer, Code GAMN, Use GM# 12346190 Fluid	NV4500-G	1989-91	4.3L	4x2, 4 Spd, SM465 Trans, Aluminum Top Cover With Electric Speedo, Use GM# 12345577 Fluid	SM465-H
1996-98	5.7L	4x2, 5 Spd, Getrag NV3500 Trans, Press in Speedo, GM# 1234539 Fluid Used, 15" Tail Housing, Alum. Case, Code GADT	290-E	1989-91	4.3L	4x2, 4 Spd, SM465 Trans, Aluminum Top Cover With Mechanical Speedo, Use GM# 12345577 Fluid	SM465-G
1993-95	5.0L, 5.7L, 6.2L, 6.5L, 7.4L	4x2, 5 Spd, Getrag NV3500 Trans, GM# 1234539 Fluid Used, REBUILDABLE CORE REQUIRED, REBUILD AND RETURN ONLY, FRONT CASE MUST BE IN GOOD CONDITION	290-C	1989	4.3L	4 Spd, NP833 Trans (3 Spd w/OD), Iron Case Or Aluminum Case, 10 Bolt Side Cover, CORE REQUIRED, REBUILD AND RETURN ONLY, Use ATF	NP833O/D
1993-95	5.0L, 5.7L, 6.2L, 6.5L, 7.4L	4x2, 5 Spd, NV4500 Trans, W/Speedo, With Parking Brake, Code GXW, Use GM# 12346190 Fluid	NV4500-I	8 CYL			
1993-95	5.0L, 5.7L, 7.4L	4x2, 5 Spd, NV4500 Trans, W/Speedo, 6" Tail Housing, Cast Iron Case, Cast Iron Front Retainer, Code GAKF, Use GM# 12346190 Fluid	NV4500-C	1997-98	5.0L, 5.7L, 6.5L, 7.4L	4x2, 5 Spd, NV4500 Trans, W/Speedo, Cast Iron Case, Flat Aluminum Front Retainer, 6" Tail Housing, Code GBBN, Use GM# 12346190 Fluid	NV4500-J
1993-95	6.2L, 6.5L	4x2, 5 Spd, NV4500 Trans, W/Speedo, Without Parking Brake, Code GAKH, Use GM# 12346190 Fluid	NV4500-D	1997-98	5.0L, 5.7L, 7.4L	4x2, 5 Spd, NV4500 Trans, W/Speedo, Cast Iron Case, 6" Tail Housing, Flat Aluminum Front Retainer, Code GAMN, Use GM# 12346190 Fluid	NV4500-G
1989-92	5.0L, 5.7L, 6.2L, 6.5L, 7.4L	4x2, 5 Spd, Getrag NV3500 Trans, GM# 1234539 Fluid Used	290-B	1996-98	5.7L	4x2, 5 Spd, Getrag NV3500 Trans, Press in Speedo, GM# 1234539 Fluid Used, 15" Tail Housing, Alum. Case, Code GADT	290-E
1989-91	5.0L, 5.7L, 6.2L, 7.4L	4x2, 4 Spd, SM465 Trans, Aluminum Top Cover With Electric Speedo, Use GM# 12345577 Fluid	SM465-H	1993-95	5.0L, 5.7L, 6.2L, 6.5L, 7.4L	4x2, 5 Spd, Getrag NV3500 Trans, GM# 1234539 Fluid Used, REBUILDABLE CORE REQUIRED, REBUILD AND RETURN ONLY, FRONT CASE MUST BE IN GOOD CONDITION	290-C
1989-91	5.0L, 5.7L, 6.2L, 7.4L	4x2, 4 Spd, SM465 Trans, Aluminum Top Cover With Mechanical Speedo, Use GM# 12345577 Fluid	SM465-G	1993-95	5.0L, 5.7L, 6.2L, 6.5L, 7.4L	4x2, 5 Spd, NV4500 Trans, W/Speedo, With Parking Brake, Code GXW, Use GM# 12346190 Fluid	NV4500-I
1989	5.0L, 5.7L, 6.2L	4 Spd, NP833 Trans (3 Spd w/OD), Iron Case Or Aluminum Case, 10 Bolt Side Cover, CORE REQUIRED, REBUILD AND RETURN ONLY, Use ATF	NP833O/D	1993-95	5.0L, 5.7L, 7.4L	4x2, 5 Spd, NV4500 Trans, W/Speedo, 6" Tail Housing, Cast Iron Case, Cast Iron Front Retainer, Code GAKF, Use GM# 12346190 Fluid	NV4500-C
C2500 SIERRA XC				1993-95	6.2L, 6.5L	4x2, 5 Spd, NV4500 Trans, W/Speedo, Without Parking Brake, Code GAKH, Use GM# 12346190 Fluid	NV4500-D
6 CYL				1989-92	5.0L, 5.7L, 6.2L, 7.4L	4x2, 5 Spd, Getrag NV3500 Trans, GM# 1234539 Fluid Used	290-B
1993	4.3L	4x2, 5 Spd, Getrag NV3500 Trans, GM# 1234539 Fluid Used, REBUILDABLE CORE REQUIRED, REBUILD AND RETURN ONLY, FRONT CASE MUST BE IN GOOD CONDITION	290-C	1989-91	5.0L, 5.7L, 6.2L, 7.4L	4x2, 4 Spd, SM465 Trans, Aluminum Top Cover With Electric Speedo, Use GM# 12345577 Fluid	SM465-H
1993	4.3L	4x2, 5 Spd, NV4500 Trans, W/Speedo, 6" Tail Housing, Cast Iron Case, Cast Iron Front Retainer, Code GAKF, Use GM# 12346190 Fluid	NV4500-C	1989-91	5.0L, 5.7L, 6.2L, 7.4L	4x2, 4 Spd, SM465 Trans, Aluminum Top Cover With Mechanical Speedo, Use GM# 12345577 Fluid	SM465-G
1993	4.3L	4x2, 5 Spd, NV4500 Trans, W/Speedo, With Parking Brake, Code GXW, Use GM# 12346190 Fluid	NV4500-I	1989	5.0L, 5.7L, 6.2L	4 Spd, NP833 Trans (3 Spd w/OD), Iron Case Or Aluminum Case, 10 Bolt Side Cover, CORE REQUIRED, REBUILD AND RETURN ONLY, Use ATF	NP833O/D

Pro King Manual Transmissions

YEAR	ENGINE	APPLICATION	PART NO.	YEAR	ENGINE	APPLICATION	PART NO.
GMC (cont.)				GMC (cont.)			
C35				C3500 HD			
6 CYL				8 CYL			
1975-78	4.1L, 4.8L	4x2, 4 Spd, SM465 Trans, With Tail Housing Mount, Use 80W90	SM465-B	2001	6.5L	4x2, 5 Spd, NV4500 Trans, CORE REQUIRED, REBUILD AND RETURN ONLY, Use GM# 12346190 Fluid	NV4500-HA
8 CYL				2001	6.5L, 8.1L	4x2, 5 Spd, NV4500 Trans, W/Speedo, Cast Iron Case, Flat Aluminum Front Retainer, 6" Tail Housing, Code GBBN, Use GM# 12346190 Fluid	NV4500-J
1975-78	5.0L, 5.7L, 6.6L, 7.4L	4x2, 4 Spd, SM465 Trans, With Tail Housing Mount, Use 80W90	SM465-B	2001	8.1L	4x2, 5 Spd, NV4500 Trans, CORE REQUIRED, REBUILD AND RETURN ONLY, Use GM# 12346190 Fluid	NV4500-GA
C3500				C3500 HD CHASSIS CAB			
6 CYL				8 CYL			
1986	4.8L	4 Spd, NP833 Trans (3 Spd w/OD), Iron Case Or Aluminum Case, 10 Bolt Side Cover, CORE REQUIRED, REBUILD AND RETURN ONLY, Use ATF	NP833O/D	2002	6.5L	4x2, 5 Spd, NV4500 Trans, CORE REQUIRED, REBUILD AND RETURN ONLY, Use GM# 12346190 Fluid	NV4500-HA
1982-84	4.8L	4 Spd, NP833 Trans (3 Spd w/OD), Iron Case Or Aluminum Case, 10 Bolt Side Cover, CORE REQUIRED, REBUILD AND RETURN ONLY, Use ATF	NP833O/D	2002	6.5L, 8.1L	4x2, 5 Spd, NV4500 Trans, W/Speedo, Cast Iron Case, Flat Aluminum Front Retainer, 6" Tail Housing, Code GBBN, Use GM# 12346190 Fluid	NV4500-J
1979-86	4.1L, 4.8L	4x2, 4 Spd, SM465 Trans, With Tail Housing Mount, Use 80W90	SM465-B	2002	8.1L	4x2, 5 Spd, NV4500 Trans, CORE REQUIRED, REBUILD AND RETURN ONLY, Use GM# 12346190 Fluid	NV4500-GA
8 CYL				C3500 SIERRA			
1998-00	5.7L, 6.5L, 7.4L	4x2, 5 Spd, NV4500 Trans, W/Speedo, Cast Iron Case, Flat Aluminum Front Retainer, 6" Tail Housing, Code GBBN, Use GM# 12346190 Fluid	NV4500-J	8 CYL			
1998-00	5.7L, 7.4L	4x2, 5 Spd, NV4500 Trans, W/Speedo, Cast Iron Case, 6" Tail Housing, Flat Aluminum Front Retainer, Code GAMN, Use GM# 12346190 Fluid	NV4500-G	1996-97	5.7L, 6.5L, 7.4L	4x2, 5 Spd, NV4500 Trans, W/Speedo, Cast Iron Case, Flat Aluminum Front Retainer, 6" Tail Housing, Code GBBN, Use GM# 12346190 Fluid	NV4500-J
1988	5.7L, 6.2L, 7.4L	4 Spd, NP833 Trans (3 Spd w/OD), Iron Case Or Aluminum Case, 10 Bolt Side Cover, CORE REQUIRED, REBUILD AND RETURN ONLY, Use ATF	NP833O/D	1996-97	5.7L, 7.4L	4x2, 5 Spd, NV4500 Trans, W/Speedo, Cast Iron Case, 6" Tail Housing, Flat Aluminum Front Retainer, Code GAMN, Use GM# 12346190 Fluid	NV4500-G
1988	5.7L, 6.2L, 7.4L	4x2, 4 Spd, SM465 Trans, Aluminum Top Cover With Electric Speedo, Use GM# 12345577 Fluid	SM465-H	1992-95	5.7L, 6.2L, 6.5L, 7.4L	4x2, 5 Spd, NV4500 Trans, W/Speedo, With Parking Brake, Code GXW, Use GM# 12346190 Fluid	NV4500-I
1988	5.7L, 6.2L, 7.4L	4x2, 4 Spd, SM465 Trans, Aluminum Top Cover With Mechanical Speedo, Use GM# 12345577 Fluid	SM465-G	1992-95	5.7L, 7.4L	4x2, 5 Spd, NV4500 Trans, W/Speedo, 6" Tail Housing, Cast Iron Case, Cast Iron Front Retainer, Code GAKF, Use GM# 12346190 Fluid	NV4500-C
1988	5.7L, 6.2L, 7.4L	4x2, 5 Spd, Getrag NV3500 Trans, GM# 1234539 Fluid Used	290-B	1992-95	6.2L, 6.5L	4x2, 5 Spd, NV4500 Trans, W/Speedo, Without Parking Brake, Code GAKH, Use GM# 12346190 Fluid	NV4500-D
1986	5.0L, 5.7L, 6.2L, 7.4L	4 Spd, NP833 Trans (3 Spd w/OD), Iron Case Or Aluminum Case, 10 Bolt Side Cover, CORE REQUIRED, REBUILD AND RETURN ONLY, Use ATF	NP833O/D	1989-91	5.7L, 6.2L, 7.4L	4x2, 4 Spd, SM465 Trans, Aluminum Top Cover With Electric Speedo, Use GM# 12345577 Fluid	SM465-H
1982-84	5.7L, 6.2L, 7.4L	4 Spd, NP833 Trans (3 Spd w/OD), Iron Case Or Aluminum Case, 10 Bolt Side Cover, CORE REQUIRED, REBUILD AND RETURN ONLY, Use ATF	NP833O/D	1989-91	5.7L, 6.2L, 7.4L	4x2, 4 Spd, SM465 Trans, Aluminum Top Cover With Mechanical Speedo, Use GM# 12345577 Fluid	SM465-G
1979-86	5.0L, 5.7L, 6.2L, 6.6L, 7.4L	4x2, 4 Spd, SM465 Trans, With Tail Housing Mount, Use 80W90	SM465-B				

Pro King Manual Transmissions

YEAR	ENGINE	APPLICATION	PART NO.	YEAR	ENGINE	APPLICATION	PART NO.
GMC (cont.)				GMC (cont.)			
C3500 SIERRA (cont.)				G15 RALLY			
8 CYL (cont.)				6 CYL			
1989-91	5.7L, 6.2L, 7.4L	4x2, 5 Spd, Getrag NV3500 Trans, GM# 1234539 Fluid Used	290-B	1977-78	4.1L	4x2, 4 Spd, SM465 Trans, 10 Spine Output Shaft, No Threaded Holes In Case, Use 80W90	SM465-E
1989	5.7L, 6.2L, 7.4L	4 Spd, NP833 Trans (3 Spd w/OD), Iron Case Or Aluminum Case, 10 Bolt Side Cover, CORE REQUIRED, REBUILD AND RETURN ONLY, Use ATF	NP833O/D	1977-78	4.1L	4x2, 4 Spd, SM465 Trans, With Tail Housing Mount, Use 80W90	SM465-B
C3500 SIERRA XC				8 CYL			
8 CYL				6 CYL			
1996-97	5.7L, 6.5L, 7.4L	4x2, 5 Spd, NV4500 Trans, W/Speedo, Cast Iron Case, Flat Aluminum Front Retainer, 6" Tail Housing, Code GBBN, Use GM# 12346190 Fluid	NV4500-J	1975	4.1L	4x2, 4 Spd, SM465 Trans, 10 Spine Output Shaft, No Threaded Holes In Case, Use 80W90	SM465-E
1996-97	5.7L, 7.4L	4x2, 5 Spd, NV4500 Trans, W/Speedo, Cast Iron Case, 6" Tail Housing, Flat Aluminum Front Retainer, Code GAMN, Use GM# 12346190 Fluid	NV4500-G	1975	4.1L	4x2, 4 Spd, SM465 Trans, With Tail Housing Mount, Use 80W90	SM465-B
1992-95	5.7L, 6.2L, 6.5L, 7.4L	4x2, 5 Spd, NV4500 Trans, W/Speedo, With Parking Brake, Code GXW, Use GM# 12346190 Fluid	NV4500-I	G15 VANDURA			
1992-95	5.7L, 7.4L	4x2, 5 Spd, NV4500 Trans, W/Speedo, 6" Tail Housing, Cast Iron Case, Cast Iron Front Retainer, Code GAKF, Use GM# 12346190 Fluid	NV4500-C	6 CYL			
1992-95	6.2L, 6.5L	4x2, 5 Spd, NV4500 Trans, W/Speedo, Without Parking Brake, Code GAKH, Use GM# 12346190 Fluid	NV4500-D	1975-78	4.1L	4x2, 4 Spd, SM465 Trans, 10 Spine Output Shaft, No Threaded Holes In Case, Use 80W90	SM465-E
1989-91	5.7L, 6.2L, 7.4L	4x2, 4 Spd, SM465 Trans, Aluminum Top Cover With Electric Speedo, Use GM# 12345577 Fluid	SM465-H	1975-78	4.1L	4x2, 4 Spd, SM465 Trans, With Tail Housing Mount, Use 80W90	SM465-B
1989-91	5.7L, 6.2L, 7.4L	4x2, 4 Spd, SM465 Trans, Aluminum Top Cover With Mechanical Speedo, Use GM# 12345577 Fluid	SM465-G	8 CYL			
1989-91	5.7L, 6.2L, 7.4L	4x2, 5 Spd, Getrag NV3500 Trans, GM# 1234539 Fluid Used	290-B	1975-78	5.0L, 5.7L, 6.6L	4x2, 4 Spd, SM465 Trans, 10 Spine Output Shaft, No Threaded Holes In Case, Use 80W90	SM465-E
1989	5.7L, 6.2L, 7.4L	4 Spd, NP833 Trans (3 Spd w/OD), Iron Case Or Aluminum Case, 10 Bolt Side Cover, CORE REQUIRED, REBUILD AND RETURN ONLY, Use ATF	NP833O/D	1975-78	5.0L, 5.7L, 6.6L	4x2, 4 Spd, SM465 Trans, With Tail Housing Mount, Use 80W90	SM465-B
CABALLERO				G1500			
6 CYL				6 CYL			
1978-80	3.3L, 3.8L	4x2, 4 Spd, SM465 Trans, 10 Spine Output Shaft, No Threaded Holes In Case, Use 80W90	SM465-E	1983	4.1L	4 Spd, NP833 Trans (3 Spd w/OD), Iron Case Or Aluminum Case, 10 Bolt Side Cover, CORE REQUIRED, REBUILD AND RETURN ONLY, Use ATF	NP833O/D
1978-80	3.3L, 3.8L	4x2, 4 Spd, SM465 Trans, With Tail Housing Mount, Use 80W90	SM465-B	8 CYL			
8 CYL				G1500 RALLY			
1978-80	4.4L, 5.0L, 5.7L	4x2, 4 Spd, SM465 Trans, 10 Spine Output Shaft, No Threaded Holes In Case, Use 80W90	SM465-E	6 CYL			
1978-80	4.4L, 5.0L, 5.7L	4x2, 4 Spd, SM465 Trans, With Tail Housing Mount, Use 80W90	SM465-B	1988-90	4.3L	4x2, 5 Spd, Getrag NV3500 Trans, GM# 1234539 Fluid Used	290-B
8 CYL				1988-90	4.3L	4x4, 5 Spd, Getrag NV3500 Trans, No Speedo, GM# 1234539 Fluid Used, 14" Tail Housing	290-A
8 CYL				1988-89	4.3L	4x2, 4 Spd, SM465 Trans, Aluminum Top Cover With Electric Speedo, Use GM# 12345577 Fluid	SM465-H

Pro King Manual Transmissions

YEAR	ENGINE	APPLICATION	PART NO.	YEAR	ENGINE	APPLICATION	PART NO.
GMC (cont.)				GMC (cont.)			
G1500 RALLY (cont.)				G1500 RALLY (cont.)			
6 CYL (cont.)				8 CYL (cont.)			
1988-89	4.3L	4x2, 4 Spd, SM465 Trans, Aluminum Top Cover With Mechanical Speedo, Use GM# 12345577 Fluid	SM465-G	1985-87	5.0L, 5.7L	4x2, 4 Spd, SM465 Trans, 10 Spine Output Shaft, No Threaded Holes In Case, Use 80W90	SM465-E
1988-89	4.3L	4x4, 4 Spd, SM465 Trans, 32 Spine Output Shaft, Use GM# 12345577 Fluid	SM465-F	1985-87	5.0L, 5.7L	4x2, 4 Spd, SM465 Trans, With Tail Housing Mount, Use 80W90	SM465-B
1988-89	4.3L	4x4, 4 Spd, SM465 Trans, Aluminum Top Cover, Use GM# 12345577 Fluid	SM465-I	1985-87	5.0L, 5.7L	4x4, 4 Spd, SM465 Trans, 32 Spine Output Shaft, , Use 80W90	SM465-F
1986-89	4.3L	4 Spd, NP833 Trans (3 Spd w/OD), Iron Case Or Aluminum Case, 10 Bolt Side Cover, CORE REQUIRED, REBUILD AND RETURN ONLY, Use ATF	NP833O/D	1981-84	5.0L, 5.7L	4 Spd, NP833 Trans (3 Spd w/OD), Iron Case Or Aluminum Case, 10 Bolt Side Cover, CORE REQUIRED, REBUILD AND RETURN ONLY, Use ATF	NP833O/D
1985-87	4.3L	4x2, 4 Spd, SM465 Trans, 10 Spine Output Shaft, No Threaded Holes In Case, Use 80W90	SM465-E	1981-82	5.0L, 5.7L	4x4, 4 Spd, SM465 Trans, 32 Spine Output Shaft, , Use 80W90	SM465-F
1985-87	4.3L	4x2, 4 Spd, SM465 Trans, With Tail Housing Mount, Use 80W90	SM465-B	1979-82	5.0L, 5.7L, 6.6L	4x2, 4 Spd, SM465 Trans, 10 Spine Output Shaft, No Threaded Holes In Case, Use 80W90	SM465-E
1985-87	4.3L	4x4, 4 Spd, SM465 Trans, 32 Spine Output Shaft, , Use 80W90	SM465-F	1979-82	5.0L, 5.7L, 6.6L	4x2, 4 Spd, SM465 Trans, With Tail Housing Mount, Use 80W90	SM465-B
1981-84	4.1L	4 Spd, NP833 Trans (3 Spd w/OD), Iron Case Or Aluminum Case, 10 Bolt Side Cover, CORE REQUIRED, REBUILD AND RETURN ONLY, Use ATF	NP833O/D	G1500 VANDURA			
1981-82	4.1L	4x4, 4 Spd, SM465 Trans, 32 Spine Output Shaft, , Use 80W90	SM465-F	6 CYL			
1979-82	4.1L	4x2, 4 Spd, SM465 Trans, 10 Spine Output Shaft, No Threaded Holes In Case, Use 80W90	SM465-E	1988-90	4.3L	4x2, 5 Spd, Getrag NV3500 Trans, GM# 1234539 Fluid Used	290-B
1979-82	4.1L	4x2, 4 Spd, SM465 Trans, With Tail Housing Mount, Use 80W90	SM465-B	1988-90	4.3L	4x4, 5 Spd, Getrag NV3500 Trans, No Speedo, GM# 1234539 Fluid Used, 14" Tail Housing	290-A
8 CYL				1988-89	4.3L	4x2, 4 Spd, SM465 Trans, Aluminum Top Cover With Electric Speedo, Use GM# 12345577 Fluid	SM465-H
1988-90	5.0L, 5.7L	4x2, 5 Spd, Getrag NV3500 Trans, GM# 1234539 Fluid Used	290-B	1988-89	4.3L	4x2, 4 Spd, SM465 Trans, Aluminum Top Cover With Mechanical Speedo, Use GM# 12345577 Fluid	SM465-G
1988-90	5.0L, 5.7L	4x4, 5 Spd, Getrag NV3500 Trans, No Speedo, GM# 1234539 Fluid Used, 14" Tail Housing	290-A	1988-89	4.3L	4x4, 4 Spd, SM465 Trans, 32 Spine Output Shaft, Use GM# 12345577 Fluid	SM465-F
1988-89	5.0L, 5.7L	4x2, 4 Spd, SM465 Trans, Aluminum Top Cover With Electric Speedo, Use GM# 12345577 Fluid	SM465-H	1988-89	4.3L	4x4, 4 Spd, SM465 Trans, Aluminum Top Cover, Use GM# 12345577 Fluid	SM465-I
1988-89	5.0L, 5.7L	4x2, 4 Spd, SM465 Trans, Aluminum Top Cover With Mechanical Speedo, Use GM# 12345577 Fluid	SM465-G	1986-89	4.3L	4 Spd, NP833 Trans (3 Spd w/OD), Iron Case Or Aluminum Case, 10 Bolt Side Cover, CORE REQUIRED, REBUILD AND RETURN ONLY, Use ATF	NP833O/D
1988-89	5.0L, 5.7L	4x4, 4 Spd, SM465 Trans, 32 Spine Output Shaft, Use GM# 12345577 Fluid	SM465-F	1985-87	4.3L	4x2, 4 Spd, SM465 Trans, 10 Spine Output Shaft, No Threaded Holes In Case, Use 80W90	SM465-E
1988-89	5.0L, 5.7L	4x4, 4 Spd, SM465 Trans, Aluminum Top Cover, Use GM# 12345577 Fluid	SM465-I	1985-87	4.3L	4x2, 4 Spd, SM465 Trans, With Tail Housing Mount, Use 80W90	SM465-B
1986-89	5.0L, 5.7L	4 Spd, NP833 Trans (3 Spd w/OD), Iron Case Or Aluminum Case, 10 Bolt Side Cover, CORE REQUIRED, REBUILD AND RETURN ONLY, Use ATF	NP833O/D	1985-87	4.3L	4x4, 4 Spd, SM465 Trans, 32 Spine Output Shaft, , Use 80W90	SM465-F
				1981-84	4.1L	4 Spd, NP833 Trans (3 Spd w/OD), Iron Case Or Aluminum Case, 10 Bolt Side Cover, CORE REQUIRED, REBUILD AND RETURN ONLY, Use ATF	NP833O/D

Pro King Manual Transmissions

YEAR	ENGINE	APPLICATION	PART NO.	YEAR	ENGINE	APPLICATION	PART NO.
GMC (cont.)				GMC (cont.)			
G1500 VANDURA (cont.)				G25 RALLY (cont.)			
6 CYL (cont.)				6 CYL (cont.)			
1981-82	4.1L	4x4, 4 Spd, SM465 Trans, 32 Spine Output Shaft, , Use 80W90	SM465-F	1975-78	4.8L	4x2, 4 Spd, SM465 Trans, With Tail Housing Mount, Use 80W90	SM465-B
1979-82	4.1L	4x2, 4 Spd, SM465 Trans, 10 Spine Output Shaft, No Threaded Holes In Case, Use 80W90	SM465-E	8 CYL			
1979-82	4.1L	4x2, 4 Spd, SM465 Trans, With Tail Housing Mount, Use 80W90	SM465-B	1975-78	5.0L, 5.7L, 6.6L, 7.4L	4x2, 4 Spd, SM465 Trans, 10 Spine Output Shaft, No Threaded Holes In Case, Use 80W90	SM465-E
8 CYL				1975-78	5.0L, 5.7L, 6.6L, 7.4L	4x2, 4 Spd, SM465 Trans, With Tail Housing Mount, Use 80W90	SM465-B
1988-90	5.0L	4x2, 5 Spd, Getrag NV3500 Trans, GM# 1234539 Fluid Used	290-B	G25 VANDURA			
1988-90	5.0L	4x4, 5 Spd, Getrag NV3500 Trans, No Speedo, GM# 1234539 Fluid Used, 14" Tail Housing	290-A	6 CYL			
1988-89	5.0L	4x2, 4 Spd, SM465 Trans, Aluminum Top Cover With Electric Speedo, Use GM# 12345577 Fluid	SM465-H	1975-78	4.1L, 4.8L	4x2, 4 Spd, SM465 Trans, 10 Spine Output Shaft, No Threaded Holes In Case, Use 80W90	SM465-E
1988-89	5.0L	4x2, 4 Spd, SM465 Trans, Aluminum Top Cover With Mechanical Speedo, Use GM# 12345577 Fluid	SM465-G	1975-78	4.1L, 4.8L	4x2, 4 Spd, SM465 Trans, With Tail Housing Mount, Use 80W90	SM465-B
1988-89	5.0L	4x4, 4 Spd, SM465 Trans, 32 Spine Output Shaft, Use GM# 12345577 Fluid	SM465-F	8 CYL			
1988-89	5.0L	4x4, 4 Spd, SM465 Trans, Aluminum Top Cover, Use GM# 12345577 Fluid	SM465-I	1975-78	5.0L, 5.7L, 6.6L	4x2, 4 Spd, SM465 Trans, 10 Spine Output Shaft, No Threaded Holes In Case, Use 80W90	SM465-E
1986-89	5.0L	4 Spd, NP833 Trans (3 Spd w/OD), Iron Case Or Aluminum Case, 10 Bolt Side Cover, CORE REQUIRED, REBUILD AND RETURN ONLY, Use ATF	NP833O/D	1975-78	5.0L, 5.7L, 6.6L	4x2, 4 Spd, SM465 Trans, With Tail Housing Mount, Use 80W90	SM465-B
1985-87	5.0L	4x2, 4 Spd, SM465 Trans, 10 Spine Output Shaft, No Threaded Holes In Case, Use 80W90	SM465-E	G2500 RALLY			
1985-87	5.0L	4x2, 4 Spd, SM465 Trans, With Tail Housing Mount, Use 80W90	SM465-B	6 CYL			
1985-87	5.0L	4x4, 4 Spd, SM465 Trans, 32 Spine Output Shaft, , Use 80W90	SM465-F	1988-90	4.3L	4x2, 5 Spd, Getrag NV3500 Trans, GM# 1234539 Fluid Used	290-B
1981-84	5.0L, 5.7L	4 Spd, NP833 Trans (3 Spd w/OD), Iron Case Or Aluminum Case, 10 Bolt Side Cover, CORE REQUIRED, REBUILD AND RETURN ONLY, Use ATF	NP833O/D	1988-90	4.3L	4x4, 5 Spd, Getrag NV3500 Trans, No Speedo, GM# 1234539 Fluid Used, 14" Tail Housing	290-A
1981-82	5.0L, 5.7L	4x4, 4 Spd, SM465 Trans, 32 Spine Output Shaft, , Use 80W90	SM465-F	1988-89	4.3L	4x2, 4 Spd, SM465 Trans, Aluminum Top Cover With Electric Speedo, Use GM# 12345577 Fluid	SM465-H
1979-82	5.0L, 5.7L	4x2, 4 Spd, SM465 Trans, 10 Spine Output Shaft, No Threaded Holes In Case, Use 80W90	SM465-E	1988-89	4.3L	4x2, 4 Spd, SM465 Trans, Aluminum Top Cover With Mechanical Speedo, Use GM# 12345577 Fluid	SM465-G
1979-82	5.0L, 5.7L	4x2, 4 Spd, SM465 Trans, With Tail Housing Mount, Use 80W90	SM465-B	1988-89	4.3L	4x4, 4 Spd, SM465 Trans, 32 Spine Output Shaft, Use GM# 12345577 Fluid	SM465-F
G25 RALLY				1988-89	4.3L	4x4, 4 Spd, SM465 Trans, Aluminum Top Cover, Use GM# 12345577 Fluid	SM465-I
6 CYL				1986-89	4.3L	4 Spd, NP833 Trans (3 Spd w/OD), Iron Case Or Aluminum Case, 10 Bolt Side Cover, CORE REQUIRED, REBUILD AND RETURN ONLY, Use ATF	NP833O/D
1975-78	4.8L	4x2, 4 Spd, SM465 Trans, 10 Spine Output Shaft, No Threaded Holes In Case, Use 80W90	SM465-E	1985-87	4.3L	4x2, 4 Spd, SM465 Trans, 10 Spine Output Shaft, No Threaded Holes In Case, Use 80W90	SM465-E
G25 RALLY				1985-87	4.3L	4x2, 4 Spd, SM465 Trans, With Tail Housing Mount, Use 80W90	SM465-B
6 CYL				1985-87	4.3L	4x4, 4 Spd, SM465 Trans, 32 Spine Output Shaft, , Use 80W90	SM465-F

Pro King Manual Transmissions

YEAR	ENGINE	APPLICATION	PART NO.	YEAR	ENGINE	APPLICATION	PART NO.
GMC (cont.)				GMC (cont.)			
G2500 RALLY (cont.)				G2500 VANDURA			
6 CYL (cont.)				6 CYL			
1981-84	4.1L	4 Spd, NP833 Trans (3 Spd w/OD), Iron Case Or Aluminum Case, 10 Bolt Side Cover, CORE REQUIRED, REBUILD AND RETURN ONLY, Use ATF	NP833O/D	1988-90	4.3L	4x2, 5 Spd, Getrag NV3500 Trans, GM# 1234539 Fluid Used	290-B
1981-82	4.1L	4x4, 4 Spd, SM465 Trans, 32 Spine Output Shaft, , Use 80W90	SM465-F	1988-90	4.3L	4x4, 5 Spd, Getrag NV3500 Trans, No Speedo, GM# 1234539 Fluid Used, 14" Tail Housing	290-A
1979-82	4.1L	4x2, 4 Spd, SM465 Trans, 10 Spine Output Shaft, No Threaded Holes In Case, Use 80W90	SM465-E	1988-89	4.3L	4x2, 4 Spd, SM465 Trans, Aluminum Top Cover With Electric Speedo, Use GM# 12345577 Fluid	SM465-H
1979-82	4.1L	4x2, 4 Spd, SM465 Trans, With Tail Housing Mount, Use 80W90	SM465-B	1988-89	4.3L	4x2, 4 Spd, SM465 Trans, Aluminum Top Cover With Mechanical Speedo, Use GM# 12345577 Fluid	SM465-G
8 CYL				1988-89	4.3L	4x4, 4 Spd, SM465 Trans, 32 Spine Output Shaft, Use GM# 12345577 Fluid	SM465-F
1988-90	5.0L, 5.7L, 6.2L	4x2, 5 Spd, Getrag NV3500 Trans, GM# 1234539 Fluid Used	290-B	1988-89	4.3L	4x4, 4 Spd, SM465 Trans, Aluminum Top Cover, Use GM# 12345577 Fluid	SM465-I
1988-90	5.0L, 5.7L, 6.2L	4x4, 5 Spd, Getrag NV3500 Trans, No Speedo, GM# 1234539 Fluid Used, 14" Tail Housing	290-A	1986-89	4.3L	4 Spd, NP833 Trans (3 Spd w/OD), Iron Case Or Aluminum Case, 10 Bolt Side Cover, CORE REQUIRED, REBUILD AND RETURN ONLY, Use ATF	NP833O/D
1988-89	5.0L, 5.7L, 6.2L	4x2, 4 Spd, SM465 Trans, Aluminum Top Cover With Electric Speedo, Use GM# 12345577 Fluid	SM465-H	1985-87	4.3L	4x2, 4 Spd, SM465 Trans, 10 Spine Output Shaft, No Threaded Holes In Case, Use 80W90	SM465-E
1988-89	5.0L, 5.7L, 6.2L	4x2, 4 Spd, SM465 Trans, Aluminum Top Cover With Mechanical Speedo, Use GM# 12345577 Fluid	SM465-G	1985-87	4.3L	4x2, 4 Spd, SM465 Trans, With Tail Housing Mount, Use 80W90	SM465-B
1988-89	5.0L, 5.7L, 6.2L	4x4, 4 Spd, SM465 Trans, 32 Spine Output Shaft, Use GM# 12345577 Fluid	SM465-F	1985-87	4.3L	4x4, 4 Spd, SM465 Trans, 32 Spine Output Shaft, , Use 80W90	SM465-F
1988-89	5.0L, 5.7L, 6.2L	4x4, 4 Spd, SM465 Trans, Aluminum Top Cover, Use GM# 12345577 Fluid	SM465-I	1981-84	4.1L	4 Spd, NP833 Trans (3 Spd w/OD), Iron Case Or Aluminum Case, 10 Bolt Side Cover, CORE REQUIRED, REBUILD AND RETURN ONLY, Use ATF	NP833O/D
1986-89	5.0L, 5.7L, 6.2L	4 Spd, NP833 Trans (3 Spd w/OD), Iron Case Or Aluminum Case, 10 Bolt Side Cover, CORE REQUIRED, REBUILD AND RETURN ONLY, Use ATF	NP833O/D	1981-82	4.1L	4x4, 4 Spd, SM465 Trans, 32 Spine Output Shaft, , Use 80W90	SM465-F
1985-87	5.0L, 5.7L, 6.2L	4x2, 4 Spd, SM465 Trans, 10 Spine Output Shaft, No Threaded Holes In Case, Use 80W90	SM465-E	1979-82	4.1L	4x2, 4 Spd, SM465 Trans, 10 Spine Output Shaft, No Threaded Holes In Case, Use 80W90	SM465-E
1985-87	5.0L, 5.7L, 6.2L	4x2, 4 Spd, SM465 Trans, With Tail Housing Mount, Use 80W90	SM465-B	1979-82	4.1L	4x2, 4 Spd, SM465 Trans, With Tail Housing Mount, Use 80W90	SM465-B
1985-87	5.0L, 5.7L, 6.2L	4x4, 4 Spd, SM465 Trans, 32 Spine Output Shaft, , Use 80W90	SM465-F	8 CYL			
1981-84	5.0L, 5.7L, 6.2L	4 Spd, NP833 Trans (3 Spd w/OD), Iron Case Or Aluminum Case, 10 Bolt Side Cover, CORE REQUIRED, REBUILD AND RETURN ONLY, Use ATF	NP833O/D	1988-90	5.0L, 5.7L, 6.2L	4x2, 5 Spd, Getrag NV3500 Trans, GM# 1234539 Fluid Used	290-B
1981-82	5.0L, 5.7L	4x4, 4 Spd, SM465 Trans, 32 Spine Output Shaft, , Use 80W90	SM465-F	1988-90	5.0L, 5.7L, 6.2L	4x4, 5 Spd, Getrag NV3500 Trans, No Speedo, GM# 1234539 Fluid Used, 14" Tail Housing	290-A
1979-82	5.0L, 5.7L, 6.6L	4x2, 4 Spd, SM465 Trans, 10 Spine Output Shaft, No Threaded Holes In Case, Use 80W90	SM465-E	1988-89	5.0L, 5.7L, 6.2L	4x2, 4 Spd, SM465 Trans, Aluminum Top Cover With Electric Speedo, Use GM# 12345577 Fluid	SM465-H
1979-82	5.0L, 5.7L, 6.6L	4x2, 4 Spd, SM465 Trans, With Tail Housing Mount, Use 80W90	SM465-B	1988-89	5.0L, 5.7L, 6.2L	4x2, 4 Spd, SM465 Trans, Aluminum Top Cover With Mechanical Speedo, Use GM# 12345577 Fluid	SM465-G
				1988-89	5.0L, 5.7L, 6.2L	4x4, 4 Spd, SM465 Trans, 32 Spine Output Shaft, Use GM# 12345577 Fluid	SM465-F

Pro King Manual Transmissions

YEAR	ENGINE	APPLICATION	PART NO.	YEAR	ENGINE	APPLICATION	PART NO.
GMC (cont.)				GMC (cont.)			
G2500 VANDURA (cont.)				G35 VANDURA			
8 CYL (cont.)				6 CYL			
1988-89	5.0L, 5.7L, 6.2L	4x4, 4 Spd, SM465 Trans, Aluminum Top Cover, Use GM# 12345577 Fluid	SM465-I	1976-78	4.1L, 4.8L	4x2, 4 Spd, SM465 Trans, 10 Spine Output Shaft, No Threaded Holes In Case, Use 80W90	SM465-E
1986-89	5.0L, 5.7L, 6.2L	4 Spd, NP833 Trans (3 Spd w/OD), Iron Case Or Aluminum Case, 10 Bolt Side Cover, CORE REQUIRED, REBUILD AND RETURN ONLY, Use ATF	NP833O/D	1976-78	4.1L, 4.8L	4x2, 4 Spd, SM465 Trans, With Tail Housing Mount, Use 80W90	SM465-B
1985-87	5.0L, 5.7L, 6.2L	4x2, 4 Spd, SM465 Trans, 10 Spine Output Shaft, No Threaded Holes In Case, Use 80W90	SM465-E	8 CYL			
1985-87	5.0L, 5.7L, 6.2L	4x2, 4 Spd, SM465 Trans, With Tail Housing Mount, Use 80W90	SM465-B	1975-78	5.7L, 6.6L	4x2, 4 Spd, SM465 Trans, 10 Spine Output Shaft, No Threaded Holes In Case, Use 80W90	SM465-E
1985-87	5.0L, 5.7L, 6.2L	4x4, 4 Spd, SM465 Trans, 32 Spine Output Shaft, , Use 80W90	SM465-F	1975-78	5.7L, 6.6L	4x2, 4 Spd, SM465 Trans, With Tail Housing Mount, Use 80W90	SM465-B
1981-84	5.0L, 5.7L, 6.2L	4 Spd, NP833 Trans (3 Spd w/OD), Iron Case Or Aluminum Case, 10 Bolt Side Cover, CORE REQUIRED, REBUILD AND RETURN ONLY, Use ATF	NP833O/D	G3500			
1981-82	5.0L, 5.7L	4x4, 4 Spd, SM465 Trans, 32 Spine Output Shaft, , Use 80W90	SM465-F	8 CYL			
1979-82	5.0L, 5.7L, 6.6L	4x2, 4 Spd, SM465 Trans, 10 Spine Output Shaft, No Threaded Holes In Case, Use 80W90	SM465-E	1988-90	5.7L, 6.2L, 7.4L	4x2, 5 Spd, Getrag NV3500 Trans, GM# 1234539 Fluid Used	290-B
1979-82	5.0L, 5.7L, 6.6L	4x2, 4 Spd, SM465 Trans, With Tail Housing Mount, Use 80W90	SM465-B	1988-90	5.7L, 6.2L, 7.4L	4x4, 5 Spd, Getrag NV3500 Trans, No Speedo, GM# 1234539 Fluid Used, 14" Tail Housing	290-A
G35				1982-84	5.7L, 6.2L	4 Spd, NP833 Trans (3 Spd w/OD), Iron Case Or Aluminum Case, 10 Bolt Side Cover, CORE REQUIRED, REBUILD AND RETURN ONLY, Use ATF	NP833O/D
6 CYL				1981-82	5.7L	4x4, 4 Spd, SM465 Trans, 32 Spine Output Shaft, , Use 80W90	SM465-F
1975-78	4.8L	4x2, 4 Spd, SM465 Trans, 10 Spine Output Shaft, No Threaded Holes In Case, Use 80W90	SM465-E	1979-82	5.7L, 6.6L	4x2, 4 Spd, SM465 Trans, 10 Spine Output Shaft, No Threaded Holes In Case, Use 80W90	SM465-E
1975-78	4.8L	4x2, 4 Spd, SM465 Trans, With Tail Housing Mount, Use 80W90	SM465-B	1979-82	5.7L, 6.6L	4x2, 4 Spd, SM465 Trans, With Tail Housing Mount, Use 80W90	SM465-B
8 CYL				G3500 RALLY			
1975-78	5.7L, 6.6L, 7.4L	4x2, 4 Spd, SM465 Trans, 10 Spine Output Shaft, No Threaded Holes In Case, Use 80W90	SM465-E	8 CYL			
1975-78	5.7L, 6.6L, 7.4L	4x2, 4 Spd, SM465 Trans, With Tail Housing Mount, Use 80W90	SM465-B	1988-90	5.7L, 6.2L, 7.4L	4x2, 5 Spd, Getrag NV3500 Trans, GM# 1234539 Fluid Used	290-B
G35 RALLY				1988-90	5.7L, 6.2L, 7.4L	4x4, 5 Spd, Getrag NV3500 Trans, No Speedo, GM# 1234539 Fluid Used, 14" Tail Housing	290-A
6 CYL				1982-84	5.7L, 6.2L	4 Spd, NP833 Trans (3 Spd w/OD), Iron Case Or Aluminum Case, 10 Bolt Side Cover, CORE REQUIRED, REBUILD AND RETURN ONLY, Use ATF	NP833O/D
1976-78	4.8L	4x2, 4 Spd, SM465 Trans, 10 Spine Output Shaft, No Threaded Holes In Case, Use 80W90	SM465-E	1981-82	5.7L	4x4, 4 Spd, SM465 Trans, 32 Spine Output Shaft, , Use 80W90	SM465-F
1976-78	4.8L	4x2, 4 Spd, SM465 Trans, With Tail Housing Mount, Use 80W90	SM465-B	1979-82	5.7L, 6.6L	4x2, 4 Spd, SM465 Trans, 10 Spine Output Shaft, No Threaded Holes In Case, Use 80W90	SM465-E
8 CYL				1979-82	5.7L, 6.6L	4x2, 4 Spd, SM465 Trans, With Tail Housing Mount, Use 80W90	SM465-B
1975-78	5.7L, 6.6L	4x2, 4 Spd, SM465 Trans, 10 Spine Output Shaft, No Threaded Holes In Case, Use 80W90	SM465-E				
1975-78	5.7L, 6.6L	4x2, 4 Spd, SM465 Trans, With Tail Housing Mount, Use 80W90	SM465-B				

Pro King Manual Transmissions

YEAR	ENGINE	APPLICATION	PART NO.	YEAR	ENGINE	APPLICATION	PART NO.
GMC (cont.)				GMC (cont.)			
G3500 VANDURA				JIMMY (cont.)			
6 CYL				6 CYL (cont.)			
1988-90	4.3L	4x2, 5 Spd, Getrag NV3500 Trans, GM# 1234539 Fluid Used	290-B	1996-00	4.3L	4x4, 5 Spd, Getrag NV3500 Trans, CORE REQUIRED, REBUILD AND RETURN ONLY, No Speedo, GM# 1234539 Fluid Used, 14" Tail Housing, Code GADU	290-D
1988-90	4.3L	4x4, 5 Spd, Getrag NV3500 Trans, No Speedo, GM# 1234539 Fluid Used, 14" Tail Housing	290-A	1995	4.3L	4x2, 5 Spd, Getrag NV3500 Trans, GM# 1234539 Fluid Used, REBUILDABLE CORE REQUIRED, REBUILD AND RETURN ONLY, FRONT CASE MUST BE IN GOOD CONDITION	290-C
1982-84	4.1L	4 Spd, NP833 Trans (3 Spd w/OD), Iron Case Or Aluminum Case, 10 Bolt Side Cover, CORE REQUIRED, REBUILD AND RETURN ONLY, Use ATF	NP833O/D	1995	4.3L	4x4, 5 Spd, Getrag NV3500 Trans, No Speedo, GM# 1234539 Fluid Used, 14" Tail Housing Code GZA, REBUILDABLE CORE REQUIRED, REBUILD AND RETURN ONLY, FRONT CASE MUST BE IN GOOD CONDITION	290-AB
1982	4.1L	4x2, 4 Spd, SM465 Trans, 10 Spine Output Shaft, No Threaded Holes In Case, Use 80W90	SM465-E	1981-82	4.1L	4 Spd, NP833 Trans (3 Spd w/OD), Iron Case Or Aluminum Case, 10 Bolt Side Cover, CORE REQUIRED, REBUILD AND RETURN ONLY, Use ATF	NP833O/D
1982	4.1L	4x2, 4 Spd, SM465 Trans, With Tail Housing Mount, Use 80W90	SM465-B	1981-82	4.1L	4x4, 4 Spd, SM465 Trans, 32 Spine Output Shaft, , Use 80W90	SM465-F
1982	4.1L	4x4, 4 Spd, SM465 Trans, 32 Spine Output Shaft, , Use 80W90	SM465-F	1975-82	4.1L	4x2, 4 Spd, SM465 Trans, 10 Spine Output Shaft, No Threaded Holes In Case, Use 80W90	SM465-E
1979	4.1L	4x2, 4 Spd, SM465 Trans, 10 Spine Output Shaft, No Threaded Holes In Case, Use 80W90	SM465-E	1975-82	4.1L	4x2, 4 Spd, SM465 Trans, With Tail Housing Mount, Use 80W90	SM465-B
1979	4.1L	4x2, 4 Spd, SM465 Trans, With Tail Housing Mount, Use 80W90	SM465-B	8 CYL			
8 CYL				1988-91	5.7L, 6.2L	4x2, 4 Spd, SM465 Trans, Aluminum Top Cover With Electric Speedo, Use GM# 12345577 Fluid	SM465-H
1988-90	5.7L, 6.2L, 7.4L	4x2, 5 Spd, Getrag NV3500 Trans, GM# 1234539 Fluid Used	290-B	1988-91	5.7L, 6.2L	4x2, 4 Spd, SM465 Trans, Aluminum Top Cover With Mechanical Speedo, Use GM# 12345577 Fluid	SM465-G
1988-90	5.7L, 6.2L, 7.4L	4x4, 5 Spd, Getrag NV3500 Trans, No Speedo, GM# 1234539 Fluid Used, 14" Tail Housing	290-A	1988-91	5.7L, 6.2L	4x2, 5 Spd, Getrag NV3500 Trans, GM# 1234539 Fluid Used	290-B
1982-84	5.7L, 6.2L	4 Spd, NP833 Trans (3 Spd w/OD), Iron Case Or Aluminum Case, 10 Bolt Side Cover, CORE REQUIRED, REBUILD AND RETURN ONLY, Use ATF	NP833O/D	1988-91	5.7L, 6.2L	4x4, 4 Spd, SM465 Trans, 32 Spine Output Shaft, Use GM# 12345577 Fluid	SM465-F
1981-82	5.0L, 5.7L	4x4, 4 Spd, SM465 Trans, 32 Spine Output Shaft, , Use 80W90	SM465-F	1988-91	5.7L, 6.2L	4x4, 4 Spd, SM465 Trans, Aluminum Top Cover, Use GM# 12345577 Fluid	SM465-I
1979-82	5.0L, 5.7L, 6.6L	4x2, 4 Spd, SM465 Trans, 10 Spine Output Shaft, No Threaded Holes In Case, Use 80W90	SM465-E	1988-91	5.7L, 6.2L	4x4, 5 Spd, Getrag NV3500 Trans, No Speedo, GM# 1234539 Fluid Used, 14" Tail Housing	290-A
1979-82	5.0L, 5.7L, 6.6L	4x2, 4 Spd, SM465 Trans, With Tail Housing Mount, Use 80W90	SM465-B	1986-88	5.0L, 5.7L, 6.2L	4 Spd, NP833 Trans (3 Spd w/OD), Iron Case Or Aluminum Case, 10 Bolt Side Cover, CORE REQUIRED, REBUILD AND RETURN ONLY, Use ATF	NP833O/D
JIMMY				1981-87	5.0L, 5.7L, 6.2L	4x4, 4 Spd, SM465 Trans, 32 Spine Output Shaft, , Use 80W90	SM465-F
6 CYL							
2001	4.3L	4x2, 5 Spd, Getrag NV3500 Trans, Electric Speedo Screw in, GM# 1234539 Fluid Used, 18.5" Tail Housing, Alum. Case, Code GBDX	290-J				
1996-00	4.3L	4x2, 5 Spd, Getrag NV3500 Trans, Press in Speedo, GM# 1234539 Fluid Used, 15" Tail Housing, Alum. Case, Code GADT	290-E				

Pro King Manual Transmissions

YEAR	ENGINE	APPLICATION	PART NO.	YEAR	ENGINE	APPLICATION	PART NO.
GMC (cont.)				GMC (cont.)			
JIMMY (cont.)				K1500 (cont.)			
8 CYL (cont.)				6 CYL (cont.)			
1981-84	5.0L, 5.7L, 6.2L	4 Spd, NP833 Trans (3 Spd w/OD), Iron Case Or Aluminum Case, 10 Bolt Side Cover, CORE REQUIRED, REBUILD AND RETURN ONLY, Use ATF	NP833O/D	1988	4.3L	4x4, 4 Spd, SM465 Trans, Aluminum Top Cover, Use GM# 12345577 Fluid	SM465-I
1975-87	5.0L, 5.7L, 6.2L, 6.6L, 7.4L	4x2, 4 Spd, SM465 Trans, 10 Spine Output Shaft, No Threaded Holes In Case, Use 80W90	SM465-E	1988	4.3L	4x4, 5 Spd, Getrag NV3500 Trans, No Speedo, GM# 1234539 Fluid Used, 14" Tail Housing	290-A
1975-87	5.0L, 5.7L, 6.2L, 6.6L, 7.4L	4x2, 4 Spd, SM465 Trans, With Tail Housing Mount, Use 80W90	SM465-B	1986	4.3L	4 Spd, NP833 Trans (3 Spd w/OD), Iron Case Or Aluminum Case, 10 Bolt Side Cover, CORE REQUIRED, REBUILD AND RETURN ONLY, Use ATF	NP833O/D
K15				1981-86	4.1L, 4.3L	4x4, 4 Spd, SM465 Trans, 32 Spine Output Shaft, , Use 80W90	SM465-F
6 CYL				1981-84	4.1L	4 Spd, NP833 Trans (3 Spd w/OD), Iron Case Or Aluminum Case, 10 Bolt Side Cover, CORE REQUIRED, REBUILD AND RETURN ONLY, Use ATF	NP833O/D
1975-78	4.1L, 4.8L	4x2, 4 Spd, SM465 Trans, 10 Spine Output Shaft, No Threaded Holes In Case, Use 80W90	SM465-E	1979-86	4.1L, 4.3L, 4.8L	4x2, 4 Spd, SM465 Trans, 10 Spine Output Shaft, No Threaded Holes In Case, Use 80W90	SM465-E
8 CYL				8 CYL			
1975-78	5.0L, 5.7L, 6.6L, 7.4L	4x2, 4 Spd, SM465 Trans, 10 Spine Output Shaft, No Threaded Holes In Case, Use 80W90	SM465-E	1988	5.0L, 5.7L, 6.2L	4 Spd, NP833 Trans (3 Spd w/OD), Iron Case Or Aluminum Case, 10 Bolt Side Cover, CORE REQUIRED, REBUILD AND RETURN ONLY, Use ATF	NP833O/D
K15 SUBURBAN				1988	5.0L, 5.7L, 6.2L	4x4, 4 Spd, SM465 Trans, 32 Spine Output Shaft, Use GM# 12345577 Fluid	SM465-F
6 CYL				1988	5.0L, 5.7L, 6.2L	4x4, 4 Spd, SM465 Trans, Aluminum Top Cover, Use GM# 12345577 Fluid	SM465-I
1975-78	4.1L	4x2, 4 Spd, SM465 Trans, 10 Spine Output Shaft, No Threaded Holes In Case, Use 80W90	SM465-E	1988	5.0L, 5.7L, 6.2L	4x4, 5 Spd, Getrag NV3500 Trans, No Speedo, GM# 1234539 Fluid Used, 14" Tail Housing	290-A
8 CYL				1986	5.0L, 5.7L, 6.2L	4 Spd, NP833 Trans (3 Spd w/OD), Iron Case Or Aluminum Case, 10 Bolt Side Cover, CORE REQUIRED, REBUILD AND RETURN ONLY, Use ATF	NP833O/D
1975-78	5.0L, 5.7L, 6.6L	4x2, 4 Spd, SM465 Trans, 10 Spine Output Shaft, No Threaded Holes In Case, Use 80W90	SM465-E	1981-86	5.0L, 5.7L, 6.2L	4x4, 4 Spd, SM465 Trans, 32 Spine Output Shaft, , Use 80W90	SM465-F
K15/K1500 PICKUP & SUBURBAN				1981-84	5.0L, 5.7L, 6.2L	4 Spd, NP833 Trans (3 Spd w/OD), Iron Case Or Aluminum Case, 10 Bolt Side Cover, CORE REQUIRED, REBUILD AND RETURN ONLY, Use ATF	NP833O/D
6 CYL				1981-84	5.0L, 5.7L, 6.2L	4x4, 4 Spd, SM465 Trans, 32 Spine Output Shaft, , Use 80W90	SM465-F
1979-80	4.1L	4x2, 4 Spd, SM465 Trans, 10 Spine Output Shaft, No Threaded Holes In Case, Use 80W90	SM465-E	1979-84	5.0L, 5.7L, 6.2L, 6.6L	4x2, 4 Spd, SM465 Trans, 10 Spine Output Shaft, No Threaded Holes In Case, Use 80W90	SM465-E
8 CYL				K1500			
1981-84	5.0L, 5.7L, 6.2L	4 Spd, NP833 Trans (3 Spd w/OD), Iron Case Or Aluminum Case, 10 Bolt Side Cover, CORE REQUIRED, REBUILD AND RETURN ONLY, Use ATF	NP833O/D	6 CYL			
1981-84	5.0L, 5.7L, 6.2L	4x4, 4 Spd, SM465 Trans, 32 Spine Output Shaft, , Use 80W90	SM465-F	1988	4.3L	4 Spd, NP833 Trans (3 Spd w/OD), Iron Case Or Aluminum Case, 10 Bolt Side Cover, CORE REQUIRED, REBUILD AND RETURN ONLY, Use ATF	NP833O/D
1979-84	5.0L, 5.7L, 6.2L, 6.6L	4x2, 4 Spd, SM465 Trans, 10 Spine Output Shaft, No Threaded Holes In Case, Use 80W90	SM465-E	1988	4.3L	4x4, 4 Spd, SM465 Trans, 32 Spine Output Shaft, Use GM# 12345577 Fluid	SM465-F
K1500				K1500 SIERRA			
6 CYL				6 CYL			
1988	4.3L	4 Spd, NP833 Trans (3 Spd w/OD), Iron Case Or Aluminum Case, 10 Bolt Side Cover, CORE REQUIRED, REBUILD AND RETURN ONLY, Use ATF	NP833O/D	1997-98	4.3L	4x4, 5 Spd, NV4500 Trans, No Speedo, Cast Iron Case, Flat Aluminum Front Retainer, Code GARH, Use GM# 12346190 Fluid	NV4500-E

Pro King Manual Transmissions

YEAR	ENGINE	APPLICATION	PART NO.	YEAR	ENGINE	APPLICATION	PART NO.
GMC (cont.)				GMC (cont.)			
K1500 SIERRA (cont.)				K1500 SIERRA (cont.)			
6 CYL (cont.)				8 CYL (cont.)			
1996-98	4.3L	4x4, 5 Spd, Getrag NV3500 Trans, CORE REQUIRED, REBUILD AND RETURN ONLY, No Speedo, GM# 1234539 Fluid Used, 14" Tail Housing, Code GADU	290-D	1989-92	5.0L, 5.7L, 6.2L	4x4, 5 Spd, Getrag NV3500 Trans, No Speedo, GM# 1234539 Fluid Used, 14" Tail Housing	290-A
1993-95	4.3L	4x4, 5 Spd, NV4500 Trans, No Speedo, Cast Iron Case, Cast Iron Front Retainer, Code GAKD, Use GM# 12346190 Fluid	NV4500-A	1989-91	5.0L, 5.7L, 6.2L	4x4, 4 Spd, SM465 Trans, 32 Spine Output Shaft, Use GM# 12345577 Fluid	SM465-F
1993-94	4.3L	4x4, 5 Spd, Getrag NV3500 Trans, No Speedo, GM# 1234539 Fluid Used, 14" Tail Housing Code GZA, REBUILDABLE CORE REQUIRED, REBUILD AND RETURN ONLY, FRONT CASE MUST BE IN GOOD CONDITION	290-AB	1989-91	5.0L, 5.7L, 6.2L	4x4, 4 Spd, SM465 Trans, Aluminum Top Cover, Use GM# 12345577 Fluid	SM465-I
1989-92	4.3L	4x4, 5 Spd, Getrag NV3500 Trans, No Speedo, GM# 1234539 Fluid Used, 14" Tail Housing	290-A	1989	5.0L, 5.7L, 6.2L	4 Spd, NP833 Trans (3 Spd w/OD), Iron Case Or Aluminum Case, 10 Bolt Side Cover, CORE REQUIRED, REBUILD AND RETURN ONLY, Use ATF	NP833O/D
1989-91	4.3L	4x4, 4 Spd, SM465 Trans, 32 Spine Output Shaft, Use GM# 12345577 Fluid	SM465-F	K1500 SIERRA XC			
1989-91	4.3L	4x4, 4 Spd, SM465 Trans, Aluminum Top Cover, Use GM# 12345577 Fluid	SM465-I	6 CYL			
1989	4.3L	4 Spd, NP833 Trans (3 Spd w/OD), Iron Case Or Aluminum Case, 10 Bolt Side Cover, CORE REQUIRED, REBUILD AND RETURN ONLY, Use ATF	NP833O/D	1997-98	4.3L	4x4, 5 Spd, NV4500 Trans, No Speedo, Cast Iron Case, Flat Aluminum Front Retainer, Code GARH, Use GM# 12346190 Fluid	NV4500-E
8 CYL				1996-98	4.3L	4x4, 5 Spd, Getrag NV3500 Trans, CORE REQUIRED, REBUILD AND RETURN ONLY, No Speedo, GM# 1234539 Fluid Used, 14" Tail Housing, Code GADU	290-D
1998	6.5L	4x4, 5 Spd, NV4500 Trans, No Speedo, Cast Iron Case, Flat Aluminum Front Retainer, Code GAWN, Use GM# 12346190 Fluid	NV4500-F	1993-95	4.3L	4x4, 5 Spd, NV4500 Trans, No Speedo, Cast Iron Case, Cast Iron Front Retainer, Code GAKD, Use GM# 12346190 Fluid	NV4500-A
1997-98	5.0L, 5.7L	4x4, 5 Spd, NV4500 Trans, No Speedo, Cast Iron Case, Flat Aluminum Front Retainer, Code GARH, Use GM# 12346190 Fluid	NV4500-E	1993-94	4.3L	4x4, 5 Spd, Getrag NV3500 Trans, No Speedo, GM# 1234539 Fluid Used, 14" Tail Housing Code GZA, REBUILDABLE CORE REQUIRED, REBUILD AND RETURN ONLY, FRONT CASE MUST BE IN GOOD CONDITION	290-AB
1996-98	5.0L, 5.7L, 6.5L	4x4, 5 Spd, Getrag NV3500 Trans, CORE REQUIRED, REBUILD AND RETURN ONLY, No Speedo, GM# 1234539 Fluid Used, 14" Tail Housing, Code GADU	290-D	1989-92	4.3L	4x4, 5 Spd, Getrag NV3500 Trans, No Speedo, GM# 1234539 Fluid Used, 14" Tail Housing	290-A
1993-95	5.0L, 5.7L	4x4, 5 Spd, NV4500 Trans, No Speedo, Cast Iron Case, Cast Iron Front Retainer, Code GAKD, Use GM# 12346190 Fluid	NV4500-A	1989-91	4.3L	4x4, 4 Spd, SM465 Trans, 32 Spine Output Shaft, Use GM# 12345577 Fluid	SM465-F
1993-95	6.2L, 6.5L	4x4, 5 Spd, NV4500 Trans, No Speedo, Cast Iron Case, Cast Iron Front Retainer, Code GAKK, Use GM# 12346190 Fluid	NV4500-B	1989-91	4.3L	4x4, 4 Spd, SM465 Trans, Aluminum Top Cover, Use GM# 12345577 Fluid	SM465-I
1993-94	5.0L, 5.7L, 6.2L, 6.5L	4x4, 5 Spd, Getrag NV3500 Trans, No Speedo, GM# 1234539 Fluid Used, 14" Tail Housing Code GZA, REBUILDABLE CORE REQUIRED, REBUILD AND RETURN ONLY, FRONT CASE MUST BE IN GOOD CONDITION	290-AB	1989	4.3L	4 Spd, NP833 Trans (3 Spd w/OD), Iron Case Or Aluminum Case, 10 Bolt Side Cover, CORE REQUIRED, REBUILD AND RETURN ONLY, Use ATF	NP833O/D
				8 CYL			
				1997-98	5.0L, 5.7L	4x4, 5 Spd, NV4500 Trans, No Speedo, Cast Iron Case, Flat Aluminum Front Retainer, Code GARH, Use GM# 12346190 Fluid	NV4500-E
				1997-98	6.5L	4x4, 5 Spd, NV4500 Trans, No Speedo, Cast Iron Case, Flat Aluminum Front Retainer, Code GAWN, Use GM# 12346190 Fluid	NV4500-F

Pro King Manual Transmissions

YEAR	ENGINE	APPLICATION	PART NO.	YEAR	ENGINE	APPLICATION	PART NO.
GMC (cont.)				GMC (cont.)			
K1500 SIERRA XC (cont.)				K25/K2500 PICKUP & SUBURBAN			
8 CYL (cont.)				6 CYL			
1996-98	5.0L, 5.7L, 6.5L	4x4, 5 Spd, Getrag NV3500 Trans, CORE REQUIRED, REBUILD AND RETURN ONLY, No Speedo, GM# 1234539 Fluid Used, 14" Tail Housing, Code GADU	290-D	1984	4.8L	4 Spd, NP833 Trans (3 Spd w/OD), Iron Case Or Aluminum Case, 10 Bolt Side Cover, CORE REQUIRED, REBUILD AND RETURN ONLY, Use ATF	NP833O/D
1993-95	5.0L, 5.7L	4x4, 5 Spd, NV4500 Trans, No Speedo, Cast Iron Case, Cast Iron Front Retainer, Code GAKD, Use GM# 12346190 Fluid	NV4500-A	1984	4.8L	4x2, 4 Spd, SM465 Trans, 32 Spine Output Shaft, No Threaded Holes In Case, Use 80W90	SM465-E
1993-95	6.2L, 6.5L	4x4, 5 Spd, NV4500 Trans, No Speedo, Cast Iron Case, Cast Iron Front Retainer, Code GAKK, Use GM# 12346190 Fluid	NV4500-B	1984	4.8L	4x4, 4 Spd, SM465 Trans, 32 Spine Output Shaft, , Use 80W90	SM465-F
1993-94	5.0L, 5.7L, 6.2L, 6.5L	4x4, 5 Spd, Getrag NV3500 Trans, No Speedo, GM# 1234539 Fluid Used, 14" Tail Housing Code GZA, REBUILDABLE CORE REQUIRED, REBUILD AND RETURN ONLY, FRONT CASE MUST BE IN GOOD CONDITION	290-AB	1981-82	4.8L	4 Spd, NP833 Trans (3 Spd w/OD), Iron Case Or Aluminum Case, 10 Bolt Side Cover, CORE REQUIRED, REBUILD AND RETURN ONLY, Use ATF	NP833O/D
1989-92	5.0L, 5.7L, 6.2L	4x4, 5 Spd, Getrag NV3500 Trans, No Speedo, GM# 1234539 Fluid Used, 14" Tail Housing	290-A	1981-82	4.8L	4x4, 4 Spd, SM465 Trans, 32 Spine Output Shaft, , Use 80W90	SM465-F
1989-91	5.0L, 5.7L, 6.2L	4x4, 4 Spd, SM465 Trans, 32 Spine Output Shaft, Use GM# 12345577 Fluid	SM465-F	1979-82	4.8L	4x2, 4 Spd, SM465 Trans, 10 Spine Output Shaft, No Threaded Holes In Case, Use 80W90	SM465-E
1989-91	5.0L, 5.7L, 6.2L	4x4, 4 Spd, SM465 Trans, Aluminum Top Cover, Use GM# 12345577 Fluid	SM465-I	8 CYL			
1989	5.0L, 5.7L, 6.2L	4 Spd, NP833 Trans (3 Spd w/OD), Iron Case Or Aluminum Case, 10 Bolt Side Cover, CORE REQUIRED, REBUILD AND RETURN ONLY, Use ATF	NP833O/D	1981-84	5.7L, 6.2L	4 Spd, NP833 Trans (3 Spd w/OD), Iron Case Or Aluminum Case, 10 Bolt Side Cover, CORE REQUIRED, REBUILD AND RETURN ONLY, Use ATF	NP833O/D
K25				K2500			
6 CYL				6 CYL			
1975-78	4.1L, 4.8L	4x2, 4 Spd, SM465 Trans, 10 Spine Output Shaft, No Threaded Holes In Case, Use 80W90	SM465-E	1988	4.3L	4 Spd, NP833 Trans (3 Spd w/OD), Iron Case Or Aluminum Case, 10 Bolt Side Cover, CORE REQUIRED, REBUILD AND RETURN ONLY, Use ATF	NP833O/D
8 CYL				1988	4.3L	4x4, 4 Spd, SM465 Trans, 32 Spine Output Shaft, Use GM# 12345577 Fluid	SM465-F
1975-78	5.0L, 5.7L, 6.6L, 7.4L	4x2, 4 Spd, SM465 Trans, 10 Spine Output Shaft, No Threaded Holes In Case, Use 80W90	SM465-E	1988	4.3L	4x4, 4 Spd, SM465 Trans, Aluminum Top Cover, Use GM# 12345577 Fluid	SM465-I
K25 SUBURBAN				1988	4.3L	4x4, 5 Spd, Getrag NV3500 Trans, No Speedo, GM# 1234539 Fluid Used, 14" Tail Housing	290-A
6 CYL				1986	4.8L	4 Spd, NP833 Trans (3 Spd w/OD), Iron Case Or Aluminum Case, 10 Bolt Side Cover, CORE REQUIRED, REBUILD AND RETURN ONLY, Use ATF	NP833O/D
1975-78	4.8L	4x2, 4 Spd, SM465 Trans, 10 Spine Output Shaft, No Threaded Holes In Case, Use 80W90	SM465-E	1981-86	4.3L, 4.8L	4x4, 4 Spd, SM465 Trans, 32 Spine Output Shaft, , Use 80W90	SM465-F
8 CYL							
1975-78	5.0L, 5.7L, 6.6L, 7.4L	4x2, 4 Spd, SM465 Trans, 10 Spine Output Shaft, No Threaded Holes In Case, Use 80W90	SM465-E				

Pro King Manual Transmissions

YEAR	ENGINE	APPLICATION	PART NO.	YEAR	ENGINE	APPLICATION	PART NO.
GMC (cont.)				GMC (cont.)			
K2500 (cont.)				K2500 SIERRA			
6 CYL (cont.)				6 CYL			
1981-84	4.8L	4 Spd, NP833 Trans (3 Spd w/OD), Iron Case Or Aluminum Case, 10 Bolt Side Cover, CORE REQUIRED, REBUILD AND RETURN ONLY, Use ATF	NP833O/D	1993-95	4.3L	4x4, 5 Spd, Getrag NV3500 Trans, No Speedo, GM# 1234539 Fluid Used, 14" Tail Housing Code GZA, REBUILDABLE CORE REQUIRED, REBUILD AND RETURN ONLY, FRONT CASE MUST BE IN GOOD CONDITION	290-AB
1979-86	4.1L, 4.3L, 4.8L	4x2, 4 Spd, SM465 Trans, 10 Spine Output Shaft, No Threaded Holes In Case, Use 80W90	SM465-E	1993-95	4.3L	4x4, 5 Spd, NV4500 Trans, No Speedo, Cast Iron Case, Cast Iron Front Retainer, Code GAKD, Use GM# 12346190 Fluid	NV4500-A
8 CYL				8 CYL			
1998-00	5.0L, 5.7L, 7.4L	4x4, 5 Spd, NV4500 Trans, No Speedo, Cast Iron Case, Flat Aluminum Front Retainer, Code GARH, Use GM# 12346190 Fluid	NV4500-E	1989-92	4.3L	4x4, 5 Spd, Getrag NV3500 Trans, No Speedo, GM# 1234539 Fluid Used, 14" Tail Housing	290-A
1998-00	6.5L	4x4, 5 Spd, NV4500 Trans, No Speedo, Cast Iron Case, Flat Aluminum Front Retainer, Code GAWN, Use GM# 12346190 Fluid	NV4500-F	1989-91	4.3L	4x4, 4 Spd, SM465 Trans, 32 Spine Output Shaft, Use GM# 12345577 Fluid	SM465-F
1998	5.7L	4x4, 5 Spd, Getrag NV3500 Trans, CORE REQUIRED, REBUILD AND RETURN ONLY, No Speedo, GM# 1234539 Fluid Used, 14" Tail Housing, Code GADU	290-D	1989-91	4.3L	4x4, 4 Spd, SM465 Trans, Aluminum Top Cover, Use GM# 12345577 Fluid	SM465-I
1988	5.0L, 5.7L, 6.2L	4 Spd, NP833 Trans (3 Spd w/OD), Iron Case Or Aluminum Case, 10 Bolt Side Cover, CORE REQUIRED, REBUILD AND RETURN ONLY, Use ATF	NP833O/D	1989	4.3L	4 Spd, NP833 Trans (3 Spd w/OD), Iron Case Or Aluminum Case, 10 Bolt Side Cover, CORE REQUIRED, REBUILD AND RETURN ONLY, Use ATF	NP833O/D
1988	5.0L, 5.7L, 6.2L	4x4, 4 Spd, SM465 Trans, 32 Spine Output Shaft, Use GM# 12345577 Fluid	SM465-F	8 CYL			
1988	5.0L, 5.7L, 6.2L	4x4, 4 Spd, SM465 Trans, Aluminum Top Cover, Use GM# 12345577 Fluid	SM465-I	1997	5.7L, 7.4L	4x4, 5 Spd, NV4500 Trans, No Speedo, Cast Iron Case, Flat Aluminum Front Retainer, Code GARH, Use GM# 12346190 Fluid	NV4500-E
1988	5.0L, 5.7L, 6.2L	4x4, 5 Spd, Getrag NV3500 Trans, No Speedo, GM# 1234539 Fluid Used, 14" Tail Housing	290-A	1997	6.5L	4x4, 5 Spd, NV4500 Trans, No Speedo, Cast Iron Case, Flat Aluminum Front Retainer, Code GAWN, Use GM# 12346190 Fluid	NV4500-F
1986	5.7L, 6.2L	4 Spd, NP833 Trans (3 Spd w/OD), Iron Case Or Aluminum Case, 10 Bolt Side Cover, CORE REQUIRED, REBUILD AND RETURN ONLY, Use ATF	NP833O/D	1996-97	5.7L	4x4, 5 Spd, Getrag NV3500 Trans, CORE REQUIRED, REBUILD AND RETURN ONLY, No Speedo, GM# 1234539 Fluid Used, 14" Tail Housing, Code GADU	290-D
1981-86	5.7L, 6.2L	4x4, 4 Spd, SM465 Trans, 32 Spine Output Shaft, Use 80W90	SM465-F	1993-95	5.0L, 5.7L, 6.2L, 6.5L, 7.4L	4x4, 5 Spd, Getrag NV3500 Trans, No Speedo, GM# 1234539 Fluid Used, 14" Tail Housing Code GZA, REBUILDABLE CORE REQUIRED, REBUILD AND RETURN ONLY, FRONT CASE MUST BE IN GOOD CONDITION	290-AB
1981-84	5.7L, 6.2L	4 Spd, NP833 Trans (3 Spd w/OD), Iron Case Or Aluminum Case, 10 Bolt Side Cover, CORE REQUIRED, REBUILD AND RETURN ONLY, Use ATF	NP833O/D	1993-95	5.0L, 5.7L, 7.4L	4x4, 5 Spd, NV4500 Trans, No Speedo, Cast Iron Case, Cast Iron Front Retainer, Code GAKD, Use GM# 12346190 Fluid	NV4500-A
1979-86	5.7L, 6.2L, 6.6L	4x2, 4 Spd, SM465 Trans, 10 Spine Output Shaft, No Threaded Holes In Case, Use 80W90	SM465-E	1993-95	6.2L, 6.5L	4x4, 5 Spd, NV4500 Trans, No Speedo, Cast Iron Case, Cast Iron Front Retainer, Code GAKK, Use GM# 12346190 Fluid	NV4500-B
				1989-92	5.0L, 5.7L, 6.2L, 6.5L, 7.4L	4x4, 5 Spd, Getrag NV3500 Trans, No Speedo, GM# 1234539 Fluid Used, 14" Tail Housing	290-A

Pro King Manual Transmissions

YEAR	ENGINE	APPLICATION	PART NO.	YEAR	ENGINE	APPLICATION	PART NO.
GMC (cont.)				GMC (cont.)			
K2500 SIERRA (cont.)				K2500 SIERRA XC (cont.)			
8 CYL (cont.)				8 CYL (cont.)			
1989-91	5.0L, 5.7L, 6.2L, 7.4L	4x4, 4 Spd, SM465 Trans, 32 Spine Output Shaft, Use GM# 12345577 Fluid	SM465-F	1993-95	5.0L, 5.7L, 7.4L	4x4, 5 Spd, NV4500 Trans, No Speedo, Cast Iron Case, Cast Iron Front Retainer, Code GAKD, Use GM# 12346190 Fluid	NV4500-A
1989-91	5.0L, 5.7L, 6.2L, 7.4L	4x4, 4 Spd, SM465 Trans, Aluminum Top Cover, Use GM# 12345577 Fluid	SM465-I	1993-95	6.2L, 6.5L	4x4, 5 Spd, NV4500 Trans, No Speedo, Cast Iron Case, Cast Iron Front Retainer, Code GAKK, Use GM# 12346190 Fluid	NV4500-B
1989	5.0L, 5.7L, 6.2L	4 Spd, NP833 Trans (3 Spd w/OD), Iron Case Or Aluminum Case, 10 Bolt Side Cover, CORE REQUIRED, REBUILD AND RETURN ONLY, Use ATF	NP833O/D	1989-92	5.0L, 5.7L, 6.2L, 6.5L, 7.4L	4x4, 5 Spd, Getrag NV3500 Trans, No Speedo, GM# 1234539 Fluid Used, 14" Tail Housing	290-A
K2500 SIERRA XC				K35			
6 CYL				6 CYL			
1993	4.3L	4x4, 5 Spd, Getrag NV3500 Trans, No Speedo, GM# 1234539 Fluid Used, 14" Tail Housing Code GZA, REBUILDABLE CORE REQUIRED, REBUILD AND RETURN ONLY, FRONT CASE MUST BE IN GOOD CONDITION	290-AB	1977-78	4.8L	4x2, 4 Spd, SM465 Trans, 10 Spine Output Shaft, No Threaded Holes In Case, Use 80W90	SM465-E
1993	4.3L	4x4, 5 Spd, NV4500 Trans, No Speedo, Cast Iron Case, Cast Iron Front Retainer, Code GAKD, Use GM# 12346190 Fluid	NV4500-A	8 CYL			
1989-92	4.3L	4x4, 5 Spd, Getrag NV3500 Trans, No Speedo, GM# 1234539 Fluid Used, 14" Tail Housing	290-A	1977-78	5.7L, 6.6L	4x2, 4 Spd, SM465 Trans, 10 Spine Output Shaft, No Threaded Holes In Case, Use 80W90	SM465-E
1989-91	4.3L	4x4, 4 Spd, SM465 Trans, 32 Spine Output Shaft, Use GM# 12345577 Fluid	SM465-F	K3500			
1989-91	4.3L	4x4, 4 Spd, SM465 Trans, Aluminum Top Cover, Use GM# 12345577 Fluid	SM465-I	6 CYL			
1989	4.3L	4 Spd, NP833 Trans (3 Spd w/OD), Iron Case Or Aluminum Case, 10 Bolt Side Cover, CORE REQUIRED, REBUILD AND RETURN ONLY, Use ATF	NP833O/D	1986	4.8L	4 Spd, NP833 Trans (3 Spd w/OD), Iron Case Or Aluminum Case, 10 Bolt Side Cover, CORE REQUIRED, REBUILD AND RETURN ONLY, Use ATF	NP833O/D
8 CYL				1982-84	4.8L	4 Spd, NP833 Trans (3 Spd w/OD), Iron Case Or Aluminum Case, 10 Bolt Side Cover, CORE REQUIRED, REBUILD AND RETURN ONLY, Use ATF	NP833O/D
1997	5.7L, 7.4L	4x4, 5 Spd, NV4500 Trans, No Speedo, Cast Iron Case, Flat Aluminum Front Retainer, Code GARH, Use GM# 12346190 Fluid	NV4500-E	1981-86	4.8L	4x4, 4 Spd, SM465 Trans, 32 Spine Output Shaft, Use 80W90	SM465-F
1997	6.5L	4x4, 5 Spd, NV4500 Trans, No Speedo, Cast Iron Case, Flat Aluminum Front Retainer, Code GAWN, Use GM# 12346190 Fluid	NV4500-F	1979-86	4.8L	4x2, 4 Spd, SM465 Trans, 10 Spine Output Shaft, No Threaded Holes In Case, Use 80W90	SM465-E
1996-97	5.7L	4x4, 5 Spd, Getrag NV3500 Trans, CORE REQUIRED, REBUILD AND RETURN ONLY, No Speedo, GM# 1234539 Fluid Used, 14" Tail Housing, Code GADU	290-D	8 CYL			
1993-95	5.0L, 5.7L, 6.2L, 6.5L, 7.4L	4x4, 5 Spd, Getrag NV3500 Trans, No Speedo, GM# 1234539 Fluid Used, 14" Tail Housing Code GZA, REBUILDABLE CORE REQUIRED, REBUILD AND RETURN ONLY, FRONT CASE MUST BE IN GOOD CONDITION	290-AB	1998-00	6.5L	4x4, 5 Spd, NV4500 Trans, No Speedo, Cast Iron Case, Flat Aluminum Front Retainer, Code GAWN, Use GM# 12346190 Fluid	NV4500-F

Pro King Manual Transmissions

YEAR	ENGINE	APPLICATION	PART NO.	YEAR	ENGINE	APPLICATION	PART NO.
GMC (cont.)				GMC (cont.)			
K3500 (cont.)				K3500 SIERRA (cont.)			
8 CYL (cont.)				8 CYL (cont.)			
1988	5.7L, 6.2L, 7.4L	4 Spd, NP833 Trans (3 Spd w/OD), Iron Case Or Aluminum Case, 10 Bolt Side Cover, CORE REQUIRED, REBUILD AND RETURN ONLY, Use ATF	NP833O/D	1989	5.7L, 6.2L, 7.4L	4 Spd, NP833 Trans (3 Spd w/OD), Iron Case Or Aluminum Case, 10 Bolt Side Cover, CORE REQUIRED, REBUILD AND RETURN ONLY, Use ATF	NP833O/D
1988	5.7L, 6.2L, 7.4L	4x4, 4 Spd, SM465 Trans, 32 Spine Output Shaft, Use GM# 12345577 Fluid	SM465-F	K3500 SIERRA XC			
1988	5.7L, 6.2L, 7.4L	4x4, 4 Spd, SM465 Trans, Aluminum Top Cover, Use GM# 12345577 Fluid	SM465-I	8 CYL			
1988	5.7L, 6.2L, 7.4L	4x4, 5 Spd, Getrag NV3500 Trans, No Speedo, GM# 1234539 Fluid Used, 14" Tail Housing	290-A	1996-97	5.7L, 7.4L	4x4, 5 Spd, NV4500 Trans, No Speedo, Cast Iron Case, Flat Aluminum Front Retainer, Code GARH, Use GM# 12346190 Fluid	NV4500-E
1986	5.7L, 6.2L, 7.4L	4 Spd, NP833 Trans (3 Spd w/OD), Iron Case Or Aluminum Case, 10 Bolt Side Cover, CORE REQUIRED, REBUILD AND RETURN ONLY, Use ATF	NP833O/D	1996-97	6.5L	4x4, 5 Spd, NV4500 Trans, No Speedo, Cast Iron Case, Flat Aluminum Front Retainer, Code GAWN, Use GM# 12346190 Fluid	NV4500-F
1982-84	5.7L, 6.2L, 7.4L	4 Spd, NP833 Trans (3 Spd w/OD), Iron Case Or Aluminum Case, 10 Bolt Side Cover, CORE REQUIRED, REBUILD AND RETURN ONLY, Use ATF	NP833O/D	1992-95	5.7L, 7.4L	4x4, 5 Spd, NV4500 Trans, No Speedo, Cast Iron Case, Cast Iron Front Retainer, Code GAKD, Use GM# 12346190 Fluid	NV4500-A
1981-86	5.7L, 6.2L, 7.4L	4x4, 4 Spd, SM465 Trans, 32 Spine Output Shaft, Use 80W90	SM465-F	1992-95	6.2L, 6.5L	4x4, 5 Spd, NV4500 Trans, No Speedo, Cast Iron Case, Cast Iron Front Retainer, Code GAKK, Use GM# 12346190 Fluid	NV4500-B
1979-86	5.7L, 6.2L, 6.6L, 7.4L	4x2, 4 Spd, SM465 Trans, 10 Spine Output Shaft, No Threaded Holes In Case, Use 80W90	SM465-E	1989-91	5.7L, 6.2L, 7.4L	4x4, 4 Spd, SM465 Trans, 32 Spine Output Shaft, Use GM# 12345577 Fluid	SM465-F
K3500 SIERRA				1989-91	5.7L, 6.2L, 7.4L	4x4, 4 Spd, SM465 Trans, Aluminum Top Cover, Use GM# 12345577 Fluid	SM465-I
8 CYL				1989-91	5.7L, 6.2L, 7.4L	4x4, 5 Spd, Getrag NV3500 Trans, No Speedo, GM# 1234539 Fluid Used, 14" Tail Housing	290-A
1996-97	5.7L, 7.4L	4x4, 5 Spd, NV4500 Trans, No Speedo, Cast Iron Case, Flat Aluminum Front Retainer, Code GARH, Use GM# 12346190 Fluid	NV4500-E	1989	5.7L, 6.2L, 7.4L	4 Spd, NP833 Trans (3 Spd w/OD), Iron Case Or Aluminum Case, 10 Bolt Side Cover, CORE REQUIRED, REBUILD AND RETURN ONLY, Use ATF	NP833O/D
1996-97	6.5L	4x4, 5 Spd, NV4500 Trans, No Speedo, Cast Iron Case, Flat Aluminum Front Retainer, Code GAWN, Use GM# 12346190 Fluid	NV4500-F	P15			
1992-95	5.7L, 7.4L	4x4, 5 Spd, NV4500 Trans, No Speedo, Cast Iron Case, Cast Iron Front Retainer, Code GAKD, Use GM# 12346190 Fluid	NV4500-A	6 CYL			
1992-95	6.2L, 6.5L	4x4, 5 Spd, NV4500 Trans, No Speedo, Cast Iron Case, Cast Iron Front Retainer, Code GAKK, Use GM# 12346190 Fluid	NV4500-B	1975-78	4.8L	4x2, 4 Spd, SM465 Trans, With Tail Housing Mount, Use 80W90	SM465-B
1989-91	5.7L, 6.2L, 7.4L	4x4, 4 Spd, SM465 Trans, 32 Spine Output Shaft, Use GM# 12345577 Fluid	SM465-F	P1500			
1989-91	5.7L, 6.2L, 7.4L	4x4, 4 Spd, SM465 Trans, Aluminum Top Cover, Use GM# 12345577 Fluid	SM465-I	6 CYL			
1989-91	5.7L, 6.2L, 7.4L	4x4, 5 Spd, Getrag NV3500 Trans, No Speedo, GM# 1234539 Fluid Used, 14" Tail Housing	290-A	1979-80	4.8L	4x2, 4 Spd, SM465 Trans, With Tail Housing Mount, Use 80W90	SM465-B
8 CYL				8 CYL			
1979	7.4L	4x2, 4 Spd, SM465 Trans, With Tail Housing Mount, Use 80W90	SM465-B	1979	7.4L	4x2, 4 Spd, SM465 Trans, With Tail Housing Mount, Use 80W90	SM465-B
P25				P25			
6 CYL				6 CYL			
1975-78	4.8L	4x2, 4 Spd, SM465 Trans, With Tail Housing Mount, Use 80W90	SM465-B	1975-78	4.8L	4x2, 4 Spd, SM465 Trans, With Tail Housing Mount, Use 80W90	SM465-B
8 CYL				8 CYL			
1975-78	5.7L	4x2, 4 Spd, SM465 Trans, With Tail Housing Mount, Use 80W90	SM465-B	1975-78	5.7L	4x2, 4 Spd, SM465 Trans, With Tail Housing Mount, Use 80W90	SM465-B

Pro King Manual Transmissions

YEAR	ENGINE	APPLICATION	PART NO.	YEAR	ENGINE	APPLICATION	PART NO.
GMC (cont.)				GMC (cont.)			
P2500				P3500 (cont.)			
6 CYL				6 CYL (cont.)			
1989	4.8L	4x2, 4 Spd, SM465 Trans, Aluminum Top Cover With Electric Speedo, Use GM# 12345577 Fluid	SM465-H	1991-95	4.3L	4x2, 5 Spd, NV4500 Trans, With Park Brake, REBUILDABLE CORE REQUIRED, REBUILD AND RETURN ONLY, Use GM# 12346190 Fluid	NV4500-IB
1989	4.8L	4x2, 4 Spd, SM465 Trans, Aluminum Top Cover With Mechanical Speedo, Use GM# 12345577 Fluid	SM465-G	1988-90	4.3L, 4.8L	4x2, 4 Spd, SM465 Trans, Aluminum Top Cover With Electric Speedo, Use GM# 12345577 Fluid	SM465-H
1979-87	4.8L	4x2, 4 Spd, SM465 Trans, With Tail Housing Mount, Use 80W90	SM465-B	1988-90	4.3L, 4.8L	4x2, 4 Spd, SM465 Trans, Aluminum Top Cover With Mechanical Speedo, Use GM# 12345577 Fluid	SM465-G
8 CYL				8 CYL			
1988-89	5.7L, 6.2L	4x2, 4 Spd, SM465 Trans, Aluminum Top Cover With Electric Speedo, Use GM# 12345577 Fluid	SM465-H	1979-87	4.8L	4x2, 4 Spd, SM465 Trans, With Tail Housing Mount, Use 80W90	SM465-B
1988-89	5.7L, 6.2L	4x2, 4 Spd, SM465 Trans, Aluminum Top Cover With Mechanical Speedo, Use GM# 12345577 Fluid	SM465-G	1996-99	5.7L, 6.5L, 7.4L	4x2, 5 Spd, NV4500 Trans, With Out Park Brake, CORE REQUIRED, REBUILD AND RETURN ONLY, Use GM# 12346190 Fluid	NV4500-JA
1979-87	5.7L, 6.2L	4x2, 4 Spd, SM465 Trans, With Tail Housing Mount, Use 80W90	SM465-B	1996-99	5.7L, 6.5L, 7.4L	4x2, 5 Spd, NV4500 Trans, With Park Brake, CORE REQUIRED, REBUILD AND RETURN ONLY, Use GM# 12346190 Fluid	NV4500-JB
P35				8 CYL			
6 CYL				1991-95	5.7L, 6.2L, 6.5L, 7.4L	4x2, 5 Spd, NV4500 Trans, With Out Park Brake, CORE REQUIRED, REBUILD AND RETURN ONLY, Use GM# 12346190 Fluid	NV4500-IA
1975-78	4.8L	4x2, 4 Spd, SM465 Trans, With Tail Housing Mount, Use 80W90	SM465-B	1991-95	5.7L, 6.2L, 6.5L, 7.4L	4x2, 5 Spd, NV4500 Trans, With Park Brake, REBUILDABLE CORE REQUIRED, REBUILD AND RETURN ONLY, Use GM# 12346190 Fluid	NV4500-IB
8 CYL				1988-90	5.7L, 6.2L, 7.4L	4x2, 4 Spd, SM465 Trans, Aluminum Top Cover With Electric Speedo, Use GM# 12345577 Fluid	SM465-H
1975-78	5.7L, 7.4L	4x2, 4 Spd, SM465 Trans, With Tail Housing Mount, Use 80W90	SM465-B	1988-90	5.7L, 6.2L, 7.4L	4x2, 4 Spd, SM465 Trans, Aluminum Top Cover With Mechanical Speedo, Use GM# 12345577 Fluid	SM465-G
P3500				1979-87	5.7L, 6.2L, 7.4L	4x2, 4 Spd, SM465 Trans, With Tail Housing Mount, Use 80W90	SM465-B
4 CYL				R1500			
1991	3.9L	4x2, 5 Spd, NV4500 Trans, With Out Park Brake, CORE REQUIRED, REBUILD AND RETURN ONLY, Use GM# 12346190 Fluid	NV4500-IA	6 CYL			
1991	3.9L	4x2, 5 Spd, NV4500 Trans, With Park Brake, REBUILDABLE CORE REQUIRED, REBUILD AND RETURN ONLY, Use GM# 12346190 Fluid	NV4500-IB	1987	4.3L	4 Spd, NP833 Trans (3 Spd w/OD), Iron Case Or Aluminum Case, 10 Bolt Side Cover, CORE REQUIRED, REBUILD AND RETURN ONLY, Use ATF	NP833O/D
1989-90	3.9L	4x2, 4 Spd, SM465 Trans, Aluminum Top Cover With Electric Speedo, Use GM# 12345577 Fluid	SM465-H	1987	4.3L	4x2, 4 Spd, SM465 Trans, With Tail Housing Mount, Use 80W90	SM465-B
1989-90	3.9L	4x2, 4 Spd, SM465 Trans, Aluminum Top Cover With Mechanical Speedo, Use GM# 12345577 Fluid	SM465-G	8 CYL			
6 CYL				1987	5.0L, 5.7L, 6.2L	4 Spd, NP833 Trans (3 Spd w/OD), Iron Case Or Aluminum Case, 10 Bolt Side Cover, CORE REQUIRED, REBUILD AND RETURN ONLY, Use ATF	NP833O/D
1996-99	4.3L	4x2, 5 Spd, NV4500 Trans, With Out Park Brake, CORE REQUIRED, REBUILD AND RETURN ONLY, Use GM# 12346190 Fluid	NV4500-JA	6 CYL			
1996-99	4.3L	4x2, 5 Spd, NV4500 Trans, With Park Brake, CORE REQUIRED, REBUILD AND RETURN ONLY, Use GM# 12346190 Fluid	NV4500-JB	8 CYL			
1991-95	4.3L	4x2, 5 Spd, NV4500 Trans, With Out Park Brake, CORE REQUIRED, REBUILD AND RETURN ONLY, Use GM# 12346190 Fluid	NV4500-IA	6 CYL			

Pro King Manual Transmissions

YEAR	ENGINE	APPLICATION	PART NO.	YEAR	ENGINE	APPLICATION	PART NO.
GMC (cont.)				GMC (cont.)			
SIERRA 2500 (cont.)				SONOMA (cont.)			
8 CYL (cont.)				6 CYL (cont.)			
2001-05	6.6L	4x2, 5 Spd, NV4500 Trans, CORE REQUIRED, REBUILD AND RETURN ONLY, Use GM# 12346190 Fluid	NV4500-HA	1999-03	4.3L	4x4, 5 Spd, Getrag NV3500 Trans, GM# 1234539 Fluid Used	290-L
2001-05	6.6L	4x4, 5 Spd, NV4500 Trans, CORE REQUIRED, REBUILD AND RETURN ONLY, Use GM# 12346190 Fluid	NV4500-FA	1996-98	4.3L	4x2, 5 Spd, Getrag NV3500 Trans, Press in Speedo, GM# 1234539 Fluid Used, 18.5" Tail Housing, Code GADP	290-I
1999-00	5.3L, 6.0L	4x2, 5 Spd, NV4500 Trans, W/Speedo, Cast Iron Case, 6" Tail Housing, Flat Aluminum Front Retainer, Code GAMN, Use GM# 12346190 Fluid	NV4500-G	1996-98	4.3L	4x4, 5 Spd, Getrag NV3500 Trans, No Speedo, GM# 1234539 Fluid Used, 13" Tail Housing Code, GADR GADS, Aluminum Case	290-H
1999-00	5.3L, 6.0L	4x4, 5 Spd, NV4500 Trans, No Speedo, Cast Iron Case, Flat Aluminum Front Retainer, Code GARH, Use GM# 12346190 Fluid	NV4500-E	1991-95	4.3L	4x2, 5 Spd, Getrag NV3500 Trans, Press in Electric Speedo, GM# 1234539 Fluid Used, 18.5" Tail Housing, Code GWF	290-G
SIERRA 3500				V1500			
8 CYL				6 CYL			
2001-05	6.0L, 8.1L	4x2, 5 Spd, NV4500 Trans, CORE REQUIRED, REBUILD AND RETURN ONLY, Use GM# 12346190 Fluid	NV4500-GA	1991-93	2.8L	4x2, 5 Spd, T5 Trans, Electric Speedo, ATF Used	T5-CH
2001-05	6.0L, 8.1L	4x4, 5 Spd, NV4500 Trans, With Out Vibration Damper, CORE REQUIRED, REBUILD AND RETURN ONLY, Use GM# 12346190 Fluid	NV4500-EA	1991-93	2.8L	4x4, 5 Spd, Borg Warner T5 Non WC, No Speedo, ATF Used	T5-CF
2001-05	6.6L	4x2, 5 Spd, NV4500 Trans, CORE REQUIRED, REBUILD AND RETURN ONLY, Use GM# 12346190 Fluid	NV4500-HA	8 CYL			
2001-05	6.6L	4x4, 5 Spd, NV4500 Trans, CORE REQUIRED, REBUILD AND RETURN ONLY, Use GM# 12346190 Fluid	NV4500-FA				
2001-05	6.6L	4x4, 5 Spd, NV4500 Trans, CORE REQUIRED, REBUILD AND RETURN ONLY, Use GM# 12346190 Fluid	NV4500-FA				
SONOMA				V2500			
4 CYL				6 CYL			
1999-03	2.2L	4x2, 5 Spd, NV1500 Trans, With Screw In Speedo, CORE REQUIRED, REBUILD AND RETURN ONLY, Use GM# 12377916 Fluid	NV1500-B	1987	4.8L	4 Spd, NP833 Trans (3 Spd w/OD), Iron Case Or Aluminum Case, 10 Bolt Side Cover, CORE REQUIRED, REBUILD AND RETURN ONLY, Use ATF	NP833O/D
1996-99	2.2L	4x2, 5 Spd, NV1500 Trans, With Press In Speedo, Use GM# 12377916 Fluid	NV1500-A	1987	4.8L	4x2, 4 Spd, SM465 Trans, 10 Spine Output Shaft, No Threaded Holes In Case, Use 80W90	SM465-E
1994-95	2.2L	4x2, 5 Spd, Borg Warner T5 WC, Electric Speedo, ATF Used, 26 Spline Input Shaft	T5-CJ	1987	4.8L	4x4, 4 Spd, SM465 Trans, 32 Spine Output Shaft, , Use 80W90	SM465-F
1991-95	2.2L, 2.5L	4x4, 5 Spd, Borg Warner T5 Non WC, No Speedo, ATF Used	T5-CF	8 CYL			
1991-93	2.5L	4x2, 5 Spd, T5 Trans, Electric Speedo, ATF Used	T5-CH				
1999-03	4.3L	4x2, 5 Spd, Getrag NV3500 Trans, Screw in Electric Speedo, GM# 1234539 Fluid Used, 18.5" Tail Housing, Shifter to Tail Housing, Code GBKW	290-K				

Pro King Manual Transmissions

YEAR	ENGINE	APPLICATION	PART NO.	YEAR	ENGINE	APPLICATION	PART NO.
GMC (cont.)				GMC (cont.)			
V2500 (cont.)				V3500 (cont.)			
6 CYL (cont.)				8 CYL (cont.)			
1987	4.8L	4x4, 4 Spd, SM465 Trans, 32 Spine Output Shaft, , Use 80W90	SM465-F	1987	5.7L, 6.2L, 7.4L	4x2, 4 Spd, SM465 Trans, 10 Spine Output Shaft, No Threaded Holes In Case, Use 80W90	SM465-E
8 CYL				YUKON			
1987	5.7L, 6.2L	4 Spd, NP833 Trans (3 Spd w/OD), Iron Case Or Aluminum Case, 10 Bolt Side Cover, CORE REQUIRED, REBUILD AND RETURN ONLY, Use ATF	NP833O/D	8 CYL			
1987	5.7L, 6.2L	4x2, 4 Spd, SM465 Trans, 10 Spine Output Shaft, No Threaded Holes In Case, Use 80W90	SM465-E	1996	5.7L	4x2, 5 Spd, Getrag NV3500 Trans, Press in Speedo, GM# 1234539 Fluid Used, 15" Tail Housing, Alum. Case, Code GADT	290-E
1987	5.7L, 6.2L	4x4, 4 Spd, SM465 Trans, 32 Spine Output Shaft, , Use 80W90	SM465-F	1996	5.7L	4x2, 5 Spd, NV4500 Trans, W/Speedo, Cast Iron Case, 6" Tail Housing, Flat Aluminum Front Retainer, Code GAMN, Use GM# 12346190 Fluid	NV4500-G
V3500				8 CYL			
6 CYL				1996	5.7L	4x4, 5 Spd, Getrag NV3500 Trans, CORE REQUIRED, REBUILD AND RETURN ONLY, No Speedo, GM# 1234539 Fluid Used, 14" Tail Housing, Code GADU	290-D
1988	4.8L	4x2, 4 Spd, SM465 Trans, Aluminum Top Cover With Electric Speedo, Use GM# 12345577 Fluid	SM465-H	1996	5.7L	4x4, 5 Spd, NV4500 Trans, No Speedo, Cast Iron Case, Flat Aluminum Front Retainer, Code GARH, Use GM# 12346190 Fluid	NV4500-E
1988	4.8L	4x2, 4 Spd, SM465 Trans, Aluminum Top Cover With Mechanical Speedo, Use GM# 12345577 Fluid	SM465-G	1996	6.5L	4x2, 5 Spd, NV4500 Trans, W/Speedo, Cast Iron Case With Brake, Flat Aluminum Front Retainer, Code GARF, Use GM# 12346190 Fluid	NV4500-H
1988	4.8L	4x4, 4 Spd, SM465 Trans, 32 Spine Output Shaft, Use GM# 12345577 Fluid	SM465-F	1996	6.5L	4x4, 5 Spd, NV4500 Trans, No Speedo, Cast Iron Case, Flat Aluminum Front Retainer, Code GAWN, Use GM# 12346190 Fluid	NV4500-F
1988	4.8L	4x4, 4 Spd, SM465 Trans, Aluminum Top Cover, Use GM# 12345577 Fluid	SM465-I	1994-95	6.5L	4x2, 5 Spd, NV4500 Trans, W/Speedo, Without Parking Brake, Code GAKH, Use GM# 12346190 Fluid	NV4500-D
1987-88	4.8L	4 Spd, NP833 Trans (3 Spd w/OD), Iron Case Or Aluminum Case, 10 Bolt Side Cover, CORE REQUIRED, REBUILD AND RETURN ONLY, Use ATF	NP833O/D	1994-95	6.5L	4x4, 5 Spd, NV4500 Trans, No Speedo, Cast Iron Case, Cast Iron Front Retainer, Code GAKK, Use GM# 12346190 Fluid	NV4500-B
1987	4.8L	4x2, 4 Spd, SM465 Trans, 10 Spine Output Shaft, No Threaded Holes In Case, Use 80W90	SM465-E	1993-95	5.7L	4x2, 5 Spd, NV4500 Trans, W/Speedo, 6" Tail Housing, Cast Iron Case, Cast Iron Front Retainer, Code GAKF, Use GM# 12346190 Fluid	NV4500-C
1987	4.8L	4x4, 4 Spd, SM465 Trans, 32 Spine Output Shaft, , Use 80W90	SM465-F	1993-95	5.7L	4x4, 5 Spd, NV4500 Trans, No Speedo, Cast Iron Case, Cast Iron Front Retainer, Code GAKD, Use GM# 12346190 Fluid	NV4500-A
8 CYL				1993-95	5.7L, 6.5L	4x2, 5 Spd, Getrag NV3500 Trans, GM# 1234539 Fluid Used, REBUILDABLE CORE REQUIRED, REBUILD AND RETURN ONLY, FRONT CASE MUST BE IN GOOD CONDITION	290-C
1988-91	5.7L, 6.2L, 7.4L	4x2, 4 Spd, SM465 Trans, Aluminum Top Cover With Electric Speedo, Use GM# 12345577 Fluid	SM465-H				
1988-91	5.7L, 6.2L, 7.4L	4x2, 4 Spd, SM465 Trans, Aluminum Top Cover With Mechanical Speedo, Use GM# 12345577 Fluid	SM465-G				
1988-91	5.7L, 6.2L, 7.4L	4x4, 4 Spd, SM465 Trans, 32 Spine Output Shaft, Use GM# 12345577 Fluid	SM465-F				
1988-91	5.7L, 6.2L, 7.4L	4x4, 4 Spd, SM465 Trans, Aluminum Top Cover, Use GM# 12345577 Fluid	SM465-I				
1987-88	5.7L, 6.2L, 7.4L	4 Spd, NP833 Trans (3 Spd w/OD), Iron Case Or Aluminum Case, 10 Bolt Side Cover, CORE REQUIRED, REBUILD AND RETURN ONLY, Use ATF	NP833O/D				

Pro King Manual Transmissions

YEAR	ENGINE	APPLICATION	PART NO.	YEAR	ENGINE	APPLICATION	PART NO.
GMC (cont.)				HYUNDAI (cont.)			
YUKON (cont.)				EXCEL (cont.)			
8 CYL (cont.)				4 CYL (cont.)			
1993-95	5.7L, 6.5L	4x4, 5 Spd, Getrag NV3500 Trans, No Speedo, GM# 1234539 Fluid Used, 14" Tail Housing Code GZA, REBUILDABLE CORE REQUIRED, REBUILD AND RETURN ONLY, FRONT CASE MUST BE IN GOOD CONDITION	290-AB	1986-89	1.5L	5 Spd, KM201 Trans, CORE REQUIRED, REBUILD AND RETURN ONLY, Use 75W90	KM201
1992	5.7L	4x2, 5 Spd, Getrag NV3500 Trans, GM# 1234539 Fluid Used	290-B	SCOUPE			
1992	5.7L	4x4, 5 Spd, Getrag NV3500 Trans, No Speedo, GM# 1234539 Fluid Used, 14" Tail Housing	290-A	4 CYL			
HONDA				1993-95	1.5L	5 Spd, KM301 Trans, CORE REQUIRED, REBUILD AND RETURN ONLY, Use 75W90	KM301
CIVIC				1991-92	1.5L	5 Spd, KM201 Trans, CORE REQUIRED, REBUILD AND RETURN ONLY, Use 75W90	KM201
4 CYL				SONATA			
2001-05	1.7L, 2.0L	5 Spd, SLW Trans, REBUILDABLE CORE REQUIRED, REBUILD AND RETURN ONLY, Use 10W30	SLW	4 CYL			
1996-00	1.6L	5 Spd, S40 Trans, 1 Piece Aluminum Rear Case Half, Use 10W30	S40	1999-03	2.4L	5 Spd, F5M22 Trans, CORE REQUIRED, REBUILD AND RETURN ONLY, Use 75W90	F5M22
1992-95	1.5L, 1.6L	5 Spd, S20 Trans, 1 Piece Aluminum Rear Case Half, Use 10W30	S20	ISUZU			
CIVIC DEL SOL				HOMBRE			
4 CYL				4 CYL			
1993-95	1.5L, 1.6L	5 Spd, S20 Trans, 1 Piece Aluminum Rear Case Half, Use 10W30	S20	1999-00	2.2L	4x2, 5 Spd, NV1500 Trans, With Screw In Speedo, CORE REQUIRED, REBUILD AND RETURN ONLY, Use GM# 12377916 Fluid	NV1500-B
HYUNDAI				1996-00	2.2L	4x2, 5 Spd, NV1500 Trans, With Press In Speedo, Use GM# 12377916 Fluid	NV1500-A
ACCENT				6 CYL			
4 CYL				1999	4.3L	4x2, 5 Spd, NV1500 Trans, With Screw In Speedo, CORE REQUIRED, REBUILD AND RETURN ONLY, Use GM# 12377916 Fluid	NV1500-B
1995-03	1.5L, 1.6L	5 Spd, KM302 Trans, CORE REQUIRED, REBUILD AND RETURN ONLY, Use 75W90	KM302	1997-99	4.3L	4x2, 5 Spd, NV1500 Trans, With Press In Speedo, Use GM# 12377916 Fluid	NV1500-A
ELANTRA				PICKUP			
4 CYL				4 CYL			
1992-98	1.6L, 1.8L	5 Spd, F5M22 Trans, CORE REQUIRED, REBUILD AND RETURN ONLY, Use 75W90	F5M22	1984-87	1.9L, 2.3L	4x4, 5 Spd, MSG5 Trans, 5 Tooth Speedo, Includes Transfer Case, Use 10W30	MSG-5ET-A
EXCEL				1984-87	1.9L, 2.3L	4x4, 5 Spd, MSG5 Trans, 6 Tooth Speedo, Includes Transfer Case, Use 10W30	MSG-5ET-C
4 CYL				TROOPER			
1990-94	1.5L	4 Spd, F4M21 Trans, CORE REQUIRED, REBUILD AND RETURN ONLY, Use 75W90	F4M21	4 CYL			
1990-94	1.5L	5 Spd, F5M21 Trans, CORE REQUIRED, REBUILD AND RETURN ONLY, Use 75W90	F5M21	1985-87	1.9L, 2.3L	4x4, 5 Spd, MSG5 Trans, 5 Tooth Speedo, Includes Transfer Case, Use 10W30	MSG-5ET-A
1989	1.5L	4 Spd, KM200 Trans, CORE REQUIRED, REBUILD AND RETURN ONLY, Use 75W90	KM200	1985-87	1.9L, 2.3L	4x4, 5 Spd, MSG5 Trans, 6 Tooth Speedo, Includes Transfer Case, Use 10W30	MSG-5ET-C

Pro King Manual Transmissions

YEAR	ENGINE	APPLICATION	PART NO.	YEAR	ENGINE	APPLICATION	PART NO.
JEEP				JEEP (cont.)			
CHEROKEE				CHEROKEE (cont.)			
4 CYL				6 CYL (cont.)			
2000	2.5L	4x2, 5 Spd, NV3500 Trans, CORE REQUIRED, REBUILD AND RETURN ONLY, Electric Speedo Screw in, 17.5" Tail Housing, Shifter In Rear Of Case, Use MOPAR# 4874464 Fluid	NV3500-A	1984-86	2.8L	4x4, 5 Spd, AISIN AX5, No Speedo, 75w90 Used, With 207 Transfer Case	AX5-A
2000	2.5L	4x2, 5 Spd, NV3500 Trans, CORE REQUIRED, REBUILD AND RETURN ONLY, Screw-In Speedo, 17.5" Tail Housing, Shifter In Tail Housing, Use MOPAR# 4874464 Fluid	NV3500-C	CJ			
1994-00	2.5L	4x2, 5 Spd, AISIN AX5, Push-In Speedo, 75w90 Used, External Slave Cyl	AX5-F	6 CYL			
1994-00	2.5L	4x4, 5 Spd, AISIN AX5, No Speedo, 75w90 Used, External Slave Cylinder	AX5-E	1975-79	3.8L, 4.2L	3 Spd, T90 Trans, Iron Case, Cast "T90", REBUILDABLE CORE REQUIRED, REBUILD AND RETURN ONLY, Use 80W90	T90
1987-93	2.1L, 2.5L	4x2, 5 Spd, AISIN AX5, Push-In Speedo, 75w90 Used, Internal Slave Cyl	AX5-G	COMANCHE			
1987-93	2.1L, 2.5L	4x4, 5 Spd, AISIN AX5, No Speedo, 75w90 Used, Internal Slave Cylinder	AX5-C	4 CYL			
1987-88	2.5L	4x2, 4 Spd, With Internal Slave Cylinder, Use 75W90	AX4-B	1987-92	2.1L, 2.5L	4x2, 5 Spd, AISIN AX5, Push-In Speedo, 75w90 Used, Internal Slave Cyl	AX5-G
1985-86	2.1L	4x4, 4 Spd, With External Slave Cylinder, Use 75W90	AX4-C	1987-92	2.5L	4x4, 5 Spd, AISIN AX5, No Speedo, 75w90 Used, Internal Slave Cylinder	AX5-C
1984-86	2.1L, 2.5L	4x2, 4 Spd, With External Slave Cylinder, Use 75W90	AX4-A	1986-88	2.5L	4x2, 4 Spd, With Internal Slave Cylinder, Use 75W90	AX4-B
1984-86	2.1L, 2.5L	4x2, 5 Spd, AISIN AX5, Push-In Speedo, 75w90 Used, External Slave Cyl	AX5-F	1986	2.1L	4x4, 4 Spd, With External Slave Cylinder, Use 75W90	AX4-C
1984-86	2.1L, 2.5L	4x4, 5 Spd, AISIN AX5, No Speedo, 75w90 Used, With 207 Transfer Case	AX5-A	1986	2.1L, 2.5L	4x2, 4 Spd, With External Slave Cylinder, Use 75W90	AX4-A
1984-86	2.5L	4x4, 4 Spd, With Internal Slave Cylinder, Use 75W90	AX4-E	1986	2.1L, 2.5L	4x2, 5 Spd, AISIN AX5, Push-In Speedo, 75w90 Used, External Slave Cyl	AX5-F
6 CYL				1986	2.1L, 2.5L	4x4, 5 Spd, AISIN AX5, No Speedo, 75w90 Used, With 207 Transfer Case	AX5-A
2001	4.0L	4x4, 5 Spd, NV3550 Trans, Use MOPAR# 4874464 Fluid	NV3550-C	6 CYL			
2000	4.0L	4x2, 5 Spd, NV3550 Trans, Use MOPAR# 4874464 Fluid	NV3550-A	1992	4.0L	4x4, 5 Spd, AX15 Trans, No Speedo, 75w90 Used, Internal Slave Cylinder .750" Pilot	AX15-F
1994-99	4.0L	4x2, 5 Spd, AX15 Trans, Use Synthetic 75W90	AX15-IH	1989-91	4.0L	4x2, 5 Spd, AX15 Trans, Use Synthetic 75W90	AX15-IF
1994-99	4.0L	4x4, 5 Spd, AX15 Trans, No Speedo, 75w90 Used, External Slave Cylinder .750" Pilot	AX15-H	1989-91	4.0L	4x4, 5 Spd, AX15 Trans, No Speedo, 75w90 Used, Internal Slave Cylinder .590" Pilot	AX15-D
1992-93	4.0L	4x2, 5 Spd, AX15 Trans, Use Synthetic 75W90	AX15-IG	1987-90	4.0L	4x2, 5 Spd, Peugeot Trans, Use 75W90	BA10-C
1992-93	4.0L	4x4, 5 Spd, AX15 Trans, No Speedo, 75w90 Used, Internal Slave Cylinder .750" Pilot	AX15-F	1987-90	4.0L	4x4, 5 Spd, Peugeot Trans, Use 75W90	BA10-B
1989-91	4.0L	4x4, 5 Spd, AX15 Trans, No Speedo, 75w90 Used, Internal Slave Cylinder .590" Pilot	AX15-D	1986	2.8L	4x2, 4 Spd, With External Slave Cylinder, Use 75W90	AX4-A
1987-90	4.0L	4x2, 5 Spd, Peugeot Trans, Use 75W90	BA10-C	1986	2.8L	4x2, 5 Spd, AISIN AX5, Push-In Speedo, 75w90 Used, External Slave Cyl	AX5-F
1987-90	4.0L	4x4, 5 Spd, Peugeot Trans, Use 75W90	BA10-B	1986	2.8L	4x4, 4 Spd, With External Slave Cylinder, Use 75W90	AX4-C
1984-86	2.8L	4x2, 4 Spd, With External Slave Cylinder, Use 75W90	AX4-A	1986	2.8L	4x4, 5 Spd, AISIN AX5, No Speedo, 75w90 Used, With 207 Transfer Case	AX5-A
1984-86	2.8L	4x2, 5 Spd, AISIN AX5, Push-In Speedo, 75w90 Used, External Slave Cyl	AX5-F	GRAND CHEROKEE			
6 CYL				6 CYL			
1994	4.0L	4x4, 5 Spd, AX15 Trans, No Speedo, 75w90 Used, External Slave Cylinder .750" Pilot	AX15-H	1994	4.0L	4x4, 5 Spd, AX15 Trans, No Speedo, 75w90 Used, External Slave Cylinder .750" Pilot	AX15-H
1993	4.0L	4x4, 5 Spd, AX15 Trans, No Speedo, 75w90 Used, Internal Slave Cylinder .750" Pilot	AX15-F	6 CYL			

Pro King Manual Transmissions

YEAR	ENGINE	APPLICATION	PART NO.	YEAR	ENGINE	APPLICATION	PART NO.
JEEP (cont.)				JEEP (cont.)			
LIBERTY				WRANGLER (cont.)			
6 CYL				6 CYL (cont.)			
2002-04	3.7L	4x4, 5 Spd, NV3550 Trans, Getrag Design With Removable Bell Housing, Use MOPAR# 4874464 Fluid	NV3550-B	1992-93	4.0L	4x4, 5 Spd, AX15 Trans, No Speedo, 75w90 Used, Internal Slave Cylinder .750" Pilot	AX15-E
WAGONEER				1989-91	4.0L, 4.2L	4x4, 5 Spd, AX15 Trans, No Speedo, 75w90 Used, Internal Slave Cylinder .590" Pilot	AX15-C
4 CYL				1987-90	4.2L	4x4, 5 Spd, Peugeot Trans, Use 75W90	BA10-A
1987	2.5L	4x2, 5 Spd, AISIN AX5, Push-In Speedo, 75w90 Used, Internal Slave Cyl	AX5-G	KIA			
1987	2.5L	4x4, 5 Spd, AISIN AX5, No Speedo, 75w90 Used, Internal Slave Cylinder	AX5-C	SPORTAGE			
1985	2.1L	4x4, 5 Spd, AISIN AX5, No Speedo, 75w90 Used, External Slave Cylinder	AX5-E	4 CYL			
1984-86	2.1L, 2.5L	4x2, 4 Spd, With External Slave Cylinder, Use 75W90	AX4-A	1995-98	2.0L	4x2, 5 Spd, SPORT Trans, Use SYNTHETIC 75W90	SPORT-A
1984-86	2.1L, 2.5L	4x4, 4 Spd, With External Slave Cylinder, Use 75W90	AX4-C	1995-98	2.0L	4x4, 5 Spd, SPORT Trans, Use SYNTHETIC 75W90	SPORT-B
1984-86	2.1L, 2.5L	4x4, 5 Spd, AISIN AX5, No Speedo, 75w90 Used, With 207 Transfer Case	AX5-A	LEXUS			
1984-86	2.5L	4x2, 5 Spd, AISIN AX5, Push-In Speedo, 75w90 Used, External Slave Cyl	AX5-F	ES250			
6 CYL				6 CYL			
1987	4.0L	4x2, 5 Spd, Peugeot Trans, Use 75W90	BA10-C	1990-91	2.5L	5 Spd, E52 Trans, CORE REQUIRED, REBUILD AND RETURN ONLY, Use 75W90	E52
1987	4.0L	4x4, 5 Spd, Peugeot Trans, Use 75W90	BA10-B	ES300			
1984-86	2.8L	4x2, 4 Spd, With External Slave Cylinder, Use 75W90	AX4-A	6 CYL			
1984-86	2.8L	4x2, 5 Spd, AISIN AX5, Push-In Speedo, 75w90 Used, External Slave Cyl	AX5-F	1992-93	3.0L	5 Spd, E52 Trans, CORE REQUIRED, REBUILD AND RETURN ONLY, Use 75W90	E52
1984-86	2.8L	4x4, 4 Spd, With External Slave Cylinder, Use 75W90	AX4-C	MAZDA			
1984-86	2.8L	4x4, 5 Spd, AISIN AX5, No Speedo, 75w90 Used, With 207 Transfer Case	AX5-A	323			
WRANGLER				4 CYL			
4 CYL				1991-94	1.6L	5 Spd, M5TX Trans, CORE REQUIRED, REBUILD AND RETURN ONLY, Use ATF	M5TX
2000-02	2.5L	4x4, 5 Spd, AISIN AX5, No Speedo, 75w90 Used, External Slave Cylinder	AX5-D	626			
1997-98	2.5L	4x4, 5 Spd, AISIN AX5, No Speedo, 75w90 Used, External Slave Cylinder	AX5-D	4 CYL			
1994-95	2.5L	4x4, 5 Spd, AISIN AX5, No Speedo, 75w90 Used, External Slave Cylinder	AX5-D	1993-02	2.0L	5 Spd, M5TX Trans, CORE REQUIRED, REBUILD AND RETURN ONLY, Use ATF	M5TXA
1987-93	2.5L	4x4, 5 Spd, AISIN AX5, No Speedo, 75w90 Used, Internal Slave Cylinder	AX5-B	B SERIES PICKUP			
6 CYL				4 CYL			
2000-04	4.0L	4x4, 5 Spd, NV3550 Trans, Getrag Design With Removable Bell Housing, Use MOPAR# 4874464 Fluid	NV3550-B	2001-03	2.3L	4x2, 5 Spd, M5R1 Trans, 1 Switch In Top Cover, White 7 Tooth Speedo, Use ATF	M5R1-QA
1997-99	4.0L	4x4, 5 Spd, AX15 Trans, No Speedo, 75w90 Used, External Slave Cylinder .750" Pilot	AX15-G	2001-03	2.3L	4x2, 5 Spd, M5R1 Trans, CORE REQUIRED, REBUILD AND RETURN ONLY, Use ATF	M5R1-T
1994-95	4.0L	4x4, 5 Spd, AX15 Trans, No Speedo, 75w90 Used, External Slave Cylinder .750" Pilot	AX15-G	2001-03	2.3L	4x4, 5 Spd, M5R1 Trans, 1 Switch In top Cover, Use ATF	M5R1-LA
				1995-97	2.3L	4x2, 5 Spd, M5R1 Trans, 1 Switch In top Cover, No Speedo, Use ATF	M5R1-PA

Pro King Manual Transmissions

YEAR	ENGINE	APPLICATION	PART NO.	YEAR	ENGINE	APPLICATION	PART NO.
MAZDA (cont.)				MAZDA (cont.)			
B SERIES PICKUP (cont.)				B SERIES PICKUP (cont.)			
4 CYL (cont.)				6 CYL (cont.)			
1995-97	2.3L	4x2, 5 Spd, M5R1 Trans, 1 Switch In Top Cover, White 7 Tooth Speedo, Use ATF	M5R1-QA	1998	3.0L	4x2, 5 Spd, M5R1 Trans, CORE REQUIRED, REBUILD AND RETURN ONLY, 1 Switch in top Cover, Trigger Wheel Speedo, Use ATF	M5R1-S
1995-97	2.3L	4x4, 5 Spd, M5R1 Trans, 1 Switch In top Cover, Use ATF	M5R1-LA	1998	3.0L	4x2, 5 Spd, M5R1 Trans, Speedo- Purple 6 teeth, ATF Used, 3 Hole Starter Left Side	M5R1-I
1994	2.3L	4x2, 5 Spd, M5R1 Trans, No Speedo, ATF Used, 3 Hole Starter Right Side, 1 Switch In Top Cover	M5R1-P	1998	3.0L	4x2, 5 Spd, M5R1 Trans, Speedo- White 7 teeth, ATF Used, 3 Hole Starter Left Side	M5R1-K
1994	2.3L	4x2, 5 Spd, M5R1 Trans, Speedo- Purple 6 teeth, ATF Used, 3 Hole Starter Right Side, 2 Switches Top Cover	M5R1-O	1998	3.0L	4x4, 5 Spd, M5R1 Trans, Use ATF	M5R1-HA
1994	2.3L	4x2, 5 Spd, M5R1 Trans, Speedo- White 7 teeth, ATF Used, 3 Hole Starter Right Side, 1 Switch In Top Cover	M5R1-Q	1995-96	3.0L	4x2, 5 Spd, M5R1 Trans, No Speedo, Use ATF	M5R1-JA
1994	2.3L	4x2, 5 Spd, M5R1 Trans, Speedo- White 7 teeth, ATF Used, 3 Hole Starter Right Side, 2 Switches In Top Cover	M5R1-R	1995-96	3.0L	4x4, 5 Spd, M5R1 Trans, Use ATF	M5R1-HA
1994	2.3L	4x4, 5 Spd, M5R1 Trans, No Speedo, ATF Used, 1 Switch Top Cover	M5R1-L	1995-03	4.0L	4x2, 5 Spd, M5R1 Trans, No Speedo, Use ATF	M5R1-DA
1994	2.3L	4x4, 5 Spd, M5R1 Trans, No Speedo, ATF Used, 2 Switches Top Cover	M5R1-M	1995-03	4.0L	4x2, 5 Spd, M5R1 Trans, With 6 Tooth Purple Speedo Gear, Use ATF	M5R1-CA
1987-93	2.6L	4x2, 5 Spd, Aluminum Case With Aluminum Bottom Pan, CORE REQUIRED, REBUILD AND RETURN ONLY, Use 75W90	B2600-A	1995-03	4.0L	4x2, 5 Spd, M5R1, Speedo- White 7 teeth, ATF Used, One Switch on Top Cover	M5R1-EA
1987-93	2.6L	4x4, 5 Spd, Aluminum Case With Aluminum Bottom Pan, CORE REQUIRED, REBUILD AND RETURN ONLY, Use 75W90	B2600-B	1995-00	4.0L	4x4, 5 Spd, M5R1 Trans, Use ATF	M5R1-BA
1979-84	2.0L	4x2, 5 Spd, Aluminum Case, No Ribbing On Bell Housing, Use 75W90	B2000	1994-96	3.0L	4x2, 5 Spd, M5R1 Trans, Speedo- Purple 6 teeth, ATF Used, 3 Hole Starter Left Side	M5R1-I
6 CYL				1994-96	3.0L	4x2, 5 Spd, M5R1 Trans, Speedo- White 7 teeth, ATF Used, 3 Hole Starter Left Side	M5R1-K
2006	3.0L	4x2, 5 Spd, M5R1 Trans, CORE REQUIRED, REBUILD AND RETURN ONLY, 1 Switch in top Cover, Trigger Wheel Speedo, Use ATF	M5R1-S	1994	3.0L	4x2, 5 Spd, M5R1 Trans, No Speedo, ATF Used, 3 Hole Starter Left Side	M5R1-J
2006	4.0L	4x4, 5 Spd, M5R1 Trans, With Speedo Sensor In Tail Housing, Use ATF	M5R1-BB	1994	3.0L	4x4, 5 Spd, M5R1 Trans, No Speedo, ATF Used, 3 Hole Starter Left Side	M5R1-H
2001-03	3.0L	4x2, 5 Spd, M5R1 Trans, CORE REQUIRED, REBUILD AND RETURN ONLY, 1 Switch in top Cover, Trigger Wheel Speedo, Use ATF	M5R1-S	1994	4.0L	4x2, 5 Spd, M5R1 Trans, No Speedo, ATF Used, 2 Hole Starter Left Side	M5R1-D
2001-03	3.0L	4x2, 5 Spd, M5R1 Trans, Speedo- Purple 6 teeth, ATF Used, 3 Hole Starter Left Side	M5R1-I	1994	4.0L	4x2, 5 Spd, M5R1 Trans, Speedo- Purple 6 teeth, ATF Used, 2 Hole Starter Left Side	M5R1-C
2001-03	3.0L	4x2, 5 Spd, M5R1 Trans, Speedo- White 7 teeth, ATF Used, 3 Hole Starter Left Side	M5R1-K	1994	4.0L	4x2, 5 Spd, M5R1 Trans, Speedo- White 7 teeth, ATF Used, 2 Hole Starter Left Side	M5R1-E
2001-03	3.0L	4x4, 5 Spd, M5R1 Trans, Use ATF	M5R1-HA	1994	4.0L	4x4, 5 Spd, M5R1 Trans, No Speedo, ATF Used, 2 Hole Starter Left Side, Use ATF	M5R1-B
2001-03	4.0L	4x4, 5 Spd, M5R1 Trans, With Speedo Sensor In Tail Housing, Use ATF	M5R1-BB	MIATA			
				4 CYL			
				1990-93	1.6L	5 Spd, MX5 Trans, CORE REQUIRED, REBUILD AND RETURN ONLY	MX5
				MX-3			
				4 CYL			
				1992-95	1.6L	5 Spd, M5TX Trans, CORE REQUIRED, REBUILD AND RETURN ONLY, Use ATF	M5TX

Pro King Manual Transmissions

YEAR	ENGINE	APPLICATION	PART NO.	YEAR	ENGINE	APPLICATION	PART NO.
MAZDA (cont.)				MERCURY (cont.)			
MX-6				COUGAR (cont.)			
4 CYL				6 CYL (cont.)			
1993-97	2.0L	5 Spd, M5TX Trans, CORE REQUIRED, REBUILD AND RETURN ONLY, Use ATF	M5TXA	1990	3.8L	4x2, 5 Spd, M5R2 Trans, Speedo- Green 8 Teeth, ATF Used	M5R2-B
NAVAJO				8 CYL			
6 CYL				1997	4.6L	4x2, 5 Spd, M5R2 Trans, Speedo- Green 8 Teeth, ATF Used, CORE REQUIRED, REBUILD AND RETURN ONLY	M5R2-H
1991-94	4.0L	4x2, 5 Spd, M5R1 Trans, No Speedo, ATF Used, 2 Hole Starter Left Side	M5R1-D	1996	4.6L	4x2, 5 Spd, M5R2 Trans, No Speedo, ATF Used	M5R2-C
1991-94	4.0L	4x2, 5 Spd, M5R1 Trans, Speedo- Purple 6 teeth, ATF Used, 2 Hole Starter Left Side	M5R1-C	1996	4.6L	4x2, 5 Spd, M5R2 Trans, Speedo- Green 8 Teeth, ATF Used	M5R2-B
1991-94	4.0L	4x2, 5 Spd, M5R1 Trans, Speedo- White 7 teeth, ATF Used, 2 Hole Starter Left Side	M5R1-E	1996	4.6L	4x2, 5 Spd, M5R2 Trans, Speedo- White 8 Teeth, ATF Used	M5R2-D
1991-94	4.0L	4x4, 5 Spd, M5R1 Trans, No Speedo, ATF Used, 2 Hole Starter Left Side, Use ATF	M5R1-B	MYSTIQUE			
PROTEGE				4 CYL			
1999-01	1.6L	5 Spd, M5TX Trans, CORE REQUIRED, REBUILD AND RETURN ONLY, Use ATF	M5TX	1995-00	2.0L	5 Spd, MTX75 Trans, 6 Bolt Shift Tower, CORE REQUIRED, REBUILD AND RETURN ONLY, Use ATF	MTX75-A
1991-03	1.8L, 2.0L	5 Spd, M5TX Trans, CORE REQUIRED, REBUILD AND RETURN ONLY, Use ATF	M5TXA	6 CYL			
RX-7				1995-00	2.5L	5 Spd, MTX75 Trans, 6 Bolt Shift Tower, CORE REQUIRED, REBUILD AND RETURN ONLY, Use ATF	MTX75-B
ROTARY 2				MITSUBISHI			
1986-91	1.3L	5 Spd, RX7 Trans, CORE REQUIRED, REBUILD AND RETURN ONLY, Use 75W90	RX7B	3000GT			
1981-85	1.1L, 1.3L	5 Spd, RX7 Trans, Use 75W90	RX7A	6 CYL			
1979-80	1.1L	5 Spd, RX7 Trans	RX7	1991-92	3.0L	4x4, 5 Spd, W5MG1 Trans, 12 Bolt Aluminum Cover Over 5th Gears, REBUILDABLE CORE REQUIRED, REBUILD AND RETURN ONLY, Use 75W90	W5MG1
MERCURY				ECLIPSE			
COUGAR				4 CYL			
4 CYL				1995-98	2.0L	5 Spd, All Aluminum Case, Cable Operated Clutch, Use MOPAR# 4874465 Fluid	A578-A
2000-02	2.0L	5 Spd, MTX75 Trans, 6 Bolt Shift Tower, CORE REQUIRED, REBUILD AND RETURN ONLY, Use ATF	MTX75-A	1995-98	2.0L	5 Spd, All Aluminum Case, Hydraulic Operated Clutch, Use MOPAR# 4874465 Fluid	A578-B
6 CYL				1990-94	1.8L	5 Spd, F5M22 Trans, CORE REQUIRED, REBUILD AND RETURN ONLY, Use 75W90	F5M22
2000-02	2.5L	5 Spd, MTX75 Trans, 6 Bolt Shift Tower, CORE REQUIRED, REBUILD AND RETURN ONLY, Use ATF	MTX75-B	1990	2.0L	5 Spd, KM206 Trans, CORE REQUIRED, REBUILD AND RETURN ONLY, Use 75W90	KM206
1997	3.8L	4x2, 5 Spd, M5R2 Trans, Speedo- Green 8 teeth, ATF Used, CORE REQUIRED, REBUILD AND RETURN ONLY	M5R2-G	EXPO LRV			
1996	3.8L	4x2, 5 Spd, M5R2 Trans, No Speedo, ATF Used	M5R2-C	4 CYL			
1996	3.8L	4x2, 5 Spd, M5R2 Trans, Speedo- Green 8 Teeth, ATF Used	M5R2-B	1992-94	1.8L, 2.4L	5 Spd, F5M22 Trans, CORE REQUIRED, REBUILD AND RETURN ONLY, Use 75W90	F5M22
1996	3.8L	4x2, 5 Spd, M5R2 Trans, Speedo- White 8 Teeth, ATF Used	M5R2-D	70			
1990	3.8L	4x2, 5 Spd, M5R2 Trans, No Speedo, ATF Used	M5R2-C				

Pro King Manual Transmissions

YEAR	ENGINE	APPLICATION	PART NO.	YEAR	ENGINE	APPLICATION	PART NO.
mitsubishi (cont.)				NISSAN (cont.)			
GALANT				300ZX			
4 CYL				6 CYL			
1989	2.0L	5 Spd, KM206 Trans, CORE REQUIRED, REBUILD AND RETURN ONLY, Use 75W90	KM206	1990-96	3.0L	5 Spd, RS5R30A Trans, CORE REQUIRED, REBUILD AND RETURN ONLY, Non Turbo, Aluminum 1 Piece Case And Bell Housing, Use 20W50	FS5R30-E
MIGHTY MAX				300ZX			
4 CYL				6 CYL			
1986	2.0L	4x4, 5 Spd, KM145 Trans, Cable Operated Clutch	KM145-1	1990-96	3.0L	5 Spd, RS5R30A Trans, CORE REQUIRED, REBUILD AND RETURN ONLY, Twin Turbo, Aluminum 1 Piece Case And Bell Housing, Use 20W50	FS5R30-F
MIRAGE				300ZX			
4 CYL				6 CYL			
1991-96	1.6L, 1.8L	5 Spd, F5M22 Trans, CORE REQUIRED, REBUILD AND RETURN ONLY, Use 75W90	F5M22	1986-89	3.0L	5 Spd, RS5R30A Trans, CORE REQUIRED, REBUILD AND RETURN ONLY, Turbo, Aluminum 1 Piece Case And Bell Housing, Use 20W50	FS5R30-C
1990-96	1.5L	5 Spd, F5M21 Trans, CORE REQUIRED, REBUILD AND RETURN ONLY, Use 75W90	F5M21	1984-87	3.0L	5 Spd, FS5W71, CORE REQUIRED, REBUILD AND RETURN ONLY, W/Speedo, 20W50 Used	FS5W71-N
1990-92	1.5L	4 Spd, F4M21 Trans, CORE REQUIRED, REBUILD AND RETURN ONLY, Use 75W90	F4M21	350Z			
1989	1.6L	5 Spd, KM210 Trans, 7 Bolt Cover Over 5th Gears, CORE REQUIRED, REBUILD AND RETURN ONLY, Use 75W90	KM210	6 CYL			
1987-89	1.5L	5 Spd, KM201 Trans, CORE REQUIRED, REBUILD AND RETURN ONLY, Use 75W90	KM201	2003-06	3.5L	6 Spd, FS6R31A Trans, CORE REQUIRED, REBUILD AND RETURN ONLY	FS6R31A
1987-88	1.6L	5 Spd, KM206 Trans, CORE REQUIRED, REBUILD AND RETURN ONLY, Use 75W90	KM206	ALTIMA			
1987	1.5L	4 Spd, KM200 Trans, CORE REQUIRED, REBUILD AND RETURN ONLY, Use 75W90	KM200	4 CYL			
PRECIS				4 CYL			
1987-94	1.5L	4 Spd, KM200 Trans, CORE REQUIRED, REBUILD AND RETURN ONLY, Use 75W90	KM200	1993-02	2.4L, 2.5L	5 Spd, RS5F50A Trans, 2 Piece Aluminum Case With 2" Plug AT Back Of Case, REBUILDABLE CORE REQUIRED, REBUILD AND RETURN ONLY	RS5F50C
NISSAN				6 CYL			
200SX				6 CYL			
4 CYL				6 CYL			
1984-87	1.8L, 2.0L	5 Spd, FS5W71 Trans, CORE REQUIRED, REBUILD AND RETURN ONLY, Use 20W50	FS5W71-M	2002	3.5L	5 Spd, RS5F50A Trans, 2 Piece Aluminum Case With 2" Plug AT Back Of Case, REBUILDABLE CORE REQUIRED, REBUILD AND RETURN ONLY	RS5F50C
6 CYL				D21			
1987	3.0L	5 Spd, FS5W71 Trans, CORE REQUIRED, REBUILD AND RETURN ONLY, Use 20W50	FS5W71-M	4 CYL			
NISSAN				4 CYL			
200SX				4 CYL			
4 CYL				4 CYL			
1987-94	2.4L	4x2, 5 Spd, FS5W71 Trans, 6 Bolt Shifter Housing, Use 20W50	FS5W71-E	6 CYL			
1987-94	2.4L	4x4, 5 Spd, FS5W71 Trans, Direct Mount To Transfer Case, Use 20W50	FS5W71-G	6 CYL			
6 CYL				6 CYL			
1992-93	3.0L	4x2, 5 Spd, FS5R30 Trans, Use 20W50	FS5R30-B	D21 SE			
1992-93	3.0L	4x4, 5 Spd, FS5R30 Trans, Direct Mount To Transfer Case, Use 20W50	FS5R30-A	6 CYL			
D21 SE				6 CYL			
6 CYL				6 CYL			
1992-94	3.0L	4x2, 5 Spd, FS5R30 Trans, Use 20W50	FS5R30-B	D21 SE			
1992-94	3.0L	4x4, 5 Spd, FS5R30 Trans, Direct Mount To Transfer Case, Use 20W50	FS5R30-A	6 CYL			

Pro King Manual Transmissions

YEAR	ENGINE	APPLICATION	PART NO.	YEAR	ENGINE	APPLICATION	PART NO.
NISSAN (cont.)				NISSAN (cont.)			
D21 XE				PICKUP (cont.)			
4 CYL				4 CYL (cont.)			
1994	2.4L	4x2, 5 Spd, FS5W71 Trans, 6 Bolt Shifter Housing, Use 20W50	FS5W71-E	1995	2.4L	4x4, 5 Spd, FS5W71 Trans, Direct Mount To Transfer Case, Use 20W50	FS5W71-G
1994	2.4L	4x4, 5 Spd, FS5W71 Trans, Direct Mount To Transfer Case, Use 20W50	FS5W71-G	6 CYL			
FRONTIER				SENTRA			
4 CYL				4 CYL			
1998-03	2.4L	4x2, 5 Spd, FS5W71 Trans, Crank Position Sensor In Bell Housing, CORE REQUIRED, REBUILD AND RETURN ONLY, Use 20W50	FS5W71-HA	1995	3.0L	4x2, 5 Spd, FS5R30 Trans, Use 20W50	FS5R30-B
1998-03	2.4L	4x4, 5 Spd, FS5W71 Trans, Crank Position Sensor In Bell Housing, CORE REQUIRED, REBUILD AND RETURN ONLY, Use 20W50	FS5W71-I	1995	3.0L	4x4, 5 Spd, FS5R30 Trans, Direct Mount To Transfer Case, Use 20W50	FS5R30-A
6 CYL				STANZA			
1999-03	3.3L	4x4, 5 Spd, FS5R30 Trans, With Bell Housing Sensor, Use 20W50	FS5R30-D	4 CYL			
MAXIMA				4 CYL			
6 CYL				4 CYL			
1985-01	3.0L	5 Spd, RS5F50A Trans, 2 Piece Aluminum Case, REBUILDABLE CORE REQUIRED, REBUILD AND RETURN ONLY	RS5F50A	1987-90	1.6L, 1.7L	5 Spd, RS5F31A Trans, 2 Piece Aluminum Case	RS5F31A
PATHFINDER				VAN			
4 CYL				4 CYL			
1987	2.4L	4x2, 5 Spd, FS5W71 Trans, 6 Bolt Shifter Housing, Use 20W50	FS5W71-E	1987-88	2.4L	4x2, 5 Spd, FS5W71 Trans, 6 Bolt Shifter Housing, Use 20W50	FS5W71-E
1987	2.4L	4x4, 5 Spd, FS5W71 Trans, Direct Mount To Transfer Case, Use 20W50	FS5W71-G	1987-88	2.4L	4x4, 5 Spd, FS5W71 Trans, Direct Mount To Transfer Case, Use 20W50	FS5W71-G
6 CYL				XTERRA			
1996-02	3.3L, 3.5L	4x4, 5 Spd, FS5R30 Trans, With Bell Housing Sensor, Use 20W50	FS5R30-D	4 CYL			
1987-95	3.0L	4x2, 5 Spd, FS5R30 Trans, Use 20W50	FS5R30-B	2000-03	2.4L	4x2, 5 Spd, FS5W71 Trans, Crank Position Sensor In Bell Housing, CORE REQUIRED, REBUILD AND RETURN ONLY, Use 20W50	FS5W71-HA
1987-95	3.0L	4x4, 5 Spd, FS5R30 Trans, Direct Mount To Transfer Case, Use 20W50	FS5R30-A	2000-03	2.4L	4x4, 5 Spd, FS5W71 Trans, Crank Position Sensor In Bell Housing, CORE REQUIRED, REBUILD AND RETURN ONLY, Use 20W50	FS5W71-I
PICKUP				OLDSMOBILE			
4 CYL				ACHIEVA			
4 CYL				4 CYL			
1996-97	2.4L	4x2, 5 Spd, FS5W71 Trans, Crank Position Sensor In Bell Housing, CORE REQUIRED, REBUILD AND RETURN ONLY, Use 20W50	FS5W71-H	1992-97	2.3L, 2.4L	5 Spd, MR8 Isuzu Style Trans, Aluminum Rear Cover Over 5th Gears, CORE REQUIRED, REBUILD AND RETURN ONLY, Use GM# 12345349 Fluid	MR8
1996-97	2.4L	4x4, 5 Spd, FS5W71 Trans, Crank Position Sensor In Bell Housing, CORE REQUIRED, REBUILD AND RETURN ONLY, Use 20W50	FS5W71-I	1992-94	2.3L	5 Spd, MR10 Muncie Style Trans, Flat Metal Cover Over 5th Gears, CORE REQUIRED, REBUILD AND RETURN ONLY, Use GM# 12345349 Fluid	MR10
1995	2.4L	4x2, 5 Spd, FS5W71 Trans, 6 Bolt Shifter Housing, Use 20W50	FS5W71-E				

Pro King Manual Transmissions

YEAR	ENGINE	APPLICATION	PART NO.	YEAR	ENGINE	APPLICATION	PART NO.
OLDSMOBILE (cont.)				OLDSMOBILE (cont.)			
ACHIEVA (cont.)				FIRENZA (cont.)			
6 CYL				4 CYL (cont.)			
1992-97	3.1L, 3.3L	5 Spd, MR8 Isuzu Style Trans, Aluminum Rear Cover Over 5th Gears, CORE REQUIRED, REBUILD AND RETURN ONLY, Use GM# 12345349 Fluid	MR8	1986-88	1.8L, 2.0L	5 Spd, MR8 Isuzu Style Trans, Aluminum Rear Cover Over 5th Gears, CORE REQUIRED, REBUILD AND RETURN ONLY, Use GM# 12345349 Fluid	MR8
1992-94	3.1L, 3.3L	5 Spd, MR10 Muncie Style Trans, Flat Metal Cover Over 5th Gears, CORE REQUIRED, REBUILD AND RETURN ONLY, Use GM# 12345349 Fluid	MR10	1983-84	1.8L, 2.0L	5 Spd, MR8 Isuzu Style Trans, Aluminum Rear Cover Over 5th Gears, CORE REQUIRED, REBUILD AND RETURN ONLY, Use GM# 12345349 Fluid	MR8
CALAIS				6 CYL			
4 CYL				1987	2.8L	5 Spd, MR10 Muncie Style Trans, Flat Metal Cover Over 5th Gears, CORE REQUIRED, REBUILD AND RETURN ONLY, Use GM# 12345349 Fluid	MR10
1986-87	2.3L, 2.5L	5 Spd, MR8 Isuzu Style Trans, Aluminum Rear Cover Over 5th Gears, CORE REQUIRED, REBUILD AND RETURN ONLY, Use GM# 12345349 Fluid	MR8	1986-87	2.8L	5 Spd, MR8 Isuzu Style Trans, Aluminum Rear Cover Over 5th Gears, CORE REQUIRED, REBUILD AND RETURN ONLY, Use GM# 12345349 Fluid	MR8
6 CYL				PLYMOUTH			
1986-87	3.0L	5 Spd, MR8 Isuzu Style Trans, Aluminum Rear Cover Over 5th Gears, CORE REQUIRED, REBUILD AND RETURN ONLY, Use GM# 12345349 Fluid	MR8	BREEZE			
CUTLASS				4 CYL			
6 CYL				1996-98	2.0L, 2.4L	5 Spd, All Aluminum Case, Cable Operated Clutch, Use MOPAR# 4874465 Fluid	A578-A
1997	3.1L	5 Spd, MR8 Isuzu Style Trans, Aluminum Rear Cover Over 5th Gears, CORE REQUIRED, REBUILD AND RETURN ONLY, Use GM# 12345349 Fluid	MR8	1996-98	2.0L, 2.4L	5 Spd, All Aluminum Case, Hydraulic Operated Clutch, Use MOPAR# 4874465 Fluid	A578-B
CUTLASS SUPREME				COLT			
4 CYL				4 CYL			
1990	2.3L	5 Spd, MR10 Muncie Style Trans, Flat Metal Cover Over 5th Gears, CORE REQUIRED, REBUILD AND RETURN ONLY, Use GM# 12345349 Fluid	MR10	1993-94	1.8L, 2.4L	5 Spd, F5M22 Trans, CORE REQUIRED, REBUILD AND RETURN ONLY, Use 75W90	F5M22
6 CYL				1992	1.5L	4 Spd, F4M21 Trans, CORE REQUIRED, REBUILD AND RETURN ONLY, Use 75W90	F4M21
1988-90	2.8L, 3.1L	5 Spd, MR10 Muncie Style Trans, Flat Metal Cover Over 5th Gears, CORE REQUIRED, REBUILD AND RETURN ONLY, Use GM# 12345349 Fluid	MR10	1990-94	1.5L	5 Spd, F5M21 Trans, CORE REQUIRED, REBUILD AND RETURN ONLY, Use 75W90	F5M21
FIRENZA				1990	1.5L	4 Spd, F4M21 Trans, CORE REQUIRED, REBUILD AND RETURN ONLY, Use 75W90	F4M21
4 CYL				1990	1.6L, 1.8L	5 Spd, F5M22 Trans, CORE REQUIRED, REBUILD AND RETURN ONLY, Use 75W90	F5M22
1987	2.0L	5 Spd, MR10 Muncie Style Trans, Flat Metal Cover Over 5th Gears, CORE REQUIRED, REBUILD AND RETURN ONLY, Use GM# 12345349 Fluid	MR10	1989	1.6L	5 Spd, KM210 Trans, 7 Bolt Cover Over 5th Gears, CORE REQUIRED, REBUILD AND RETURN ONLY, Use 75W90	KM210

Pro King Manual Transmissions

YEAR	ENGINE	APPLICATION	PART NO.	YEAR	ENGINE	APPLICATION	PART NO.
PLYMOUTH (cont.)				PLYMOUTH (cont.)			
COLT (cont.)				SCAMP			
4 CYL (cont.)				4 CYL			
1987-89	1.5L	4 Spd, KM200 Trans, CORE REQUIRED, REBUILD AND RETURN ONLY, Use 75W90	KM200	1983	2.2L	4 Spd, NP833 Trans (3 Spd w/OD), Iron Case Or Aluminum Case, 10 Bolt Side Cover, CORE REQUIRED, REBUILD AND RETURN ONLY, Use ATF	NP833O/D
1987-89	1.5L	5 Spd, KM201 Trans, CORE REQUIRED, REBUILD AND RETURN ONLY, Use 75W90	KM201	6 CYL			
1987-89	1.6L	5 Spd, KM206 Trans, CORE REQUIRED, REBUILD AND RETURN ONLY, Use 75W90	KM206				
COLT VISTA				8 CYL			
4 CYL							
1992-94	1.8L, 2.4L	5 Spd, F5M22 Trans, CORE REQUIRED, REBUILD AND RETURN ONLY, Use 75W90	F5M22	1975	3.7L	4 Spd, NP833 Trans, Iron Case Non Overdrive, 10 Bolt Side Cover, CORE REQUIRED, REBUILD AND RETURN ONLY, Use 80W90	NP833
DUSTER				8 CYL			
6 CYL							
1975-76	3.7L	4 Spd, NP833 Trans (3 Spd w/OD), Iron Case Or Aluminum Case, 10 Bolt Side Cover, CORE REQUIRED, REBUILD AND RETURN ONLY, Use ATF	NP833O/D	1975-76	5.2L	4 Spd, NP833 Trans (3 Spd w/OD), Iron Case Or Aluminum Case, 10 Bolt Side Cover, CORE REQUIRED, REBUILD AND RETURN ONLY, Use ATF	NP833O/D
1975	3.7L	4 Spd, NP833 Trans, Iron Case Non Overdrive, 10 Bolt Side Cover, CORE REQUIRED, REBUILD AND RETURN ONLY, Use 80W90	NP833	1975	5.2L	4 Spd, NP833 Trans, Iron Case Non Overdrive, 10 Bolt Side Cover, CORE REQUIRED, REBUILD AND RETURN ONLY, Use 80W90	NP833
8 CYL				TRAILDUSTER			
1975-76	5.2L, 5.9L	4 Spd, NP833 Trans (3 Spd w/OD), Iron Case Or Aluminum Case, 10 Bolt Side Cover, CORE REQUIRED, REBUILD AND RETURN ONLY, Use ATF	NP833O/D	6 CYL			
1975	5.2L, 5.9L	4 Spd, NP833 Trans, Iron Case Non Overdrive, 10 Bolt Side Cover, CORE REQUIRED, REBUILD AND RETURN ONLY, Use 80W90	NP833				
LASER				8 CYL			
4 CYL							
1990-94	1.8L	5 Spd, F5M22 Trans, CORE REQUIRED, REBUILD AND RETURN ONLY, Use 75W90	F5M22	1975-80	3.7L	4x2, 4 Spd, NP435 Trans, Aluminum Tail Housing, Use 50WT Fluid	NP435-G
NEON				1975-80	3.7L	4x2, 4 Spd, NP435 Trans, Cast Iron Tail Housing, Use 50WT Fluid	NP435-F
4 CYL				1975-80	3.7L	4x4, 4 Spd, NP435 Trans, Used With Divorced Transfer Cases, Use 50WT Fluid	NP435-J
1995-98	2.0L	5 Spd, All Aluminum Case, Cable Operated Clutch, Use MOPAR# 4874465 Fluid	A578-A	1975-80	3.7L	4x4, 4 Spd, NP435 Trans, Used With NP203 Or NP205 Transfer Case, Use 50WT Fluid	NP435-I
1995-98	2.0L	5 Spd, All Aluminum Case, Hydraulic Operated Clutch, Use MOPAR# 4874465 Fluid	A578-B	1975-80	3.7L	4x4, 4 Spd, NP435 Trans, Used With NP208 Transfer Case, Use 50WT Fluid	NP435-H
8 CYL				1975-81	5.2L, 5.9L, 6.6L, 7.2L	4x2, 4 Spd, NP435 Trans, Aluminum Tail Housing, Use 50WT Fluid	NP435-G
				1975-81	5.2L, 5.9L, 6.6L, 7.2L	4x2, 4 Spd, NP435 Trans, Cast Iron Tail Housing, Use 50WT Fluid	NP435-F
8 CYL				1975-81	5.2L, 5.9L, 6.6L, 7.2L	4x4, 4 Spd, NP435 Trans, Used With Divorced Transfer Cases, Use 50WT Fluid	NP435-J
				1975-81	5.2L, 5.9L, 6.6L, 7.2L	4x4, 4 Spd, NP435 Trans, Used With NP203 Or NP205 Transfer Case, Use 50WT Fluid	NP435-I
8 CYL				1975-81	5.2L, 5.9L, 6.6L, 7.2L	4x4, 4 Spd, NP435 Trans, Used With NP208 Transfer Case, Use 50WT Fluid	NP435-H
				1975-81	5.2L, 5.9L, 6.6L, 7.2L	4x4, 4 Spd, NP435 Trans, Used With NP208 Transfer Case, Use 50WT Fluid	NP435-H

Pro King Manual Transmissions

YEAR	ENGINE	APPLICATION	PART NO.	YEAR	ENGINE	APPLICATION	PART NO.
PLYMOUTH (cont.)				PONTIAC (cont.)			
VALIANT				FIERO (cont.)			
6 CYL				4 CYL (cont.)			
1975-76	3.7L	4 Spd, NP833 Trans (3 Spd w/OD), Iron Case Or Aluminum Case, 10 Bolt Side Cover, CORE REQUIRED, REBUILD AND RETURN ONLY, Use ATF	NP833O/D	1985-88	2.5L	5 Spd, MR8 Isuzu Style Trans, Aluminum Rear Cover Over 5th Gears, CORE REQUIRED, REBUILD AND RETURN ONLY, Use GM# 12345349 Fluid	MR8
1975	3.7L	4 Spd, NP833 Trans, Iron Case Non Overdrive, 10 Bolt Side Cover, CORE REQUIRED, REBUILD AND RETURN ONLY, Use 80W90	NP833	6 CYL			
8 CYL				1986-88	2.8L	5 Spd, MR10 Muncie Style Trans, Flat Metal Cover Over 5th Gears, CORE REQUIRED, REBUILD AND RETURN ONLY, Use GM# 12345349 Fluid	MR10
1975-76	5.2L, 5.9L	4 Spd, NP833 Trans (3 Spd w/OD), Iron Case Or Aluminum Case, 10 Bolt Side Cover, CORE REQUIRED, REBUILD AND RETURN ONLY, Use ATF	NP833O/D	1985-88	2.8L	5 Spd, MR8 Isuzu Style Trans, Aluminum Rear Cover Over 5th Gears, CORE REQUIRED, REBUILD AND RETURN ONLY, Use GM# 12345349 Fluid	MR8
1975	5.2L	4 Spd, NP833 Trans, Iron Case Non Overdrive, 10 Bolt Side Cover, CORE REQUIRED, REBUILD AND RETURN ONLY, Use 80W90	NP833	FIREBIRD			
VOLARE				4 CYL			
6 CYL				1982-85	2.5L	4 Spd, T10 Trans, 9 Bolt Side Cover, Super T10 Only, CORE REQUIRED, REBUILD AND RETURN ONLY, Use 80W90	T10W
1976-79	3.7L	4 Spd, NP833 Trans (3 Spd w/OD), Iron Case Or Aluminum Case, 10 Bolt Side Cover, CORE REQUIRED, REBUILD AND RETURN ONLY, Use ATF	NP833O/D	6 CYL			
8 CYL				1996-02	3.8L	5 Spd, T5 Trans, World Class, ATF Used	T5-CM
1976-79	5.2L, 5.9L	4 Spd, NP833 Trans (3 Spd w/OD), Iron Case Or Aluminum Case, 10 Bolt Side Cover, CORE REQUIRED, REBUILD AND RETURN ONLY, Use ATF	NP833O/D	1993-96	3.4L, 3.8L	6 Spd, T56 Trans, CORE REQUIRED, REBUILD AND RETURN ONLY, Use ATF	T56-A
PONTIAC				1993-95	3.4L, 3.8L	5 Spd, Borg Warner T5, Speedo- Beige, ATF Used	T5-CL
6000				1981-85	2.8L, 3.8L	4 Spd, T10 Trans, 9 Bolt Side Cover, Super T10 Only, CORE REQUIRED, REBUILD AND RETURN ONLY, Use 80W90	T10W
4 CYL				1975	4.1L	4 Spd, T10 Trans, 9 Bolt Side Cover, Super T10 Only, CORE REQUIRED, REBUILD AND RETURN ONLY, Use 80W90	T10W
1986-88	2.5L	5 Spd, MR10 Muncie Style Trans, Flat Metal Cover Over 5th Gears, CORE REQUIRED, REBUILD AND RETURN ONLY, Use GM# 12345349 Fluid	MR10	8 CYL			
6 CYL				1997-02	5.7L	6 Spd, T56 Trans, CORE REQUIRED, REBUILD AND RETURN ONLY, Use ATF	T56-B
1986-88	2.8L, 3.1L	5 Spd, MR10 Muncie Style Trans, Flat Metal Cover Over 5th Gears, CORE REQUIRED, REBUILD AND RETURN ONLY, Use GM# 12345349 Fluid	MR10	1993-96	5.7L	6 Spd, T56 Trans, CORE REQUIRED, REBUILD AND RETURN ONLY, Use ATF	T56-A
FIERO				1983-87	5.0L, 5.7L	5 Spd, Borg Warner T5, Speedo- Purple, ATF Used	T5-CC
4 CYL				1981-85	4.3L, 4.4L, 4.9L, 5.0L	4 Spd, T10 Trans, 9 Bolt Side Cover, Super T10 Only, CORE REQUIRED, REBUILD AND RETURN ONLY, Use 80W90	T10W
1986-88	2.5L	5 Spd, MR10 Muncie Style Trans, Flat Metal Cover Over 5th Gears, CORE REQUIRED, REBUILD AND RETURN ONLY, Use GM# 12345349 Fluid	MR10	1975	5.7L, 6.6L, 7.5L	4 Spd, T10 Trans, 9 Bolt Side Cover, Super T10 Only, CORE REQUIRED, REBUILD AND RETURN ONLY, Use 80W90	T10W

Pro King Manual Transmissions

YEAR	ENGINE	APPLICATION	PART NO.	YEAR	ENGINE	APPLICATION	PART NO.
PONTIAC (cont.)				PONTIAC (cont.)			
GRAND AM				LEMANS			
4 CYL				4 CYL			
1988-94	2.0L, 2.3L, 2.5L	5 Spd, MR10 Muncie Style Trans, Flat Metal Cover Over 5th Gears, CORE REQUIRED, REBUILD AND RETURN ONLY, Use GM# 12345349 Fluid	MR10	1988-93	1.6L, 2.0L	5 Spd, MR8 Isuzu Style Trans, Aluminum Rear Cover Over 5th Gears, CORE REQUIRED, REBUILD AND RETURN ONLY, Use GM# 12345349 Fluid	MR8
1985-98	2.0L, 2.3L, 2.4L, 2.5L	5 Spd, MR8 Isuzu Style Trans, Aluminum Rear Cover Over 5th Gears, CORE REQUIRED, REBUILD AND RETURN ONLY, Use GM# 12345349 Fluid	MR8	SUNBIRD			
6 CYL				4 CYL			
1992-98	3.1L, 3.3L	5 Spd, MR8 Isuzu Style Trans, Aluminum Rear Cover Over 5th Gears, CORE REQUIRED, REBUILD AND RETURN ONLY, Use GM# 12345349 Fluid	MR8	1991-94	2.0L	5 Spd, MR10 Muncie Style Trans, Flat Metal Cover Over 5th Gears, CORE REQUIRED, REBUILD AND RETURN ONLY, Use GM# 12345349 Fluid	MR10
1992-94	3.1L, 3.3L	5 Spd, MR10 Muncie Style Trans, Flat Metal Cover Over 5th Gears, CORE REQUIRED, REBUILD AND RETURN ONLY, Use GM# 12345349 Fluid	MR10	1986	1.8L, 2.0L	5 Spd, MR10 Muncie Style Trans, Flat Metal Cover Over 5th Gears, CORE REQUIRED, REBUILD AND RETURN ONLY, Use GM# 12345349 Fluid	MR10
1985-87	3.0L	5 Spd, MR8 Isuzu Style Trans, Aluminum Rear Cover Over 5th Gears, CORE REQUIRED, REBUILD AND RETURN ONLY, Use GM# 12345349 Fluid	MR8	1985-94	1.8L, 2.0L	5 Spd, MR8 Isuzu Style Trans, Aluminum Rear Cover Over 5th Gears, CORE REQUIRED, REBUILD AND RETURN ONLY, Use GM# 12345349 Fluid	MR8
8 CYL				6 CYL			
1975	5.7L, 6.6L, 7.5L	4 Spd, T10 Trans, 9 Bolt Side Cover, Super T10 Only, CORE REQUIRED, REBUILD AND RETURN ONLY, Use 80W90	T10W	1991-94	3.1L	5 Spd, MR10 Muncie Style Trans, Flat Metal Cover Over 5th Gears, CORE REQUIRED, REBUILD AND RETURN ONLY, Use GM# 12345349 Fluid	MR10
GRAND PRIX				SUNFIRE			
4 CYL				4 CYL			
1990	2.3L	5 Spd, MR10 Muncie Style Trans, Flat Metal Cover Over 5th Gears, CORE REQUIRED, REBUILD AND RETURN ONLY, Use GM# 12345349 Fluid	MR10	1995-02	2.2L, 2.3L, 2.4L	5 Spd, MR8 Isuzu Style Trans, Aluminum Rear Cover Over 5th Gears, CORE REQUIRED, REBUILD AND RETURN ONLY, Use GM# 12345349 Fluid	MR8
6 CYL				SUNFIRE			
1988-90	2.8L, 3.1L	5 Spd, MR10 Muncie Style Trans, Flat Metal Cover Over 5th Gears, CORE REQUIRED, REBUILD AND RETURN ONLY, Use GM# 12345349 Fluid	MR10	4 CYL			
J2000				SUNFIRE			
4 CYL				4 CYL			
1983-84	1.8L, 2.0L	5 Spd, MR8 Isuzu Style Trans, Aluminum Rear Cover Over 5th Gears, CORE REQUIRED, REBUILD AND RETURN ONLY, Use GM# 12345349 Fluid	MR8	SATURN			
J2000				"SC, SL, SW SERIES"			
4 CYL				4 CYL			
1983-84	1.8L, 2.0L	5 Spd, MR8 Isuzu Style Trans, Aluminum Rear Cover Over 5th Gears, CORE REQUIRED, REBUILD AND RETURN ONLY, Use GM# 12345349 Fluid	MR8	1993-00	1.9L	5 Spd, SAT1 Trans, Aluminum Case, Without Mounting Boss, 7 Bolt Cover Over 5th, REBUILDABLE CORE REQUIRED, REBUILD AND RETURN ONLY, Use ATF	SATURN-B

Pro King Manual Transmissions

YEAR	ENGINE	APPLICATION	PART NO.	YEAR	ENGINE	APPLICATION	PART NO.
SATURN (cont.)				TOYOTA (cont.)			
"SC, SL, SW SERIES" (cont.)				4RUNNER (cont.)			
4 CYL (cont.)				6 CYL (cont.)			
1991-92	1.9L	5 Spd, SAT1 Trans, Aluminum Case, With Mounting Boss, 7 Bolt Cover Over 5th, REBUILDABLE CORE REQUIRED, REBUILD AND RETURN ONLY, Use ATF	SATURN-A	1988-89	3.0L	4x4, 5 Spd, G52, No Speedo, Synthetic 75w90 Used	G52-A
TOYOTA				CAMRY			
4RUNNER				4 CYL			
4 CYL				6 CYL			
1998-00	2.7L	4x2, 5 Spd, R151 Trans, CORE REQUIRED, REBUILD AND RETURN ONLY	R150	1983-84	1.8L, 2.0L	5 Spd, S51 Trans, Use 75W90	S51
1998-00	2.7L	4x2, 5 Spd, W59 Trans, Use 75W90	W59-B	CELICA			
1998-00	2.7L	4x4, 5 Spd, W59 Trans, Use 75W90	W59-A	4 CYL			
1990-95	2.4L	4x2, 5 Spd, W55 Trans, Use 75W90	W55-C	1990-97	1.6L, 1.8L	5 Spd, C52 Trans, REBUILDABLE CORE REQUIRED, REBUILD AND RETURN ONLY, Use 75W90	C52
1989-95	2.4L	4x2, 5 Spd, R151 Trans, CORE REQUIRED, REBUILD AND RETURN ONLY	R150	1981-85	2.4L	5 Spd, W55 Trans, Shifter Hangs Over Rear Seal, Use 75W90	W55-A
1989-90	2.4L	4x4, 5 Spd, G58 Trans, With Chain Drive Transfer Case, CORE REQUIRED, REBUILD AND RETURN ONLY	G58	1981-85	2.4L	5 Spd, W55 Trans, Shifter Is Midway On Tail Housing, Use 75W90	W55-B
1988-95	2.4L	4x4, 5 Spd, W56, No Speedo, Fuel Injected, 2 Shifter Sticks In Shifter Tower, 1 Transmission, 1 Transfer case, Use 75W90	W56-B	COROLLA			
1985-89	2.4L	4x2, 5 Spd, G52, W/Speedo, Synthetic 75w90 Used	G52-B	4 CYL			
1984-89	2.4L	4x4, 5 Spd, G52, No Speedo, Synthetic 75w90 Used	G52-A	1988-92	1.6L	5 Spd, E57 Trans, CORE REQUIRED, REBUILD AND RETURN ONLY, Use 75W90	E57
1984-87	2.4L	4x4, 5 Spd, W56, No Speedo, Fuel Injected, 1 Shifter Stick In Shifter Tower, Use 75W90	W56-A	1984-88	1.6L, 1.8L	5 Spd, C51 Trans, CORE REQUIRED, REBUILD AND RETURN ONLY, Use SYNTHETIC 75W90	C51
1984	2.4L	4x2, 5 Spd, G52, W/Speedo, Synthetic 75w90 Used, Carbureted	G52-B	MR2			
6 CYL				4 CYL			
1990-95	3.0L	4x2, 5 Spd, W55 Trans, Use 75W90	W55-C	1985-89	1.6L	5 Spd, C52 Trans, REBUILDABLE CORE REQUIRED, REBUILD AND RETURN ONLY, Use 75W90	C52
1989-95	3.0L	4x4, 5 Spd, R151 Trans, Use 75W90	R151-A	PASEO			
1989-90	3.0L	4x4, 5 Spd, G58 Trans, With Chain Drive Transfer Case, CORE REQUIRED, REBUILD AND RETURN ONLY	G58	4 CYL			
1989-01	3.0L, 3.4L	4x2, 5 Spd, R151 Trans, CORE REQUIRED, REBUILD AND RETURN ONLY	R150	1992-98	1.5L	5 Spd, Aluminum Case With Black Tin Cover, Use 75W90	C150
1988-95	3.0L	4x4, 5 Spd, W56, No Speedo, Fuel Injected, 2 Shifter Sticks In Shifter Tower, 1 Transmission, 1 Transfer case, Use 75W90	W56-B	PICKUP			
1988-89	3.0L	4x2, 5 Spd, G52, W/Speedo, Synthetic 75w90 Used	G52-B	4 CYL			
				1989-95	2.4L	4x2, 4 Spd, W46 Trans, Use 75W90	W46
				1989-95	2.4L	4x2, 5 Spd, W55 Trans, Use 75W90	W55-C
				1988-95	2.4L	4x4, 5 Spd, W56, No Speedo, Fuel Injected, 2 Shifter Sticks In Shifter Tower, 1 Transmission, 1 Transfer case, Use 75W90	W56-B
				1985-95	2.4L	4x2, 5 Spd, R151 Trans, CORE REQUIRED, REBUILD AND RETURN ONLY	R150
				1984-95	2.4L	4x2, 4 Spd, G40 Trans, Aluminum Case, Bell And Tail Housing, Use 75W90	G40

Pro King Manual Transmissions

YEAR	ENGINE	APPLICATION	PART NO.	YEAR	ENGINE	APPLICATION	PART NO.
TOYOTA (cont.)				TOYOTA (cont.)			
PICKUP (cont.)				TACOMA			
4 CYL (cont.)				4 CYL			
1984-88	2.4L	4x2, 5 Spd, W55 Trans, Shifter Is Midway On Tail Housing, Use 75W90	W55-B	1995-03	2.4L, 2.7L	4x2, 5 Spd, R151 Trans, CORE REQUIRED, REBUILD AND RETURN ONLY	R150
1984-87	2.4L	4x4, 5 Spd, W56, No Speedo, Fuel Injected, 1 Shifter Stick In Shifter Tower, Use 75W90	W56-A	1995-03	2.4L, 2.7L	4x2, 5 Spd, W59 Trans, Use 75W90	W59-B
6 CYL				6 CYL			
1989-95	3.0L	4x2, 4 Spd, W46 Trans, Use 75W90	W46	1995-03	3.4L	4x2, 5 Spd, R151 Trans, CORE REQUIRED, REBUILD AND RETURN ONLY	R150
1989-95	3.0L	4x2, 5 Spd, W55 Trans, Use 75W90	W55-C	1995-03	3.4L	4x4, 5 Spd, R151 Trans, CORE REQUIRED, REBUILD AND RETURN ONLY, Use 75W90	R151-B
1989-94	3.0L	4x4, 5 Spd, R151 Trans, Use 75W90	R151-A				
1988-95	3.0L	4x2, 4 Spd, G40 Trans, Aluminum Case, Bell And Tail Housing, Use 75W90	G40				
1988-95	3.0L	4x2, 5 Spd, R151 Trans, CORE REQUIRED, REBUILD AND RETURN ONLY	R150				
1988	3.0L	4x2, 5 Spd, W55 Trans, Shifter Is Midway On Tail Housing, Use 75W90	W55-B				
RAV4				TERCEL			
4 CYL				4 CYL			
1996-03	2.0L	4x2, 5 Spd, E250 Trans, REBUILDABLE CORE REQUIRED, REBUILD AND RETURN ONLY, Use 75W90	E250-A	1988-98	1.5L	5 Spd, Aluminum Case With Black Tin Cover, Use 75W90	C150
1996-03	2.0L	4x4, 5Spd, E250 Trans, REBUILDABLE CORE REQUIRED, REBUILD AND RETURN ONLY, Use 75W90	E250-B	1988-96	1.5L	4 Spd, C140 Trans, Aluminum Case With Black Tin Cover, Use 75W90	C140
T100				TUNDRA			
4 CYL				6 CYL			
1998	2.7L	4x2, 5 Spd, R151 Trans, CORE REQUIRED, REBUILD AND RETURN ONLY	R150	2000-04	3.4L	4x2, 5 Spd, R151 Trans, CORE REQUIRED, REBUILD AND RETURN ONLY	R150
1995-97	2.7L	4x2, 5 Spd, W59 Trans, Use 75W90	W59-B				
1995-97	2.7L	4x4, 5 Spd, W56, No Speedo, Fuel Injected, 2 Shifter Sticks In Shifter Tower, 1 Transmission, 1 Transfer case, Use 75W90	W56-B				
1995-97	2.7L	4x4, 5 Spd, W59 Trans, Use 75W90	W59-A				
1994	2.7L	4x2, 5 Spd, R151 Trans, CORE REQUIRED, REBUILD AND RETURN ONLY	R150				
6 CYL							
1995-98	3.4L	4x4, 5 Spd, R151 Trans, Use 75W90	R151-D				
1995	3.4L	4x4, 5 Spd, W56, No Speedo, Fuel Injected, 2 Shifter Sticks In Shifter Tower, 1 Transmission, 1 Transfer case, Use 75W90	W56-B				
1993-98	3.0L, 3.4L	4x2, 5 Spd, R151 Trans, CORE REQUIRED, REBUILD AND RETURN ONLY	R150				
1993-94	3.0L	4x4, 5 Spd, R151 Trans, Use 75W90	R151-A				

PRO-KING ALSO FEATURES THESE OTHER PRODUCTS



Differential Components



Ring & Pinions



Standard Components



Torque Converters

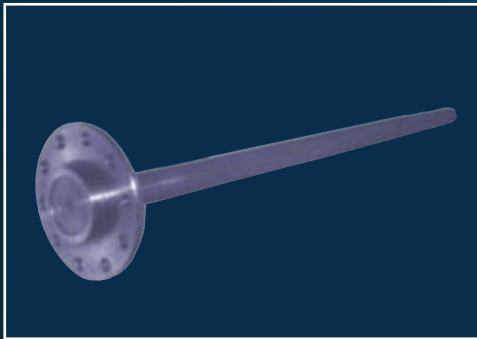

Axle Shafts & Axle Shaft Kits



Transfer Case Units & Parts

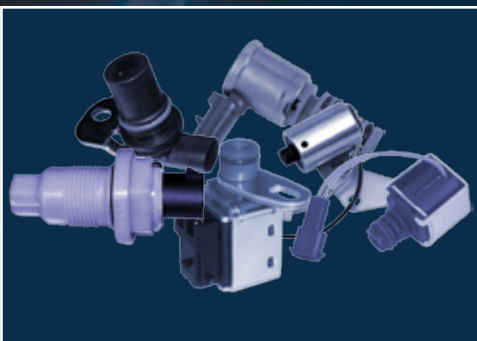

**Electrical Components
(for Transfer Case Units, Automatic
Transmissions) (Solenoids)**



MEMPHIS
3543 Lamar Avenue
Memphis, TN 38118

Shipping & Billing
T 901.368.0799
F 901.541.6599

Technical Application Support
1.800.921.1956, Ext 130

KING-O-MATIC INDUSTRIES IS A DIVISION OF TRANSTAR INDUSTRIES INC.

